



# SPECIAL TOOLS FOR AUTO REPAIRS

INVEST IN TIME





**Company profile:**

Wallmek i Kungälv AB was started in 1978, producing and designing special tools for car repairs. Wallmek stands for idea and design of tools, up to delivery of a complete product to the customer. Our products are in the segments of chassis tools and liquid handling equipment.

The Wallmek research and development department works in close cooperation with automotive workshops to ensure the best possible productivity, ergonomics and health. We are very good at designing hydraulic tools that enable repairs directly on the car, handling of fuel when tank repairs are necessary and to make drainage systems for car dismantlers. Today Wallmek is developing tools directly for car manufacturers, after market and garages. For the car dismantling industry, we develop tools for draining all liquids from the cars to make them environmentally decontaminated.

As the company continues to expand, we are now also involved in customer segments like trucks, trailers and constructions machinery. In short terms – we develop Wallmek in a direction where our products make the best use for our customer.

**Our mission:**

To develop, produce and market our cost effective tools to our customers.

**Important for us:**

Quality! – To exceed the customers expectations.

Design! – Ergonomic, well thought out and functional products.

Customer care! – Being present and always available for support.

Welcome to Wallmek i Kungälv AB

Niklas Wallman  
Managing Director



## Hydraulic cylinders

### 1090-01 Hydraulic cylinder 16 ton (1090-01-WAL)

16 tons pressing and pulling hydraulic cylinder in a compact size. Designed for everyday use in auto repair shops.



Can be used with all of our passenger car tools and carriage beams M10-M22 with the proper adaptor. The cylinder's hydraulic pressure can be combined with punching force when using the punching socket 1086-6 (only 1090-01-WAL). For example when pressing a rusted axle shaft. Weight: 3,4 kg. Stroke: 67 mm.

#### Parts in the set:

1. 1-1090-01 - Hydraulic cylinder 16 ton
2. RES 1090-01-08 - Press axle 129,5mm, M24x3
3. RES 1090-01-09 - Press plate M24x3
4. RES 1090-01-10 - Adjustable press rod 92mm, M24
5. RES 1090-01-13 - Lid with o-ring
6. RES4024 - Flange nut M18
7. RES4026 - Carriage beam M18/M22, 250mm
8. RES4306 - Hydraulic quick coupling, male

#### Included in 1090-01-WAL

9. 1086-6 - Punching socket M22x2,5
10. RES 1090-01-12 - Adjustable press rod 132mm, M24

### 1090-02-WAL Hydraulic cylinder 22 ton

22 tons pressing and pulling hydraulic cylinder in a compact size with automatic return of piston. Designed for everyday use in auto repair shops.



Can be used with all of our passenger car tools and carriage beams M10-M22 with the proper adaptor. The cylinder's hydraulic pressure can be combined with punching force when using the punching socket 1086-6. For example when pressing a rusted axle shaft. Weight: 4,7 kg. Stroke: 70 mm. **Automatic return.**

#### Parts in the set:

1. 1-1090-02 - Hydraulic cylinder 22 ton
2. 1086-6 - Punching socket M22x2,5
3. RES 1090-01-09 - Press plate M24x3
4. RES 1090-01-10 - Adjustable press rod 92mm, M24
5. RES 1090-01-13 - Lid for back end with O-ring
6. RES 1090-02-04 - Press axle 151mm, M24x3
7. RES 1090-05-02 - Adjustable press rod 109mm, M24
8. RES4024 - Flange nut M18
9. RES4026 - Carriage beam M18/M22, 250mm
10. RES4306 - Hydraulic quick coupling, male



### 1090-03 Hydraulic cylinder 14 ton

14 tons pressing hydraulic cylinder in a very compact size. Designed for everyday use in auto repair shops. Specially designed to use with press blocks 1090-55-B, 1090-60, 1090-69 and 03-00005-01. Weight: 2,5 kg. Stroke: 55 mm.

**Automatic return.**

**NEW!**

#### Parts in the set:

1. 1-1090-03 - Hydraulic cylinder 14 ton
2. RES 1090-01-10 - Adjustable press rod 92mm, M24
3. RES4306 - Hydraulic quick coupling, male



### 03-00015 Hydraulic cylinder 8,5 ton

A very compact cylinder for pressing and pulling. The cylinder comes with an adjustable press rod and a punching socket. This cylinder is very flexible and easy to use also in narrow areas. Specially designed to be used with 03-00014-001 and 03-00005-001. Weight: 1,8 kg. Stroke: 25 mm. **Automatic return.**

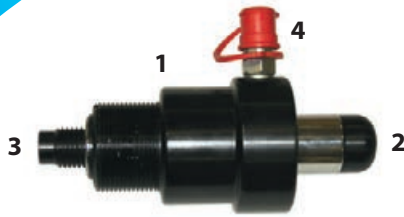

**Parts in the set:**

1. 03-00015-001 - Hydraulcylinder 8,5 ton
2. 03-00015-006 - Punching socket with o-ring
3. 03-00015-012 - Adjustable press rod 100mm, M22
4. RES4305 - Hydraulic quick coupling, male, 1/8"

### 03-00028 Hydraulic cylinder 32 ton

32 tons pressing and pulling hydraulic cylinder. Designed for everyday use in auto repair shops. Primarily for use with our wheel bearing tools for light commercial vehicles and trucks. Can be used with carriage beams M10-M22 with the proper adaptor. The cylinder's hydraulic pressure can be combined with punching force when using punching socket 1086-6 or punching nut 1091-17-M22. Weight: 8,3 kg. Stroke: 113 mm. **Automatic return.**



**Parts in the set:**

1. 03-00028-001 - Hydraulcylinder 32 ton
2. RES 1090-05-02 - Adjustable press rod 109mm, M24
3. RES 1090-05-04 - Thread protection ring (2,5")
4. RES4025 - Flange nut M22
5. RES4027 - Carriage beam M22, 250mm
6. 1091-17 - Punching nut M22
7. 1086-6 - Punching socket M22
8. RES4306 - Hydraulic quick coupling, male

### 03-00026 Hydraulic cylinder 45 ton

45 ton pressing and pulling cylinder. Designed for everyday use in auto repair shops. Primarily for use with our hub dismantling tools 03-00016, 03-00022 and 03-00027. The hydraulic cylinder's pressure can be combined with punching force when using punching socket 03-00026-006. Weight: 11,7 kg. Stroke: 70 mm. **Automatic return.**

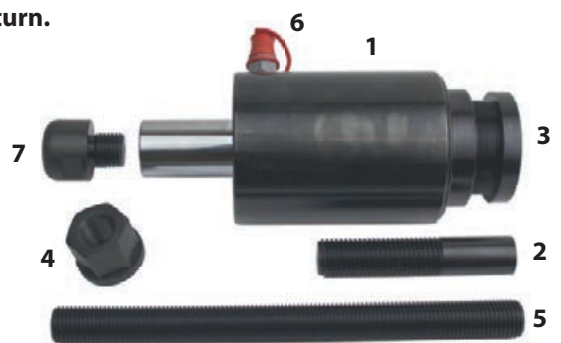

**Parts in the set:**

1. 03-00026-001 - Hydraulic cylinder 45 ton
2. 03-00026-012 - Adjustable press rod M30.145 mm
3. RES1090-05-04 - Thread protection ring (2,5")
4. RES4035 - Flange nut M27
5. RES4036 - Carriage beam M27. 330 mm
6. RES4306 - Hydraulic quick coupling, male
7. 03-00026-006 - Punching socket M27

### 01-00020 Carriage beam set manual wheel bearing replacement

Carriage beam set for manual use of wheel bearing tools. The set is used by hand or with an impact air gun. It's designed for the following tool sets: 1090-20, 1090-25, 1090-26, 1090-27, 01-00018, 01-00026, 01-00027 and 01-00019. For more frequent work we recommend using our hydraulic cylinders instead.



**Parts in the set:**

1. 01-00020-001 - Carriage beam M18, 330mm with nut
2. 01-00020-002 - Plate 19x45x5
3. 01-00020-003 - Press plate
4. RES4024 - Flange nut M18

**NEW!**



### 01-00031 Punching nut M18

When punching force is needed for pulling with our hydraulic cylinders. Useful for hubs and wheel bearing removal. Also used with the manual carriage beam 01-00020.



### 04-00015 Safety cover with catch strap

Additional item for hydraulic operation directly on the car. Prevents damage if parts brakes or falls down.



### Adaptors for other tool systems

1. **1068-02** Adaptor 1 1/2" to 2 1/4" – 16UN (Sauer, Muller etc thread)
2. **1068-04** Adaptor 1 1/2" to 2 1/4" – 14UNS (Klann thread)
3. **1068-05** Adaptor 1 1/2" to G2 1/2" – 11 (16 and 22 ton cylinder - 32 tons cylinder thread)
4. **1068-06** Adaptor 2 1/4" – 14UNS (Klann thread) to 1 1/2"
5. **1068-07** Adapter 1 1/2" to M55x1,5 (Volvo thread)
6. **1068-08** Adaptor 1 1/2" to M68x2 (Paschke thread)
7. **1068-09** Adaptor M68x2 (Paschke thread) to 1 1/2"

### 1090-32 Carriage beam, flange nut & adaptor set

Set of carriage beams, flange nuts and adaptors.

#### Parts in the set:



**RES4014**  
Carriage beam M10, 150 mm in 12.9 quality.



**RES4015**  
Carriage beam M12, 250 mm in 12.9 quality.



**RES4016**  
Carriage beam M14, 250 mm in 12.9 quality.



**RES4026**  
Carriage beam M18/M22, 250mm in 12.9 quality.



**RES4027**  
Carriage beam M22, 250mm in 12.9 quality.



**RES4012**  
Adaptor M22 → M10



**RES4023**  
Flange nut M10



**RES4011**  
Adaptor M22 → M12



**RES4022**  
Flange nut M12



**RES4010**  
Adaptor M22 → M14



**RES4021**  
Flange nut M14



**RES4024**  
Flange nut M18



**RES4025**  
Flange nut M22

### 04-00008-001 Carriage beam M10, 1000 mm

Produced in 12:9 quality, can also be ordered in 1/2 (delivered then in 500 mm length)

### 04-00008-003 Carriage beam M14, 1000 mm

Produced in 12:9 quality, can also be ordered in 1/2 (delivered then in 500 mm length)

### 04-00008-002 Carriage beam M12, 1000 mm

Produced in 12:9 quality, can also be ordered in 1/2 (delivered then in 500 mm length)

### 04-00008-004 Carriage beam M22, 1000 mm

Produced in 12:9 quality, can also be ordered in 1/2 (delivered then in 500 mm length)



### 1030 Hydraulic foot pump

Hydraulic foot pump 700 bar for use with all of our hydraulic cylinders. 2,2 m hose and drip-free quick coupling. Oil tank volume 0,75 litres.

**Parts in the set:**

1. 1-1030 - Hydraulic foot pump
2. RES 1030-02 - Hydraulic hose for 1030 & 1035
3. RES4304 - Hydraulic quick coupling, female



### 04-00020 Hydraulic oil 1 L

High quality hydraulic oil, optimal for Wallmek's hydraulic tools and pumps. Regular hydraulic oil change and correct volume increases the operation time of the components.



### 1-1035-02 Pneumatic hose kit with air pressure gun

Hose kit for fitting on 1035 to get an air pressure gun on the hydraulic hose for returning of hydraulic cylinders 1090-01, 1090-01-WAL and 1090-05/03-00028.



### 1035 Pneumatic hydraulic pump

Pneumatic driven hydraulic pump 700 bar for use with all of our hydraulic cylinders. 2,2 m hose and drip-free quick coupling. Oil tank volume 1,4 litres.

**Parts in the set:**

1. 1-1035 - Pneumatic hydraulic pump
2. RES 1030-02 - Hydraulic hose for 1030 & 1035
3. RES4304 - Hydraulic quick coupling, female



### 1036 Pneumatic, variable hydraulic pump

Pneumatic driven hydraulic pump with variable speed for better control. Max pressure 700 bar for use with all of our hydraulic cylinders. The pump is delivered with a pressure gauge next to the pedal and 2,2 m hose and drip-free quick coupling. Oil tank volume 1,3 litres.

**Parts in the set:**

1. 1-1036 - Pneumatic, variable hydraulic pump
2. RES 1030-02 - Hydraulic hose for 1030, 1035 & 1036
3. RES4304 - Hydraulic quick coupling, female



### 04-00016 Pressure gauge set for hydraulic pumps 1030 and 1035

A complete kit with coupling and nipple for connection directly to any Wallmek hydraulic pumps. The hydraulic cylinders manual includes a chart that shows the maximum oil pressure in bars for each different carriage beam.

## 04-00021 Cylinder holder Ø65-100 mm

Developed for use with the following cylinders; 1090-01, 1090-02, 1090-03 and 1090-05/03-00028.

The holder is designed for use on the cylinders with hand held use and for use on a floor stand or gear box lift. Adjusting and locking of the cylinder is very easy and flexible for simple use.

Also other cylinder brands and types from Ø65 – 100 mm can be mounted in the holder.

Fit's gearbox lift and floor stand with axle measure from 25/30 mm.



### Use with cylinder:

1090-01 (16 T)  
1090-02 (22 T)  
1090-03 (14 T)  
03-00028 (32 T)  
1090-05 (32 T)

### Parts in the set:

04-00021-001 - Holder without clamps  
04-00021-013 - Clamp Ø70 mm  
04-00021-014 - Clamp Ø85 mm  
04-00021-015 - Clamp Ø100 mm



Hand held



Gearbox lift and floor stand

# Bearing, axle shaft & hub sets

See each set for recommended cylinder.

## 1090-25 Compact wheel bearing mounting tool

Universal tool for **mounting** the new type of compact wheel bearings, with or without locking ring. It's adjustable to fit future bearing sizes and all current VW Lupo, Polo Transporter 5, Touareg, Audi A2, Seat Cordoba and Skoda Fabia. Volvo V50/S40, V70/ S80 and XC60. Ford Focus, C max, Mondeo, S-Max and Kuga. Mazda 3, 5, 6, and CX-7. Landrover Freelander 2. Mercedes Vito and Sprinter. Mitsubishi Colt and Smart Forfour with this type of bearing. Rec. cylinder 1090-01/1090-02-WAL.



### Parts in the set:

1. 1090-25-01 - Fixing plate
2. 4 pcs 1090-25-02 - Press foot
3. 4 pcs 1090-25-03 - Bolt M14



### 1090-25-11 Holding plate

For mounting compact wheel bearings on VW Lupo, Polo 9N and equivalent models on Audi, Seat and Skoda with 1090-25. Mitsubishi Colt och Smart Forfour. Inner Ø 21 mm.



### 1090-25-12 Holding plate

For mounting compact wheel bearings on VW T5 and diesel Touareg models with 1090-25. Inner Ø 20,25 mm.



### 1090-25-13 Mounting ring

For mounting compact wheel bearings on Ford Mondeo, Mazda 6 and Volvo V70 2007- with 1090-25.



### 1090-25-14 Holding plate

For mounting compact wheel bearings on Ford Mondeo, Mazda 6 and Volvo V70 2007-, Ford Focus, Mazda 3 and Volvo S40/V50 2004- also Ford Focus C-max. S-Max, Kuga, Mazda 5 and CX-7, Freelander 2 with 1090-25. Inner Ø 20,25 mm.

## 01-00018 Compact wheel bearing dismounting tool

Universal tool for **dismounting** the new type of compact wheel bearings, with or without locking ring. Max pressure 22 ton. It's adjustable to fit future bearing sizes and all current VW Lupo, Polo Transporter 5, Touareg, Audi A2, Seat Cordoba och Skoda Fabia. Volvo V50/S40, V70/ S80 and XC60. Ford Focus, C max, Mondeo, S-Max and Kuga. Mazda 3, 5, 6, and CX-7. Landrover Freelander 2. Mercedes Vito and Sprinter. Mitsubishi Colt and Smart Forfour with this type of bearing. This tool can also be used as a hub puller on most other cars, also BMW. Rec. cylinder 1090-01/1090-02-WAL.

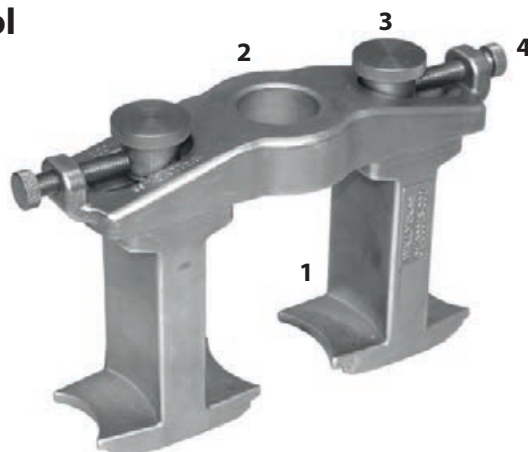

Press foot set 01-00018-020



### 1090-25-10 Coned dismounting plate (universal)

Plate for dismounting compact wheel bearings. Fits all sizes. Inner Ø 21 mm.

### Parts in the set

1. 2 x 01-00018-002 - Press foot
2. 01-00018-001 - Fixing plate
3. 2 x 01-00018-003 - Knob screw set
4. 2 x 01-00018-004 - Screw



**NEW!**

## 01-00026 Dismounting tool Bolted (4 bolts) wheel bearing/hub

The tool is adjustable and designed to dismantle bolted wheel bearings with guides that usually rust in the wheel spindles. Extraction can be done with a full 22 ton directly on the vehicle, while the hub can also be dismantled in instances where this will be reused in the new bearing.

Both press feet have two different sides, which are selected according to the vehicle/bearing design, adjustment is very easy. Designed and tested on the majority of 4 bolted wheel bearings.

Front and rear on: VW, Audi, Seat, Skoda, Volvo, Ford, Mazda, Toyota, Mitsubishi, etc.

Press foot 01-00026-001 used in pairs (01-00026-020) and can be ordered separately for use in tool 01-00018 (dismounting tool compact wheel bearing).

(Used with 1090-20-02, 04, 08 and T10.)

### Parts in the set:

1. 2 x 01-00026-001 - Press foot
2. 01-00018-001 - Fixing plate
3. 2 x 01-00018-003 - Knob screw set
4. 2 x 01-00018-004 - Screw



Press foot set 01-00026-020



## 01-00027 Dismounting tool Bolted (3 bolts) wheel bearing/hub Opel Insignia, Astra, Vectra, Saab 9 5

**NEW!**

The tool is adjustable and designed to dismantle bolted wheel bearings with guides that usually rust in the wheel spindles. Extraction can be done with a full 22 ton directly on the vehicle, while the hub can also be dismantled in instances where this will be reused in the new bearing.

Both press feet have two different sides, which are selected according to the vehicle/bearing design, adjustment is very easy. Designed and tested on the majority of 3 bolted wheel bearings, front and rear.

Press foot 01-00027-001 is used in pairs (01-00027-020) and can also be ordered separately for use in 01-00018 (dismounting tool for compact wheel bearings).

(Used with 1090-20-02, 04, 08 and T10.)

### Parts in the set:

1. 2 st 01-00027-001 - Press foot
2. 01-00018-001 - Fixing plate
3. 2 st 01-00018-003 - Knob screw set
4. 2 st 01-00018-004 - Screw



Press foot set 01-00027-020

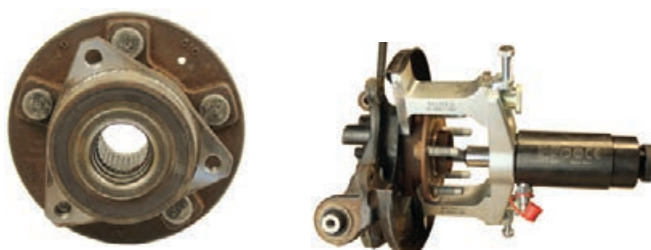

## 1090-20 Bearing, axle shaft & hub set

Universal front wheel bearing set with combined hub/axle shaft press clamp. The wheel bearing is replaced directly on the car with minimum work. Neither ABS-sensor, wheel spindle, spring strut or steering linkage needs to be

dismounted. There is also no need for toe-in adjustment or bleeding the brake system.

Est.time: 20-30 min/side.

Rec. cylinder 1090-01/1090-02-WAL.

### Parts in the set:

1. 1090-22 - Press clamp, axle shaft & hub
2. 1090-20-R4 - Bearing cup
3. 1090-20-BX - Press plate for 1090-20-R4
4. 1090-20-F1 - Adaptor for 1090-20-R4
5. 1090-20-R1 - Press pipe
6. 1090-20-M - Holder\*
7. 1090-20-02 - Hub plate 32mm\*
8. 1090-20-04 - Hub plate 40mm\*
9. 1090-20-06 - Hub plate 45mm\*
10. 1090-20-08 - Hub plate 52mm\*
11. 91090-20-T10 - Bearing plate 63mm\*
12. 1090-20-T12 - Bearing plate 68mm\*
13. 1090-20-T14 - Bearing plate 70,9mm\*
14. 1090-20-T15 - Bearing plate 73,9mm\*
15. 1090-20-T16 - Bearing plate 77,8mm\*
16. 1090-20-T18 - Bearing plate 82,9mm\*

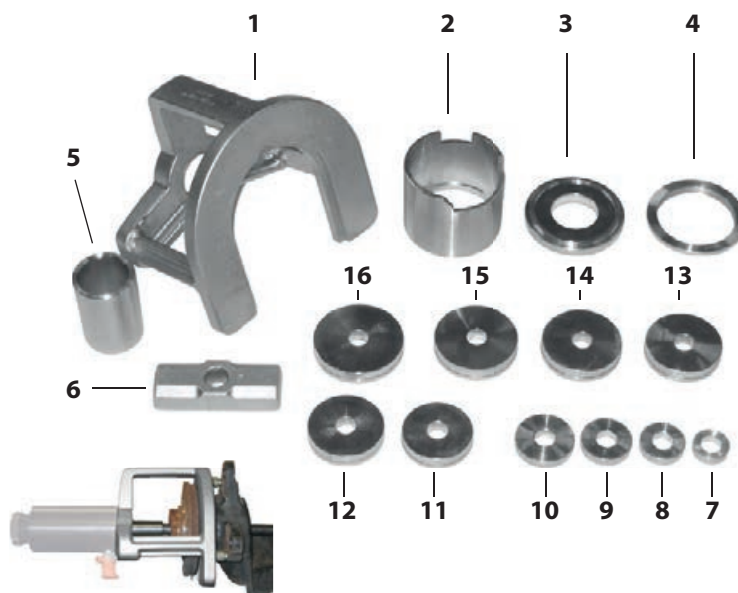

\*Inner Ø 20,25 mm

## 1090-26 Large bearing & hub cup

For dismounting of wheel bearings & hubs. This cup can be used on models that the standard press clamp (1090-22) don't fit on.

For example Volvo S40/V50, Ford C-Max & Mazda 3.

Also some models from Citroen, Peugeot, Renault & VAG.

Rec. cylinder 1090-01/1090-02-WAL.

### Parts in the set:

1. 1090-26-01 - Large press plate, two sided.
2. 1090-26-02 - Large press pipe, two sided.

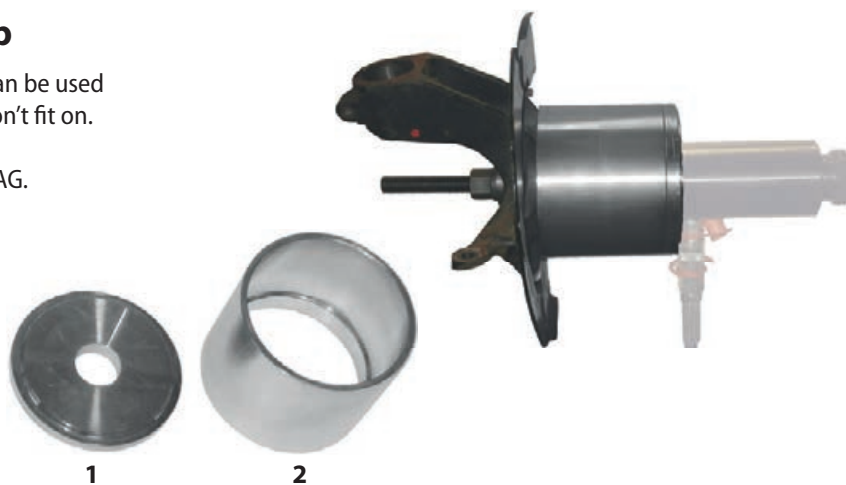

## 1090-27 Adjustable bearing fixture

The fixture is used when dismounting wheel bearings that are pulled inwards on for example Citroen, Peugeot and Renault. The problem with this type of wheel spindles is that the inside surface often is uneven. This tool has 3 screws and 6 holes for adjusting the plate to get a level pressing surface. It is used directly on the car with our hydraulic tools or in a workshop press. Rec. cylinder 1090-01/1090-02-WAL.

### Parts in the set:

1. 3 pcs 1090-27-01 - Screw
2. 1090-27-02 - Plate



## 01-00019 Wheel bearing and hub set front/rear Audi Q7/VW Touareg/Porsche Cayenne

The wheel bearing is replaced directly on the car without unnecessary dismounting. The entire job only takes about 30 minutes with this set. The parts are designed to protect the ABS-sensor and other sensitive parts.

Rec. cylinder 1090-01/1090-02-WAL/1090-05/03-00028.

### Parts in the set:

1. 01-00019-001 - Holding pipe
2. 01-00019-002 - Holding ring
3. 1090-20-R1 - Press pipe
4. 1090-20-T21 - Bearing plate Ø92\*
5. 1090-20-T22 - Bearing plate Ø95\*
6. 1091-10-04 - Hub plate\*
7. 1091-17-02 - Press plate\*
8. 1091-17-04 - Bearing plate\*
9. 2 pcs 1091-18-03 - Bolt M14x40

\*Inner Ø 23 mm



## 1090-30 Axle shaft tool 4 & 5 holes

This tool is specially developed for pressing out rusted & glued axle shafts directly on the car. This job only takes 5 min. The holes for the wheel bolts are oval to fit on almost all passenger cars with 4 & 5 holed hubs. With this equipment you avoid heating, splitting of the axle shaft or damage to other parts. Bolt on to the hub using the cars own wheel bolts, attach the cylinder, start pressing and for extra power fit a punching socket 1086-6 and then hammer on it. The tool can also be used for pulling wheel hubs with striking tool 1064 and adapter 1068. Rec. cylinder 1090-01/1090-02-WAL.

**Bolt dia 4 hole – 92-120 mm / 5 hole – 98-131 mm.**



**NEW!**

### Parts in the set:

1. 1090-30-4 - Axle shaft tool, 4 holes
2. 1090-30-5 - Axle shaft tool, 5 holes



## 1068 Adaptor from 1064 to 1090-30

Adaptor for using the striking tool 1064 with axle shaft tool 1090-30 for removal of wheel hubs.



## 1066 Hub set for 1064, dismounting

Set for hub dismounting with striking tool 1064.

### Parts in the set:

1. 1090-20-02 - Hub plate 32mm\*
2. 1090-20-04 - Hub plate 40mm\*
3. 1090-20-06 - Hub plate 45mm\*
4. 1090-20-08 - Hub plate 52mm\*
5. RES4024 - Flange nut M18
6. RES4030 - Carriage beam M18, 150mm

\*Inner Ø 20,25 mm

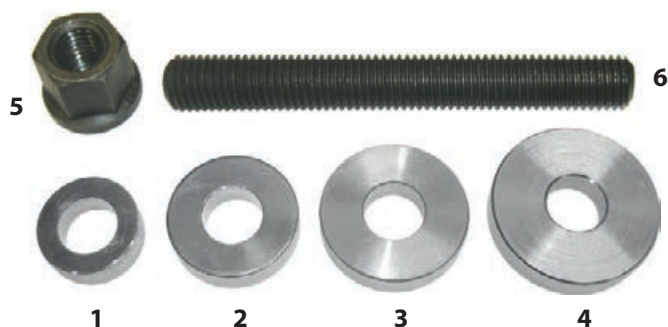

## 1064 Striking tool 5,2kg

Ergonomic slide hammer with 5,2 kg weight. Easy to get that extra force because of the side mounted handle. Very useful for dismounting the hub and brake disc at the same time. For use with hub set 1066 or adaptor 1068 for our axle shaft tool 1090-30.



## 01-00024 Mounting set for BMW drive shafts, hydraulic

The drive shaft is easily mounted using an 8.5 ton hydraulic cylinder that draws the shaft into the right position.

Adapters of high-strength steel for the shafts with M24x1.5 and M27x1.5 threads are included in the set, these are also available as accessories.

### Parts in the set:

1. 01-00024-001 Adapter for M24x1.5
2. 01-00024-002 Adapter for M27x1.5
3. RES4027 Carriage beam M22, 250 mm
4. 01-00001-203 Press pipe 44.7 mm
5. 03-00015 Hydraulic cylinder 8.5 ton



## 01-00024-010 Mounting set for BMW drive shafts, manual

The drive shaft is mounted manually using an M22 carriage beam and nut that draws the shaft into the right position. Adapters of high-strength steel for the shafts with M24x1.5 and M27x1.5 threads are included in the set, these are also available as accessories.

### Parts in the set:

1. 01-00024-001 Adapter for M24x1.5
2. 01-00024-002 Adapter for M27x1.5
3. RES4027 Carriage beam M22, 250 mm
4. 01-00001-203 Press pipe 44.7 mm
5. 01-00024-005 Thrust washer
6. RES4025 Flange nut M22



# Wheel bearing sets for light commercial vehicles

See each set for recommended cylinder.

## 1091-15 Wheel bearing set, rear for Citroën Jumper, Fiat Ducato & Peugeot Boxer

Set for replacing rear wheel bearings. The wheel bearing is replaced directly on the car with minimum dismounting. The bearings and hubs on these chassis often need the power of 32 ton combined with punching force to separate. Also the Axle shaft press is designed to fit all 5 holed hubs on commercial vehicles. Est.time: 40 min/side. Rec. cylinder 1090-05/03-00028.

### Parts in the set:

1. 1086-6 - Punching socket M22
2. 1090-15-B - Press socket
3. 1091-15-01 - Adaptor ring
4. 1091-17-04 - Bearing plate\*
5. 1091-17-07 - Hub plate\*
6. 1091-28 - Axle shaft tool, 5 holes, lkw



\*Inner Ø 23 mm

## 1091-17 Wheel bearing set, front for Citroën Jumper, Fiat Ducato & Peugeot Boxer

The wheel bearing is replaced directly on the car with minimum dismounting. The bearings and hubs on these chassis often need the power of 32 ton combined with punching force to separate. Est.time: 30-40 min/side. Rec. cylinder 1090-05/03-00028.

### Parts in the set:

1. 1091-17-01 - Press ring
2. 1091-17-02 - Press plate
3. 1091-17-03 - Press pipe
4. 1091-17-05 - Bearing plate\*
5. 1091-17-06 - Holder\*
6. 1091-17-08 - Press pipe
7. 1091-17-09 - Hub plate\*
8. 1091-17-M22 - Punching nut M22



\*Inner Ø 23 mm

### Used with (not included):

- 1091-17-04 - Bearing plate (included in 1091-15)  
1091-17-07 - Hub plate (included in 1091-15)

## 1091-18 Press ring for Citroën Jumper, Fiat Ducato & Peugeot Boxer 2007-

Is used instead of 1091-17-01 together with set 1091-17 on cars newer than 2007.



**NEW!**

## 1091-10 Wheel bearing set, front Ford Transit

The wheel bearing is replaced directly on the car with minimum dismantling. Also makes it possible to change a brake disc without dismantling the wheel bearing. **The set covers both sizes of Ford Transit, 78 mm and 87,5 mm.**  
Est.time: 25 min/side. Rec. cylinder 1090-05/03-00028.



### Parts in the set:

1. 1090-26-01 - Large press plate, double sided
2. 1090-26-02 - Large press pipe
3. 1091-10-04 - Hub plate\*
4. 1091-11 - Hub tool
5. 1091-17-04 - Bearing plate\*
6. 1091-17-08 - Press pipe

Note that 1090-26-01 and 1090-26-02 exist as own kit 1080-26.

\*Inner Ø 23 mm



## 02-0008 Wheel bearing set, rear Ford Transit

Puller set for Ford Transit rear wheel bearing. The tool can also be used in front when pressing out axle shafts from the hub.  
The nuts in the set are special made to fit Ford Transit M14x2 thread.  
The puller can be fitted on most five holed hubs, with other or original nuts.  
Rec. cylinder 1090-05/03-00028.



### Parts in the set

1. 5 pcs 04-00007-004 - Special nuts M14x2
2. 1091-28 - Axle shaft tool, 5 hole, lkw



## 1091-27 Hub puller for Iveco Daily 29-50

Tool for dismantling the wheel bearing/hub on Iveco Daily models 29-50.  
Rec. cylinder 1090-01/1090-02-WAL.

### Parts in the set

1. 3 pcs 1091-18-03 - Bolt M14x40
2. 1091-27-01 - Plate



## 1091-21 Wheel bearing set, front & rear dismounting VW T5 & Touareg

Set for dismounting front and rear wheel bearings.

Note! To mount the bearing use 1090-25.

Rec. cylinder 1090-01/1090-02-WAL.

### Parts in the set:

1. 1090-22 - Press clamp, axle shaft & hub
2. 2 pcs 1091-21-01 - Spacer bolt VW front
3. 1091-21-02 - Spacer plug VW front
4. 3 pcs 1091-21-03 - Spacer bolt VW rear, drum brake
5. 3 pcs 1091-21-04 - Spacer bolt VW rear

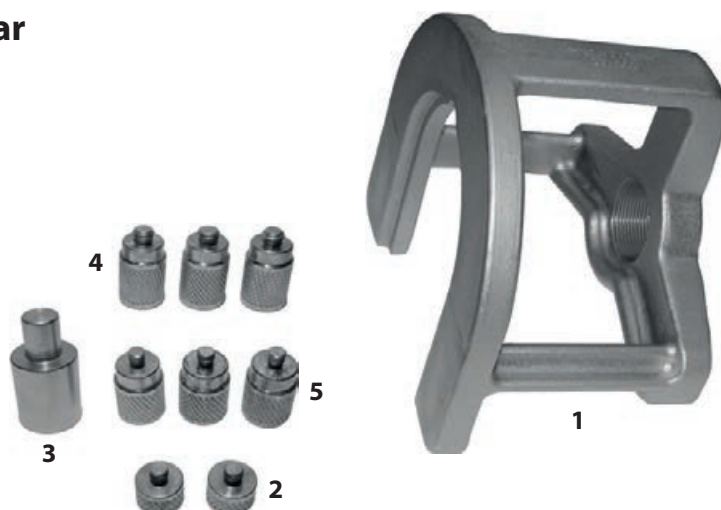

## 1091-21-10 Wheel bearing set, front & rear dismounting VW T5 & Touareg without 1090-22

Set for dismounting front and rear wheel bearings

(used with 1090-22). Rec. cylinder 1090-01/1090-02-WAL.

### Parts in the set:

1. 2 pcs 1091-21-01 - Spacer bolt VW front
2. 1091-21-02 - Spacer plug VW front
3. 3 pcs 1091-21-03 - Spacer bolt VW rear, drum brake
4. 3 pcs 1091-21-04 - Spacer bolt VW rear

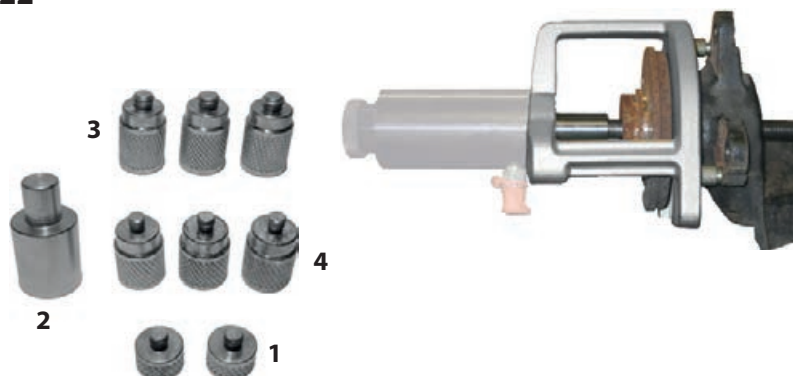

## 02-0006 Wheel bearing set rear MB Vito & Viano

Set for replacing of rear wheel bearings on Mercedes-Benz Vito and Viano 2003–2010

(W639). The bearings are replaced directly on the car without unnecessary dismounting.

The parts are designed to protect the ABS sensor from getting damaged and to install the lock ring at the same time as the bearing.

Est.time: 30 min/side. Rec. cylinder 1090-01/1090-02-WAL.

### Parts in the set:

1. 1090-20-06 - Hub plate 45mm\*
2. 1090-20-BX - Press plate for 1090-20-R4
3. 1090-20-R1 - Press pipe
4. 1090-20-T10 - Bearing plate 63mm\*
5. 1090-20-T16 - Bearing plate 77,8mm\*
6. 1090-22 - Press clamp, axle shaft & hub
7. 1090-25-12 - Bearing plate\*
8. 3 pcs 1091-21-04 - Spacer bolt rear

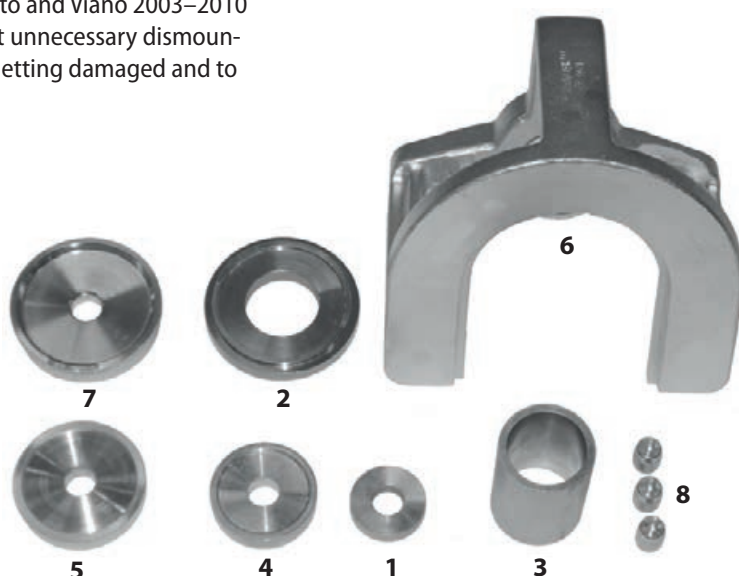

\*Inner Ø 20,25 mm

## 02-00007 Hub dismantling set Renault Master 1998-2003 with the brake disc inside of the hub.

This set is used with the front wheel bearing set 1091-23 for dismantling the hub and brake disc on Renault Master and similar models with the brake disc mounted inside of the wheel hub. With the set it's possible to press out the hub and brake disc with hydraulic power of 32 ton in combination with punching. For hub dismantling axle shaft tool 1091-28 is also required (not included in set).

### Parts in the set

1. 02-00007-001 - Press slice, 3 pcs
2. 02-00007-002 - Press cone
3. 02-00007-003 - Lid
4. 02-00007-004 - Dismounting ring
5. RES4024 - Flange nut M18

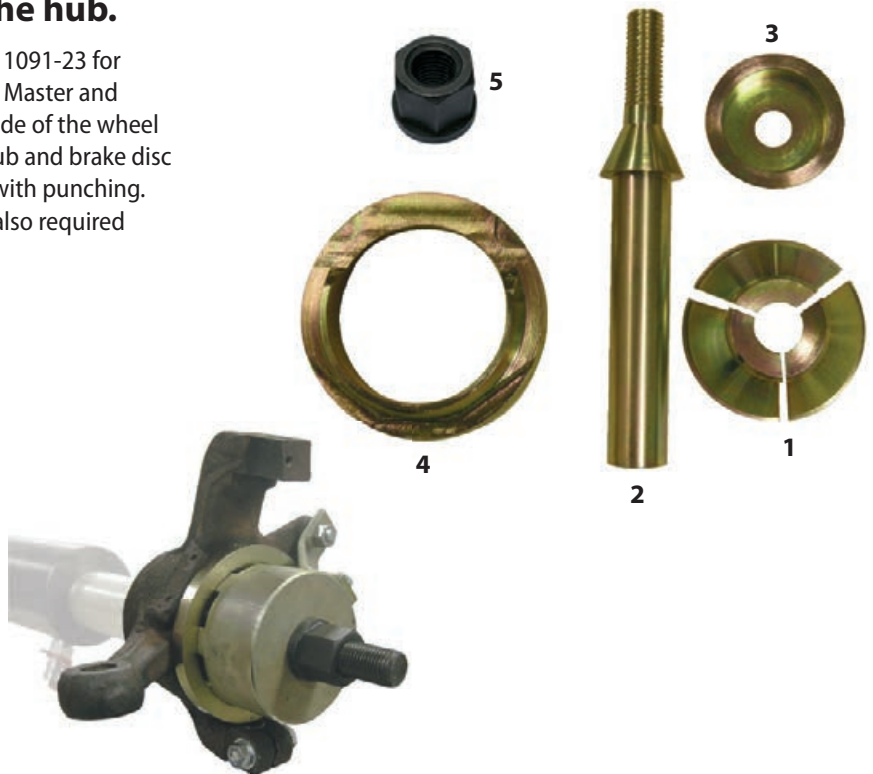

## 1091-28 Axle shaft tool, 5 holes, light commercial vehicles

This tool is specially developed for pressing out rusted & glued axle shafts directly on the vehicle. This job only takes 5 min. The holes for the wheel bolts are oval to fit on all light commercial vehicles with 5 holed hubs. With this equipment you avoid heating, splitting of the axle shaft or damage to other parts. Bolt on to the hub using the cars own wheel bolts, mount the cylinder, start pressing and for extra power fit a punching socket 1086-6 and then hammer on it. **Bolt dia 119-172 mm.**

Included in set 1091-15 and 02-00008.  
Rec. cylinder 1090-05/03-00028.



## 04-00007-001 Special bolt nut M16x1,5

Designed to be used with axle shaft tool 1091-28 when pressing axles or rear wheel bearings. Fits Peugeot Boxer, Citroen Jumper, Fiat Ducato, Renault Master and more. (5 pcs needed).



## 04-00007-004 Special nut M14x2

Designed to be used with axle shaft tool 1091-28 when pressing axles or rear wheel bearings. Fits Ford Transit. (5 pcs needed).





## 1091-22 Wheel bearing set, front Renault Trafic, Opel Vivaro 2002- & Nissan Primastar

Set for replacing front wheel bearings. The wheel bearing is replaced directly on the car with minimum dismounting.  
Est.time: 20-30 min/side.  
Rec. cylinder 1090-01/1090-02-WAL/1090-05/03-00028.

### Parts in the set:

1. 1090-20-M - Holder\*
2. 1090-20-R1 - Press pipe
3. 1090-20-T18 - Bearing plate 82,9mm\*
4. 1090-20-T20 - Bearing plate 87,8mm\*
5. 1091-10-04 - Hub plate\*\*
6. 1091-17-02 - Press plate
7. 1091-17-03 - Press pipe
8. 1091-22-01 - Bearing plate 57mm\*\*

\*Inner Ø 20,25 mm

\*\* Inner Ø 23 mm



## 1091-23 Wheel bearing set, front Renault Master, Opel Movano 2003-2010 & Nissan Interstar

Set for replacing front wheel bearings. The wheel bearing is replaced directly on the car with minimum dismounting.  
Est.time: 40 min/side. Rec. cylinder 1090-05/03-00028.

### Parts in the set:

1. 1091-10-04 - Hub plate\*
2. 1091-17-02 - Press plate
3. 1091-17-03 - Press pipe
4. 1091-17-04 - Bearing plate\*
5. 1091-17-08 - Press pipe
6. 1091-23-01 - Press ring
7. 1091-23-02 - Bearing cup
8. 1091-23-03 - Press plate\*
9. 1091-23-04 - Press plate\*

\*Inner Ø 23 mm



## 02-00010 Front wheel bearing set Renault Master Nissan Interstar & Opel Movano 2010 -

Set for replacing front wheel bearings. The wheel bearing is replaced directly on the car with minimum dismounting. If earlier set 1091-23 is in use, only 02-00010 and 1091-18 is required for models after 2010.  
Est.time: 40 min/side. Rec. cylinder 1090-05/03-00028.

### Parts in the set:

- |                               |                                |
|-------------------------------|--------------------------------|
| 1. 02-00010-001 - Presssocket | 5. 1091-17-04 - Bearing plate* |
| 2. 1091-10-04 - Hub plate*    | 6. 1091-17-08 - Press pipe     |
| 3. 1091-17-02 - Press plate   | 7. 1091-18 - Press ring        |
| 4. 1091-17-03 - Press pipe    | 8. 1091-23-03 - Press plate*   |

\*Inner Ø 23 mm



# Ball-joint and bushing sets

Used with press block 1090-60 and hydraulic cylinder 1090-03, 1090-01 or 1090-02-WAL.

## 1090-60 Press block

Strong and flexible press block for replacing of ball-joints, bushings and more. Can also be equipped with 1090-60-05 (open side) to become a 1090-69.

Replace a ball-joint or bushing in 5-10 minutes.

### Consists of:

1. 1090-60-01 - Plate with thread
2. 1090-60-02 - Plate w/o thread
3. 2 pcs 1090-60-03 - Support rod
4. 4 pcs 1090-60-04 - Bolt M16x40mm

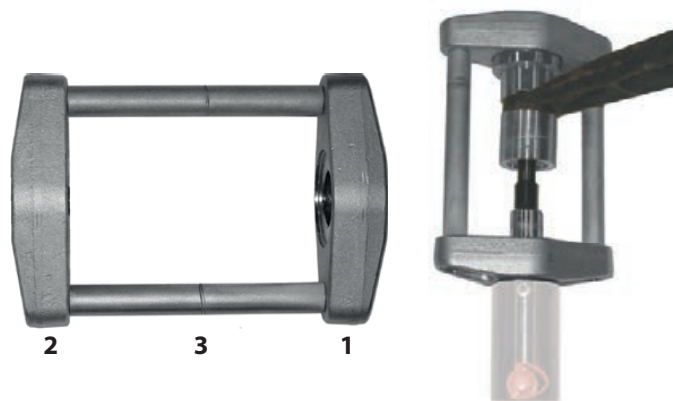

## Brand specifications for ball-joint tools

Car model	Part no
BMW E30, E36 (inner)	1090-62-01, 1090-62-02, 1090-62-03
BMW E36 outer	1090-61-01, 1090-61-02, 1090-61-03
MB 124	1090-62-01, 1090-62-02, 1090-64-01
MB Sprinter	1090-66-01, 1090-66-03
MB Sprinter 2007-	1090-66-08, 1090-66-09, 1090-66-10
Dacia Logan I (2006-2013), Renault Clio III (2006-2013), Renault Grand Scenic I (2003-2009), Renault Laguna I, Renault Megane II, Renault Modus (2005-2013), Renault Senic II	1090-62-01, 1090-68-01, 1090-68-02
Nissan Interstar, Opel Movano, Renault Master	
Upper:	1090-66-04, 1090-66-06
Lower:	1090-62-08, 1090-66-04, 1090-66-05
VWT4	1090-66-01, 1090-66-04
VW LT 35	1090-66-01, 1090-66-03
VW Crafter	1090-66-08, 1090-66-09, 1090-66-10
Hyundai Trajet, Santa Fe	1090-66-05, 1090-66-07, 1090-68-01

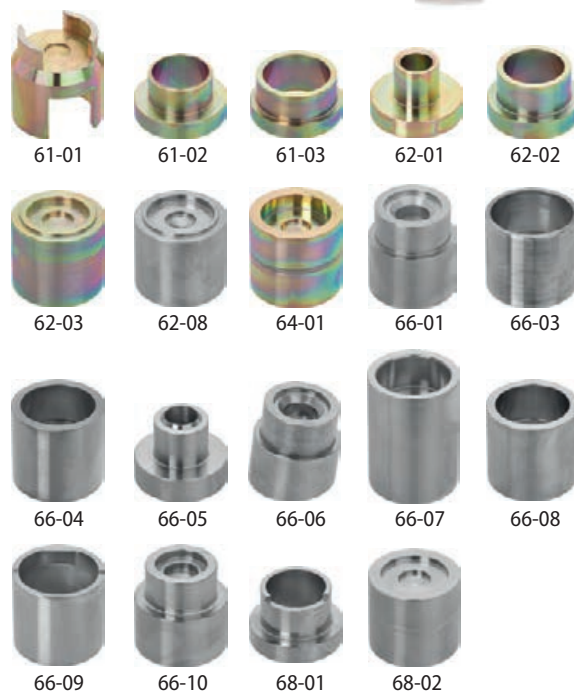

## 1090-36 Supporting arm bushing set, rear, front bushings – for Opel Vectra & Saab 9-5

Set for quick exchanging of front bushing in rear supporting arm.  
Developed with Saab/Opels main auto repair shops in Sweden.  
Est.time: 20 min/side.

### Parts in the set:

1. 1090-36-01 - Press plate
2. 1090-36-02 - Press pipe
3. 1090-36-03 - Press socket
4. 1090-36-04 - Press plate
5. 1090-36-05 - Spacer plug



## 1090-68-20 Suspension bushing, rear – for Renault Laguna II

Set for quick exchanging of rear suspension bushing.  
Est.time: 10 min/side.

### Parts in the set:

1. 1090-68-03 - Press socket
2. 1090-68-04 - Press socket
3. 1090-68-05 - Press socket

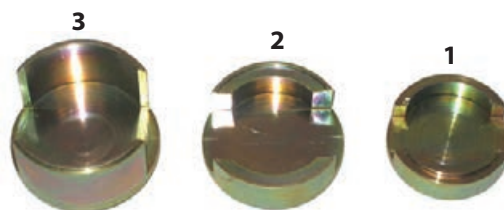

Used with press block 1090-69 and hydraulic cylinder 1090-03, 1090-01 or 1090-02-WAL.

## 1090-69 Press block, open plate

Strong and flexible press block for replacing of ball-joints, bushings and more. Can also be equipped with 1090-60-02 to become a 1090-60.

Replace a ball-joint or bushing in 5-10 minutes.

### Consists of:

1. 1090-60-01 - Plate with thread
2. 2 pcs 1090-60-03 - Support rod
3. 4 pcs 1090-60-04 - Bolt M16x40mm
4. 1090-60-05 - Plate with open side

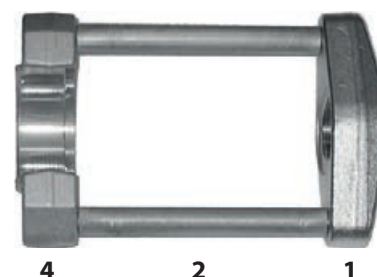

## 1090-60-06 Adapter plate

For mounting in press block 1090-69. The adaptor gives the same measure in the bottom part as the closed press block 1090-60.



## 1090-39 Suspension bushing set, rear for Audi A3, Seat Ibiza, Skoda Fabia & VW Golf IV

Set for replacing the rear suspension bushings quick & easy . The set is used with a press block 1090-69 instead of using a fragile threaded bolt through the bushing when dismounting. 1090-69 is not included in set. Est.time: 20 min/side.

### Parts in the set:

1. 1090-39-10 - Press pipe
2. 1090-39-06 - Dismounting cup
3. 1090-39-08 - Mounting cup
4. 1090-39-09 - Mounting ring

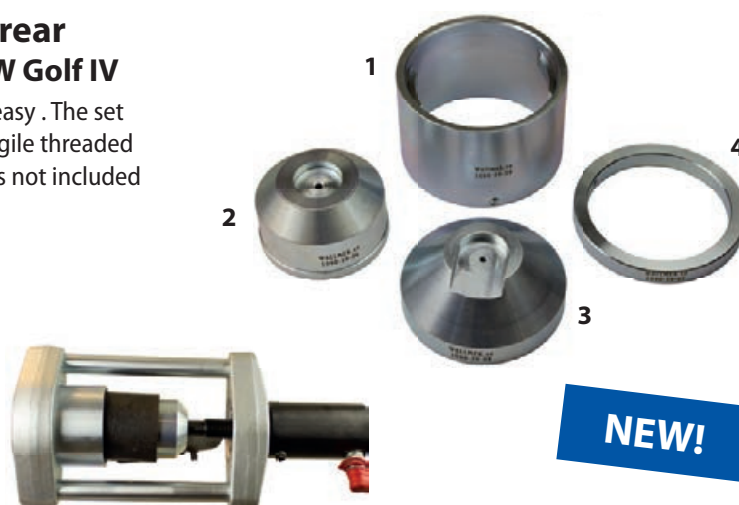

## 1090-69-10 Supporting arm bushing set, rear for Mitsubishi Carisma 1996- & Volvo V40/S40 1996-2004

Set for quick exchanging of front bushing in rear supporting arm. Est.time: 20 min/side.

### Parts in the set:

1. 1090-69-11 - Mounting plate
2. 1090-69-12 - Shrinking pipe
3. 1090-69-13 - Holding pipe
4. 1090-69-14 - Press plate



Used with cylinders 1090-01, 1090-02-WAL or 1090-03.

## 01-00022 Bushing set for replacement of the front bushing on the rear trailing arm on Volvo S60, S80, V60, V70, XC60 and XC70 2007- Ford Mondeo, S Max, Galaxy 2007-

Using the tool the rear suspension bushing can be replaced directly on the vehicle with a minimum of dismantling. Only takes 30 minutes per side. The exposed position of the bushing results in rust and difficulty in removing, the recommended cylinders are from 14 - 22 ton and are screwed in to the press block.

Recommended hydraulic cylinders:  
1090-03, 1090-02 and 1090-01.

Do not load the block or bushing with more than 16 ton!!

### Parts in the set:

1. 01-00022-020 - Press fixture
2. 01-00022-003 - Press pipe
3. 01-00022-004 - Thrust washer
4. 01-00022-005 - Adapter ring
5. 1090-60-01 - Plate with thread
6. 2 x 1090-60-04 - Bolt M16x40mm



## 01-00022-010 Bushing set for existing blocks

When press block 1090-60 or 1090-69 is already owned, 01-00022-010 can be ordered instead. The threaded block section is then fitted on the tool to be used, see 01-00022.

### Parts in the set:

1. 01-00022-020 - Press fixture
2. 01-00022-003 - Press pipe
3. 01-00022-004 - Thrust washer
4. 01-00022-005 - Adapter ring



## 1090-69-20 Supporting arm bushing set, rear for Ford Focus 1999-, Mazda 3 2004- & Volvo V50/S40 2004-

Set for quick exchanging of front bushing in rear supporting arm. Est.time: 20 min/side. To be used with bushing set 01-00022 or press block 1090-69.

### Parts in the set:

1. 1090-69-21 - Dis-/mounting socket
2. 1090-69-22 - Mounting plate
3. 1090-69-23 - Holding ring
4. 1090-69-24 - Press plate



Used with press block 1090-55 and hydraulic cylinder 1090-03, 1090-01, 1090-02-WAL or 03-00015.

### 1090-55-B Press block, max 16 ton

This forged press block allows access to change the ball-joints and sway arm bushings on Mercedes-Benz 211 and 220. No further reinforcement is necessary, even when pressing with 16 ton. Replace a ball-joint or bushing in 5-10 minutes.



### 1090-54-10 Ball-joint set for MB 211 & 220

Set for replacing ball-joints on Mercedes-Benz 211 and 220. No need for dismantling of brake components or reprogramming of the onboard computer.

**Parts in the set:**

1. 1090-54-03 - Press socket
2. 1090-54-04 - Mounting socket
3. 1090-54-05 - Dismounting socket
4. RES 1090-01-12 - Adjustable press rod 132mm, M24

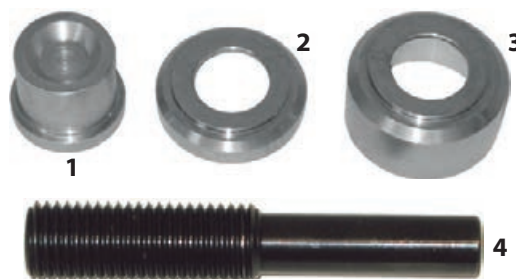

### 1090-54-11 Sway bar ball-joint set for MB 211 & 220

Set for replacing sway bar ball-joints on Mercedes-Benz 211 and 220. The only parts you have to dismount is the sway bar itself. No need for dismantling of shock absorbers or lower slewing bracket fittings.

**Parts in the set:**

1. 1090-54-01 - Press socket
2. 1090-54-02 - Press socket

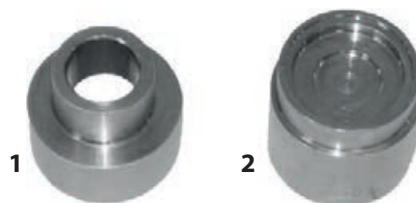

### 1090-54-06 Ball-joint dismounting socket for Mercedes-Benz ML

Socket for dismounting ball-joints on Mercedes-Benz ML. Is used with 1090-54-10.



### 02-00009 Ball-joint set Ford Transit

A set for quick and easy replacement of ball-joints on Ford Transit. The work is made directly on the car with a minimum of dismantling. Est.time: 10 min.

**Parts in the set:**

1. 02-00009-001 press pipe
2. 02-00009-002 Lid
3. 02-00009-003 Mounting socket
4. 02-00009-004 Demounting socket



## 1090-54-12 Suspension arm bushing set, rear for MB C, E and S class

Set for replacing of rear, lower bushing in rear suspension arm.

### Parts in the set:

1. 1090-54-12-001 - Dismounting socket
2. 1090-54-12-002 - Mounting socket
3. 1090-54-12-003 - Press pipe
4. 1090-54-12-004 - Holding ring, mounting
5. RES4021 - Flange nut M14
6. RES4016 - Carriage beam M14, 250mm
7. RES4010 - Adaptor M22-M14

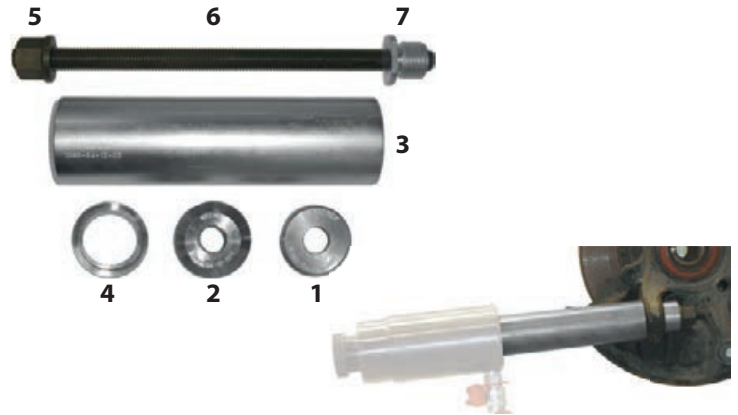

## 1090-37 Supporting arm bushing set, rear bushings & sub frame bushings for Opel Vectra & Saab 9-5

Set for quick exchanging of rear bushings in rear supporting arm (4pc) and subframe bushings (6pc). The job is done without unnecessary dismantling of sub frame or supporting arms.

### Parts in the set:

1. 1090-37-BL1 - Press socket, dismounting
2. 1090-37-BL2 - Press socket, mounting
3. 1090-37-BL3 - Holding ring, mounting
4. 1090-37-SU1 - Press socket, mounting
5. 1090-37-SU2 - Press socket, dismounting
6. 1090-37-SU3 - Holding ring, mounting
7. 1090-37-SU4 - Press pipe
8. RES4010 - Adaptor M22-M14
9. RES4011 - Adaptor M22-M12
10. RES4015 - Carriage beam M12, 250mm
11. RES4016 - Carriage beam M14, 250mm

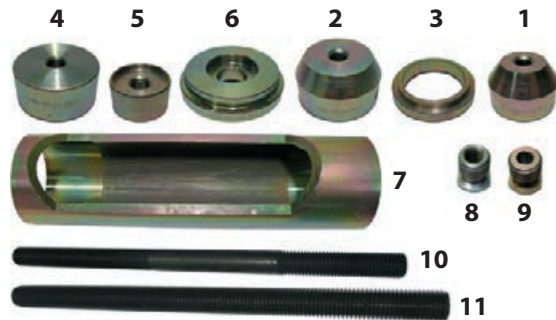

## 1090-07 Engine mount bushing set for Volvo 850 & V70

Set for replacing the upper engine bushing.  
Replace the bushing direct on the car.

### Parts in the set:

1. 1090-07-01 - Press plate
2. 1090-07-02 - Press pipe
3. 1090-07-03 - Mounting pipe
4. RES4011 - Adaptor M22-M12
5. RES4015 - Carriage beam M12, 250mm
6. RES4022 - Flange nut M12

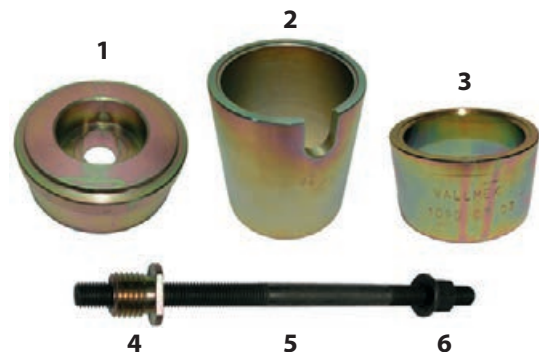

## 01-00009 Silent bushing set rear BMW E60-65 & E90, complete set

Set for replacing rear silent bushings on (5, 6, and 7 ser) and (1 and 3 ser).  
No need for dismounting of anything else then the bushings own bolts and replacing all 4 bushings takes about 45 minutes.

### Parts in the set:

1.	1090-18-E5	Press pipe Touring
2.	1090-18-E6	Press plate Touring
3.	1090-18-D5	Mounting plate E38 & E39
4.	1090-15-B	Press socket
5.	1090-15-C	Press plate
6.	1090-15-B3	Holding ring E32 & E34
7.	1090-14-B6	Holding ring
8.	1090-14-D6	Mounting plate
9.	RES4026	Carriage beam M18/M22, 250mm
10.	RES4029	Carriage beam M18/M22, 180mm
11.	01-00009-001	Mounting ring
12.	01-00009-002	Holding ring
13.	01-00009-003	Threaded plate
14.	01-00010-001	Threaded plate
15.	01-00010-002	Press plate
16.	01-00010-003	Holding ring
17.	01-00010-004	Mounting ring
18.	01-00011-001	Threaded plate
19.	RES4010	Adaptor M22-M14
20.	RES4016	Carriage beam M14, 250mm
21.	1090-15-D	Holding plate E32 & E34



### 01-00009-101 Silent bushing set,

Included in 01-00009. Add on set for BMW E60-65 and E90.  
Use with 1090-14-10, 1090-15, 1090-18 and 1090-19.

11.	01-00009-001	Mounting ring
12.	01-00009-002	Holding ring
13.	01-00009-003	Threaded plate
14.	01-00010-001	Threaded plate
15.	01-00010-002	Press plate
16.	01-00010-003	Holding ring
17.	01-00010-004	Mounting ring
18.	01-00011-001	Threaded plate
19.	RES4010	Adaptor M22-M14
20.	RES4016	Carriage beam M14, 250mm
21.	1090-15-D	Holding plate E32 & E34



### 1090-16 Supporting arm bushing set

(use with set 1090-15) BMW E36/E46 silent bushing rear supporting arm & lower rear ball-joint for E38/E39.

1.	1090-16-C2.	Press socket E38 & E39
2.	1090-16-C3.	Holding socket E38 & E39
3.	1090-20-R1.	Press pipe
4.	1090-16-C1.	Press socket E38 & E39
5.	1090-16-B4.	Holding ring E36 & E46
6.	1090-16-D4.	Threaded plate E36 & E46
7.	1090-16-A4.	Press plate E36 & E46
8.	RES4022.	Flange nut M12
9.	RES4015.	Carriage beam M12, 250mm
10.	RES4011.	Adaptor M22-M12

The set is used with the following, not included.

1090-15-B	Press socket (included in 1090-15)
RES4010	Adaptor M22-M14
RES4016	Carriage beam M14, 225mm
RES4021	Flange nut M14

### 1090-16-10 Ball-joint/bushing set lower rear BMW E38/39/60

The steel bushing is replaced directly on the car, break disk etc is not needed to dismount. These parts are also included in set 1090-16, see list above. RES4010, RES4016 and RES4021 are included in the set.



Used with cylinders 1090-01 or 1090-02-WAL.

## 1090-15 Silent bushing set, rear for BMW E28, E30, E32 & E34

Set for replacing rear silent bushings. No need for dismantling of the rear axle and replacing all 4 bushings takes 45 minutes.

**1090-19** Used with 1090-18 for E38 and E39.

### Parts in the set:

1. 1090-15-A1 - Threaded plate E30
2. 1090-15-A2 - Threaded plate E28
3. 1090-15-A3 - Threaded plate E32 & E34
4. 1090-15-B - Press socket (included in 1090-19)
5. 1090-15-B1 - Holding ring E30
6. 1090-15-B2 - Holding ring E28 (included in 1090-19)
7. 1090-15-B3 - Holding ring E32 & E34 (included in 1090-19)
8. 1090-15-C - Press plate
9. 1090-15-D - Holding plate E32 & E34
10. 1090-15-D1 - Mounting ring E30
11. 1090-15-D2 - Mounting ring E28

### Used with following (not included):

- RES4010 - Adapter M22-M14  
RES4016 - Carriage beam M14, 250 mm



## 1090-18 Silent bushing set, rear for BMW E38 & E39, including touring

Set for replacing rear silent bushings on BMW E38 and E39, including touring. (use with set 1090-15 or 1090-19). No need for dismantling of anything else then the bushings own bolts and replacing all 4 bushings takes 45 minutes.

### Parts in the set:

1. 1090-18-A5 - Threaded plate
2. 1090-18-B5 - Holding ring
3. 1090-18-D5 - Mounting plate E38 & E39
4. 1090-18-E5 - Press pipe Touring
5. 1090-18-E6 - Press plate Touring
6. RES4026 - Carriage beam M18/M22, 250mm
7. RES4029 - Carriage beam M18/M22, 180mm



## 1090-14 Silentbushing set, rear for BMW X5, E53

Set for replacing rear silentbushings on BMW X5, E53. Replace all 4 bushings in 45 minutes.

**1090-14-10** Used with 1090-18 for X5, E53 silent bushing.

### Parts in the set:

1. 1090-14-A6 - Threaded plate (included in 1090-14-10)
2. 1090-14-B6 - Holding ring (included in 1090-14-10)
3. 1090-14-D6 - Mounting plate (included in 1090-14-10)
4. 1090-15-B - Press socket
5. 1090-15-C - Press plate
6. 1090-18-E5 - Press pipe Touring
7. 1090-18-E6 - Press plate Touring
8. RES4026 - Carriage beam M18/M22, 250mm

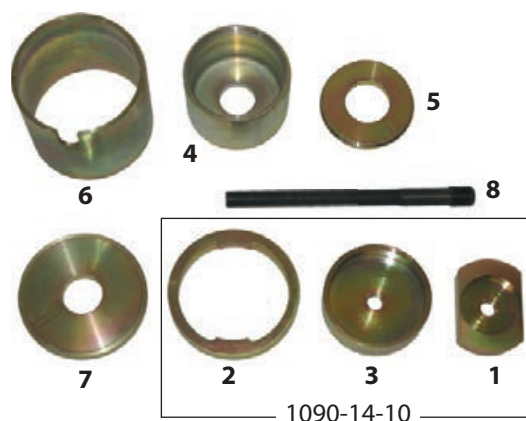



## 01-00014 Rear axle bushing set Hyundai Santa Fe 2006-2012

Set for replacement of all four bushings in the rear axle. The job is made directly on the car with hydraulic power. The rear axle is lowered with help of a gear box lift for easy access to the bushings. Est.time: 60 min.



### Parts in set

1. 01-00014-001 - Press pipe
2. 01-00014-002 - Press plate
3. 01-00014-003 - Dismounting plate
4. 01-00014-004 - Press plate
5. 01-00014-005 - Mounting plate
6. 01-00014-006 - Dismounting plate
7. 01-00014-009 - Dismounting ring
8. 1090-20-R1 - Press pipe



## 1091-13 Slewing bracket bushing set, front Ford Transit

Set for replacing of the rear bushing in the front slewing bracket.

### Parts in the set:

1. 1091-13-01 - Press socket
2. 1091-13-02 - Press pipe
3. RES4010 - Adaptor M22-M14
4. RES4016 - Carriage beam M14, 250mm
5. RES4021 - Flange nut M14

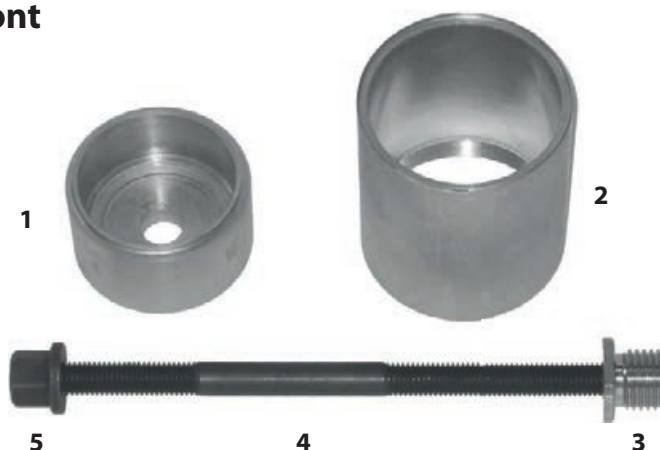

## 1090-09 Slewing bracket bushings set, front Volvo S60 2001-2010, V70 2000-2008, S80 1999-2008

Set for quick exchanging of front slewing bracket bushings. (For use in a work shop press). Only replace the bushings instead of the whole bracket. The benefit of this is that you can mount a stiffer and more durable bushing, a bushing is cheaper and you save money on storage space.

### Parts in the set:

1. 1090-09-01 - Press socket front bushing
2. 1090-09-02 - Press socket front bushing, large
3. 1090-09-03 - Press plate for 1090-09-02
4. 1090-09-04 - Press socket rear bushing
5. 1090-09-05 - Press pipe rear bushing



## 1062-01 Control arm bushing set, front for VW Polo 9N & equivalent models on Audi, Seat & Skoda

Set for replacing of the rear bushing of the front control arm. This set is for manual use.

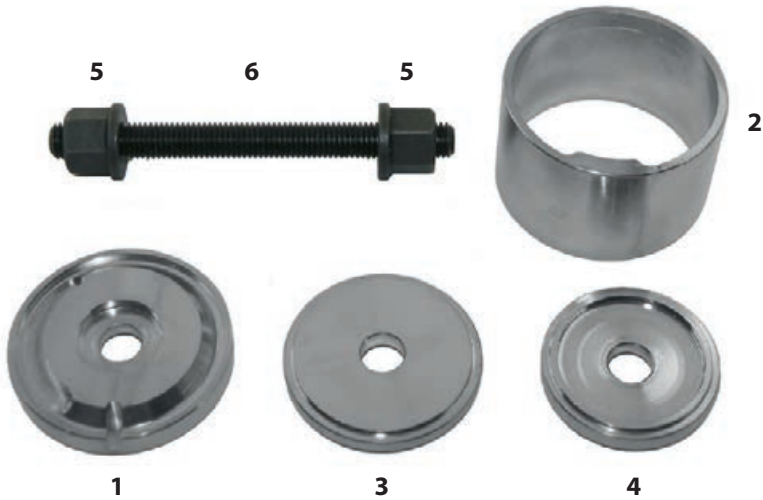

### Parts in the set:

1. 1062-01-01 - Dis-/mounting plate
2. 1062-01-02 - Press pipe
3. 1062-01-03 - Mounting plate
4. 1062-01-04 - Dismounting plate
5. 2 pcs RES4021 - Flange nut M14
6. RES4028 - Carriage beam M14, 150mm



### Fits for:

Audi A2 2000-2005  
VW Polo PN 2001-, Fox 2005-  
Skoda Fabia 2000-, Roomster 2006-  
Seat Cordoba, Ibiza 2002-



### Fits for:

Audi A3 2003-  
VW Caddy III, Eos 2006-, Golf V 03-, Jetta III 2005-,  
Passat 2005-, Touran från 2003-, Tiguan 2007-  
Seat Altea 2004-, Leon 05-, Toledo 2004-  
Skoda Octavia 2004-

## 1064-05 Ball-joint tool set Volvo S60, V70, S80 & XC90

This set allows quick and easy replacement of ball-joints with the striking tool.

### Parts in the set

1. 1064 – Striking tool Bamse
2. 1064-05-01 - Adaptor M12-M18, V70, S60, S80
3. 1064-05-02 – Mounting socket
4. 1064-05-03 - Adaptor M14-M18, XC90



## 01-00023 Bushing set for replacement of gear box supporting bushing in front sub frame

VW: Caddy III (2004-2010), Eos (2006-), Golf V (2003-2009), VI (2008-), Scirocco (2005-), Jetta III (2005-2010), Passat (2005-2010), Tiguan (2007-), Touran (2003-). SEAT: Altea (2004-), Leon (2005-), Toledo (2004-2009). SKODA: Octavia (2004-2010). AUDI: A3 (2005), TT (2006-2010).

The set is used in the garage press due to limited access under the vehicle. With this set the bushing in the engine supporting bushing in front sub frame is replaced quick and easy.

### Parts in the set:

1. 01-00023-001 - Compression pipe
2. 01-00023-002 - Press plate
3. 01-00023-003 - Press pipe

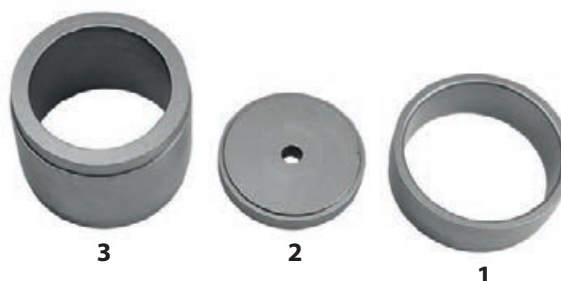

## 01-00025 Bushing set rear in front support arm VW T5

Replacement is carried out directly on the vehicle with a minimum of dismantling. A basic set that gives great time savings, labour time about 15 minutes.

### Parts in the set:

1. 01-00025-001 - Press plate
2. 01-00025-002 - Sleeve
3. RES4010 - Adapter M22-M14
4. RES4016 - Carriage beam M14, 250 mm
5. RES4021 - Flange nut M14



## Hydraulic spring compressor no: HSC2008

This unique spring compressor is designed to be a helpful and efficient tool when working with wheel suspensions. With unique adjustment possibilities and special jaws it covers almost every front and rear spring on light commercial vehicles all the way down to small passenger cars. It also covers models like Mercedes C-class and newer BMW models. 150-240 mm Ø.

It allows the mechanic to compress the spring and split the shock absorber unit from the wheel spindle directly on the car. The same function can also be used to unload the lower control arm to its "normal" position when working with ball-joints or sway bars. It can also be used as a helping hand when working with other jobs on the suspension system, see below. The unit is mobile and can be used anywhere in the shop. It comes with a safety strap for extra safe handling.

Used with hydraulic pump (700 bars) **1030**, **1035** or **1036**.

### Included products:

4 pcs HSC2008-1116 - Claw  
09-000016 - Strap  
HSC2008-1126 - Top part  
HSC2008-1127 - Pipe

CE

2,1 ton



A lot of time can be saved with this function. It allows the mechanic to compress the spring and split the shock absorber unit from the wheel spindle directly on the car. The same function can also be used to unload the lower control arm to its "normal" position when working with ball-joints or sway bars.



09-00016 – Security strap

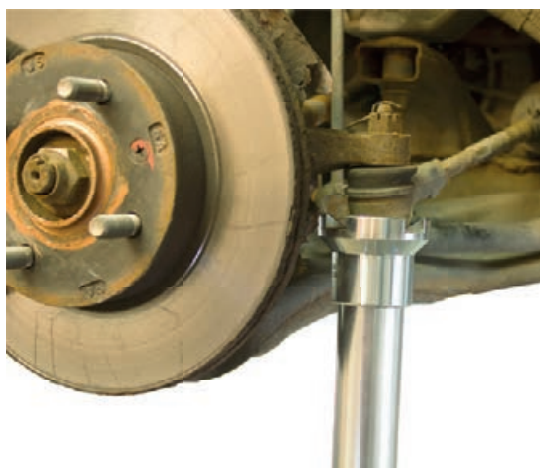

HSC2008-1126

HSC2008-1127

The unit can be used as a helping hand when working with other jobs on the suspension system. In this sample a ball-joint is pressed up to avoid spinning when fasten it with the locking nut.



**HSC2008-1146 Claw for Ø 150–240 mm, 4 pcs**

Included in HSC2008.



**Special claw ordered separatly, not included.**

**HSC2008-1147 Claw for Ø 70–160 mm, 4 pcs**

Specially designed claw for multi link front suspensions like MB 220 with a smaller diameter than standard MacPhearson type. The claws are used for springs from 70 – 160 mm Ø. (4 pcs needed).



**HSC2008-1118-020 Claw for Ø150-240 mm, 2 pcs**

Specially designed for like Chrysler Voyager 1996-2007. (2 pcs needed).



# Press tool sets

## 01-00001 Universal press tool set 1

A flexible, well thought-out and very useful set for bushings, ball-joints, certain bearings and more. Can also be delivered complete in a robust plastic case as **01-00006**.

The set consists of 24 pc, with sizes ranging from 30,5 to 79,7 mm with small increments. Many of them have two usable sides to increase the number of combinations to 61!

An adaptor and a press rod are included to be able to use press block 1090-60. This is very useful when working with bushings and ball-joints without holes.

The larger sockets are made to fit bushings like the inner supporting arm bushings on BMW E38/E39 and Mercedes E/S class. The set is delivered like in the picture with a foam that holds the pieces in place, may also be wall mounted.

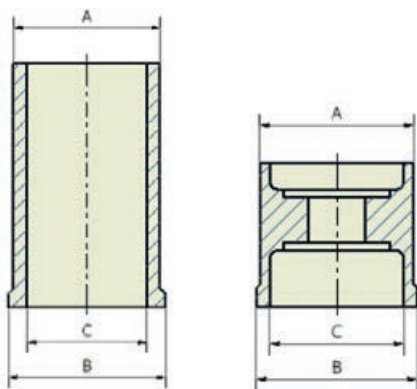

### Universal set 1

001-00001-001	– Adaptor plate		
01-00001-002	– Adjustable press axle 90mm, M24		
Press pipes art:	∅ A mm	∅ B mm	∅ C mm
01-00001-101	40,7	42,5	35,2
01-00001-102	43,7	45,5	38,2
01-00001-103	46,7	48,5	41,2
01-00001-104	49,7	51,5	44,2
01-00001-105	52,7	54,5	47,2
01-00001-106	55,7	57,5	50,2
01-00001-107	58,7	69,5	53,2
01-00001-108	61,7	63,5	56,2
01-00001-109	65,7	67,5	60,2
01-00001-110	69,7	71,5	64,2

Press pipe art:	∅ A mm	∅ B mm	∅ C mm
01-00001-201	38,7	44,7	30,5
01-00001-202	41,7	44,7	34
01-00001-203	44,7	44,7	37,2
01-00001-204	47,7	55	40,2
01-00001-205	50,7	55	43,2
01-00001-206	53,7	55	46,2
01-00001-207	56,7	55	49,2
01-00001-208	59,7	70	52,2
01-00001-209	62,7	70	55,2
01-00001-210	65,7	70	58,2
01-00001-211	68,7	70	61,2
01-00001-212	71,7	70	64,2
01-00001-213	75,7	75,7	68,2
01-00001-214	79,7	79,7	72,2

## 01-00002 Universal press tool set 2

A well thought-out and very useful set that is used with 01-00001 for even greater flexibility. Can also be delivered complete in a robust plastic case as **01-00007**.

The set consists of 10 different press rings with sizes ranging from 52,2 to 81,2 mm in small increments, an open bottom part for press block 1090-60 and an adaptor plate that makes it possible to use Wallmeks other ball-joint tools in the open press block. It is very useful when working with bushings and ball-joints without holes. The set is delivered like in the picture with a foam that holds the pieces in place, may also be wall mounted.

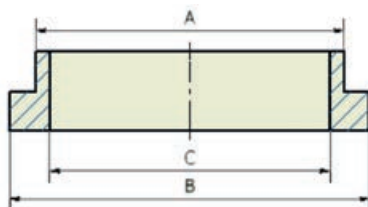

### 01-00002 Universal set 2

1090-60-05 Plate, open

Press ring	∅ A mm	∅ B mm	∅ C mm
01-00001-301	59	70	52,2
01-00001-302	62	70	55,2
01-00001-303	65	70	58,2
01-00001-304	68	70	61,2
01-00001-305	71	90	64,2
01-00001-306	74	90	67,2
01-00001-307	77	90	70,2
01-00001-308	80	90	73,2
01-00001-309	84	90	77,2
01-00001-310	88	90	81,2

01-00002-001 Foam

1090-60-06 Adapter

1090-60-05 Plate with open side

## 1011 Crank for brake disc

Crank for turning the brake disc when using scraper 1012 to clean the outer edge of it from rust.

## 1012 Scraper for brake disc

Scraper for cleaning the outer edge of brake discs and the position of the brake pads from rust. It's also possible to use crank 1011 for turning the brake disc when cleaning the brake disc.



## 01-00004 Lock ring tool

A new type of lock ring tool which makes dismounting and mounting of wheel bearing lock rings very easy. The tool is designed to fit both passenger cars, light commercial vehicles and trucks. The adjusting screw has a ¼" ratchet grip which provides enough power to easily remove stuck and rusted lock rings. The grip angle between the tips will also always be correct no matter the size or position of the lock ring.

This makes the tool safer, more effective and easier to use than ordinary pliers. It's delivered with a total of 6 specially designed tips that can easily be switched if needed.

- 01-00004-013 Circlip pin 2,5 mm, 4pcs
- 01-00004-014 Circlip pin 3 mm, 4pcs
- 01-00004-015 Circlip pin 3,5 mm, 4pcs



## 03-00014-001 Steering joint puller

Press clamp for dismounting steering joints on trucks/buses and ball-joints on light commercial vehicles.

The clamp is special designed to fit on most steering axles and ball-joints on light commercial vehicles, heavy trucks and buses on the market. Moulded with special steel to withstand greater force.

Used with 8,5 ton cylinder 03-00015.

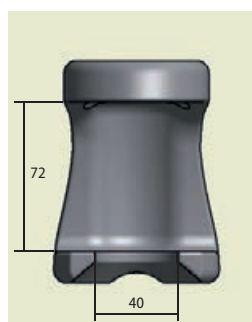

# Fuel handling for Petrol, Diesel and Ethanol (E85)

An efficient and very safe way to handle fuel. This drainer has no moving pump parts, this gives a very long life time compared to mechanical devices.



## L1050-E Fuel tank drainer 115L

The fuel tank drainer is made of stainless steel with a volume of 115 litres approved for petrol, diesel and ethanol. It uses vacuum when draining the car, and pressure when emptying the fuel drainer. It is delivered with a set of adaptors and a special hose for long and complicated fuel filler necks (No: L1063). The suction hose uses a quick coupling for a fast, easy and tight connection. The fuel drainer is equipped with an overfill protector, safety vent and pressure regulator. Large wheels makes it mobile and easy to move. SAQ Approval TO 194/92 – 175 950. The fuel drainer has a very long lifetime since it does not have any movable parts that can get damaged by fuel or particles. Safe, fast (max 15 l/ min) and quiet operation. Fumes are disposed of through an exhaust hose. Adaptors No: 1, 2 and 3 are included in No: L1050-E.



### Comes with the drainer:

- L1054-1 Fuel refill pipe
- L1054-2 Suction adaptor, coned
- L1063 Stainless steel hose with quick coupling for draining fuel through long, bent and complicated fuel tank filler necks with L1050 and L1050-E.  
Diameter: 12mm. Length: 1,9m. Suction capacity: 7 litres/min.

### Accessories

- 1. L1054-1 Fuel refill 15 litres/min
- 2. L1054-2 Suction adaptor, coned 7 litres/min
- 3. L1055-1 Adaptor male/female 8mm pipe
- 4. L1055-2 Adaptor male/female 9,5mm pipe
- 5. L1055-3 Adaptor male/female 10mm pipe
- 6. L1055-4 Adaptor male/female 12mm pipe
- 7. L1055-5 Adaptor female 14mm pipe

### Fuel suction hoses for long, bendt and complicated fuel filler necks:

- 8. L1063 Fuel suction hose 12mmØ, 1,9m Suction capacity: 7 litres/min
- 9. L1063-2 Fuel suction hose 8,5mmØ, 2,25m Suction capacity: 2,5 litres/min
- 10. L1063-4 Fuel suction hose 12mmØ, 3m 7 litres/min
- 11. 05-00007 Fuel suction hose with pipe for Volvo S80 (2007-) S80L, V70, XC60, XC70 (2008-).  
The pipe makes it possible to also drain the passive half of the fuel tank.
- 12. 05-00008 Fuel suction hose with pipe for Volvo V60 – S60, (2011-).  
The pipe makes it possible to also drain the passive half of the fuel tank.
- 13. L1063-2 Fuel suction hose 8,5mmØ, 3m Suction capacity: 2,5 litres/min
- 14. 05-00006 Adaptor for lid less filling (petrol/E10-85) filling necks.  
Unlocks and gives acces for draining and filling of fuel.
- 15. 05-00010 Adaptor for lid less filling (diesel) filling necks.  
Unlocks and gives access for draining and filling of fuel..



8, 9, 10, 13

12





### 05-00001 Liquid indicator 1/2"

For mounting on the fuel tank drainer fuel hose. 1/2" pipe thread.

### L1045 Fuel filter drainer

Clamp for draining of fuel filters with L1050 and L1050-E. Drains the filter before dismounting to avoid spill and keep the amount of fuel fumes in the workshop at a minimum. Punctures steel, aluminium and plastic filters. Connect to L1050 or L1050-E.



### L2015 Water separator Petrol, Diesel and Ethanol (E85)

Cleans petrol and diesel effectively from water and particles. For mounting on fuel tank drainer no: L1050-E. Easy inspection through sight glass. Drains from bottom valve. Volume 3,5 litres. Picture shows separator mounted on fuel tank drainer.



### L2620 Fuel fume evacuating hose

Hose unit for evacuating petrol and diesel fumes away from the vehicle during the work with fuel tanks. It can also be used when draining and filling the car. When working with an open fuel tank armature the mechanic is exposed to petrol fumes and the car's interior can smell of fuel afterwards. This is avoided by sucking out the fumes through the fuel refill pipe. The evacuating hose is powered by a compressed air ejector that produces vacuum in the tank. The hose are then connected to an approved exhaust fan. Standard length 2,5 metres. Contact us for custom lengths.



### 05-00009 Fuel drainer for trucks and busses

The fuel suction unit is intended, approved and EX classed for ethanol, diesel and petrol. It is equipped with 4 wheels but it can also be handled using a pallet lifter or a fork lifter. The fuel suction unit is made from stainless steel. Its capacity is 630 liters and it weighs 145 kg when empty. The fuel suction unit is powered by a pneumatic diaphragm pump that drains and fills with 20 lit/min. An overflow protection device automatically breaks the air supply to the pump if the fuel level in the fuel suction unit is too high.

The fuel suction unit is equipped with a bleed hose fitted with a flame guard, which is connected to the vehicle exhaust extraction system when draining vehicles to achieve odorless fuel handling.

The unit is supplied with three suction and filler adapters.

1. L1054-1 Fuel refill 15 litres/min
2. 05-00009-002 Fuel hose 1/2", 3 m
3. 05-00009-003 Adapter Tema 1800 – Parker NS

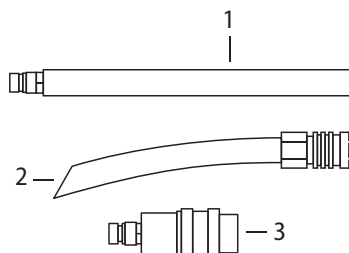

630L



# Hydraulic tools for trucks

## 03-00025 Dismantling set, Volvo/Renault/DAF floating brake disc

A brand new tool that really helps when Volvo's floating brake discs need to be removed.

The disc brake is pressed out one cylinder at a time. This is very efficient and saves a great deal of time in the workshop. Pressing at extreme pressure using a workshop press on sensitive

metal parts or cutting off the thick brake disc are both noisy and dangerous operations.

The tool consists of two special cylinders and a control valve for crosswise pressing. Pressing out the disc in this way only takes a few minutes.



## 03-00007 Universal set for Kingpin

This set is designed to cover most Kingpins on the market, also the conical types. It's used with a unique 32 ton hydraulic cylinder designed with punching capability. This function makes it possible to hammer on the cylinder (with punch adaptor 1086-6 fitted) during maximum pressure. The combination of high pressure and vibrations are very efficient and often crucial for a successful result. With this tool, heating or heavy lifting in the shop press is no longer needed. The compact design makes it possible to do the job also on buses where the access normally is limited.



### Parts in the set:

03-00003-001	Press block	03-00006-005	Press pipe 42 mm
03-00006-001	Press axle 250 mm Ø31 mm	03-00006-006	Press pipe 130 mm
03-00006-002	Press axle 140 mm Ø31 mm	03-00006-007	Press pipe 42 mm
03-00006-003	Adaptor plate	03-00006-008	Press socket 65 mm
03-00006-004	Press pipe 145 mm	1086-6	Punching socket M22x2,5

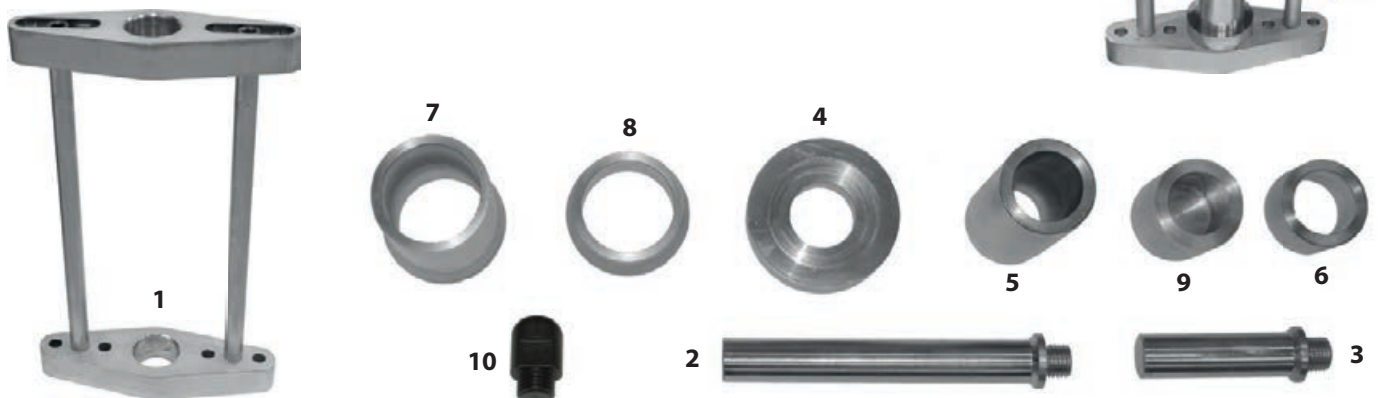

### 03-00006-022 Dismounting collar Volvo Kingpin

Is used with universal set 03-00007 for pressing out Volvo kingpins with locknuts underneath.

The collar locks the bearing so that only the kingpin is pressed out.



### 03-00006-023 Mounting plate Volvo Kingpin

Is used with universal set 03-00007 for pressing in Volvo kingpins with locknuts underneath.

The plate guides the kingpin into position when pressing/mounting.



### 03-00006-024 Press socket Scania Kingpin

Is used with universal set 03-00007 for pressing out Scania conical kingpins.



### 03-00030 Hydraulic ball joint puller

Press clamp for dismounting steering joints on trucks/buses and ball-joints on light commercial vehicles.

The clamp is special designed to fit on most steering axles and ball-joints on light commercial, vehicles, heavy trucks and buses on the market. Moulded with special steel to withstand greater force.

**NEW!**

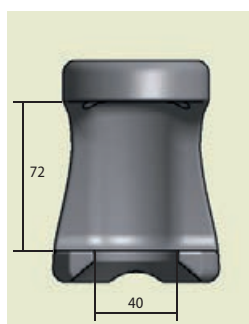

#### Parts in the set:

1. 03-00014-001 – Steering joint puller
2. 03-00015 – Hydraulic cylinder 8,5 ton

### RES4031

Carriage beam M22/M24. A specially designed adaptor for pulling out the bolts in digging and lifting arms. The beam can be used with the following cylinders; 1090-01, 1090-02-WAL and 1090-05/03-00028.

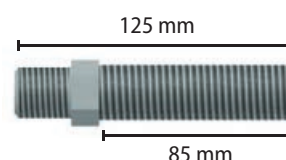

## 03-00016 Hub puller set for heavy duty trucks/busses, 8/275, 10/335

The tool is flexible and fits heavy trucks/busses with 8 bolt 275 mm and 10 bolt 335 mm. The tool is used with 32 tons hydraulic cylinder 1090-05/03-00028 and 03-00026 (45 ton).

The robust design allows also punching with a hammer on the cylinder during max press (45 ton). This function makes it possible to press out hubs also with unit wheel bearings from straight axles. The press plate with thread is also used as a part in the press block no 03-00003-001.

### Parts in the set:

1. 2 pcs 03-00016-001 – Press fot for hub puller
2. 03-00006-001 – Press axle 250 mm Ø31mm
3. 03-00006-002 – Press axle 140 mm Ø31mm
4. 03-00006-020 – Press axle 50 mm Ø31mm
5. 03-00006-021 – Press plate
6. 03-00003-002 – Plate with thread
7. 4 pcs 03-00003-005 – Screw M22x60 12.9, ob, hexsocket
8. 1086-6 – Punch socket



## 03-00006-025 Extender for hub puller

For use with hub puller 03-00016 on axels with hub reduction/gear inside the hub (4 pcs needed). For example Scania.



## 03-00022 Hub puller for low loader trailers with 10/225 hubs

Extension set to 03-00016 for removal of 225 mm hubs and 10 bolts, hydraulic cylinder 1090-05/03-00028 (32 ton) and 03-00026 (45 ton) is used with the set. The heavy-duty design supports a full 45 ton pressure and hammer strokes in the direction of pressure (on the cylinder) during removal. This makes it also possible to remove hubs with unit bearings on straight axles.

### Parts in the set:

1. 2 x 03-00022-001 - Plate
2. 4 x 03-00022-002 - Arm
3. 03-00022-003 - Thrust washer SAF Ø 73 mm
4. 8 x 03-00003-005 - Screws M22x60 12.9.

**NEW!**

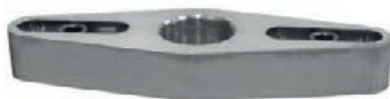

## 03-00003-002 Plate with thread for press block (not included)

Included in universal set 03-00007.



**NEW!**

## 03-00027-32T/ 03-00027-45T Puller set for hubs without wheel bolt flanges

The set makes it possible to efficiently remove rusted bearings with external hubs from straight axles. Developed for Volvo FL, MAN TGA, TGS, TGX, Mercedes Atego, Actros, Renault Kerax, Magnum, Midlum and Premium, fits also other brands with the same bolt dia. The set is used with hydraulic cylinder 1090-05/03-00028 (32 ton) or 03-00026 (45 ton).

### Parts in the set:

03-00027-32T	03-00027-45T
1. 03-00027-010	1. 03-00027-010
2. 03-00027-012	2. 03-00027-012
3. 03-00027-002 (M24)	3. 03-00027-003 (M30)
4. 1086-6	

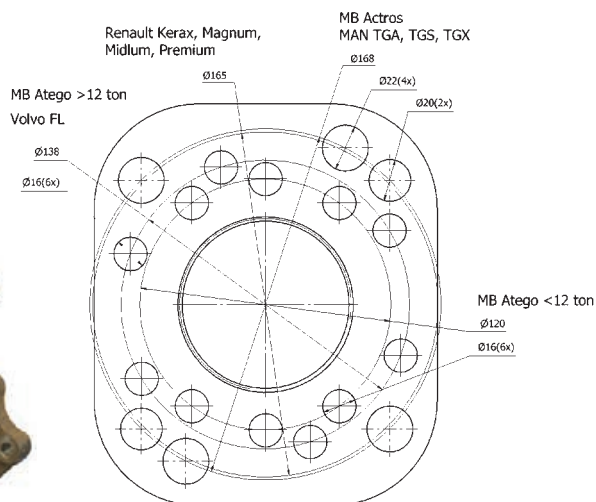
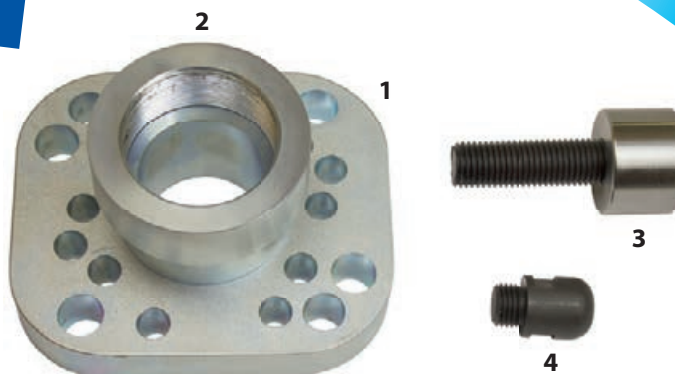

## 03-00008 Spring bolt set (Scania)

A tool set for quick dismounting of the spring bushing bolts. The job is done directly on the truck with a minimum of part dismounting. The set is used with the threaded plate 03-00003-002 from the press block 03-00003-001 and the 32 ton hydraulic cylinder 1090-05/03-00028 (none of these are included), also designed for punching. The combination of the high pressure and vibrations are very efficient and often crucial for a successful result when pressing out the rusted bolts.



### Parts in the set:

- 03-00004-001 – Press block
- 03-00006-009 – Press axle 115 mm Ø29 mm
- 03-00006-010 – Press axle 100 mm Ø29 mm
- 03-00006-011 – Press pipe 60 mm Ø54 mm
- 1086-6 – Punching socket M22x2,5
- 4 pcs 03-00003-005 - Screw M22x60 12.9 hex

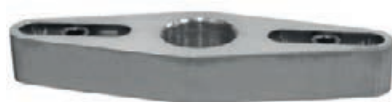

## 03-00003-002 Plate with thread for press block (not included)

Included in universal set 03-00007.

### 03-00020 Wheel bearing set (Unit) Scania

With this set a wheel bearing is replaced quick and easy directly at the vehicle, no need to go to the shop press. The set is used with 32 ton hydraulic cylinder 1090-05/03-00028 and hub puller set 03-00016. Parts for allowing hammer punching during max pressure are also included.

**Parts in the set:**

- 1. 03-00006-026 Press socket 65 mm
- 2. 03-00020-001 Press plate Scania unitlager
- 3. 03-00020-002 Press plate Scania unitlager
- 4. 03-00020-003 Protection socket Scania unitlager
- 5. 1091-17-M22 Punching nut M22
- 6. RES4025 Flange nut M22
- 7. RES4034 Carriage beam M22, 500 mm

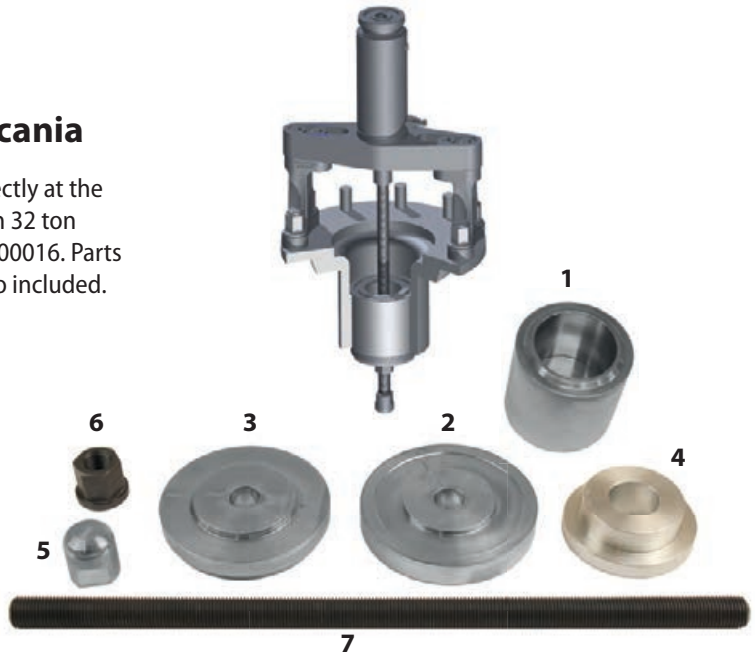

### 03-00009 Spring bushing set, universal

The spring and shackle bracket bushings (44–64 mm) are quick and easy replaced. No heating or lifting in the shop press is needed when working with this set. It's used with the 32 ton cylinder 1090-05/03-00028 (not included).

**Parts in the set:**

- 1. 03-00006-006 – Press pipe 130 mm
- 2. 03-00006-007 – Press pipe 42 mm
- 3. 03-00006-014 – Press plate Ø63 mm
- 4. 03-00006-015 – Press plate Ø50 mm
- 5. 03-00006-016 – Press plate Ø44 mm
- 6. 03-00006-017 – Press plate Ø63 mm
- 7. 03-00006-018 – Press plate Ø57 mm
- 8. RES4024 – Flange nut M18
- 9. RES4026 – Carriage beam M18, 250 mm
- 10. RES4025 – Flange nut M22
- 11. RES4027 – Carriage beam M22, 250 mm
- 12. 1091-17-M22 – Punching nut M22

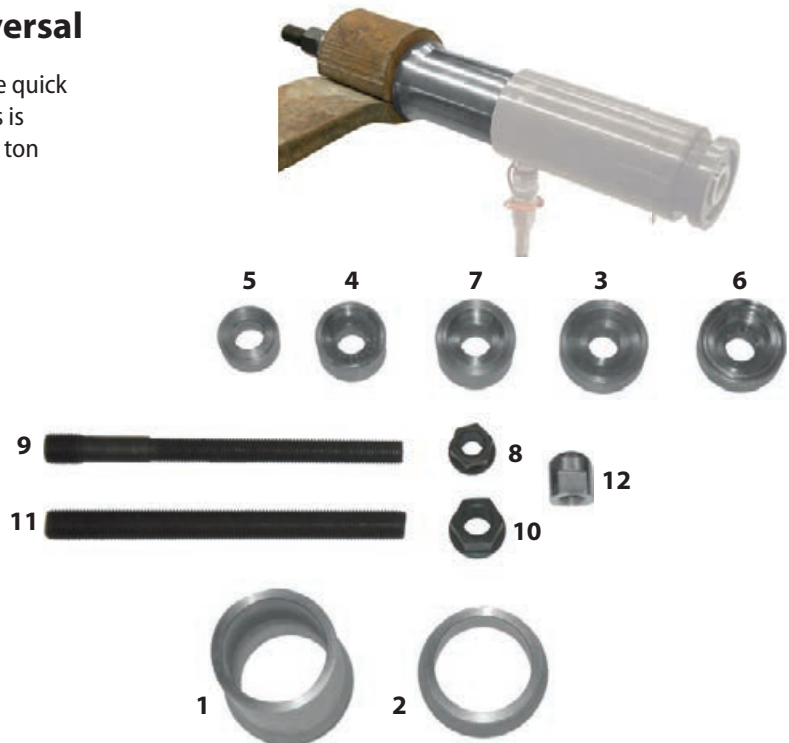

### 03-00013 Bushing set SAF-axle, 150 mm

A set for quick and easy replacement of the large 150 mm bushing in SAF axles. The set is used with the 32 ton hydraulic cylinder 1090-05/03-00028 (not included).

**Parts in the set:**

- 1. 03-00013-001 – Mounting ring 45mm
- 2. 03-00013-002 – De/mounting ring 20mm
- 3. 03-00013-003 – De/mounting plate
- 4. 1091-17-02 – Press plate
- 5. 1091-17-03 – Press pipe
- 6. RES4034 – Carriage beam M22, 500 mm

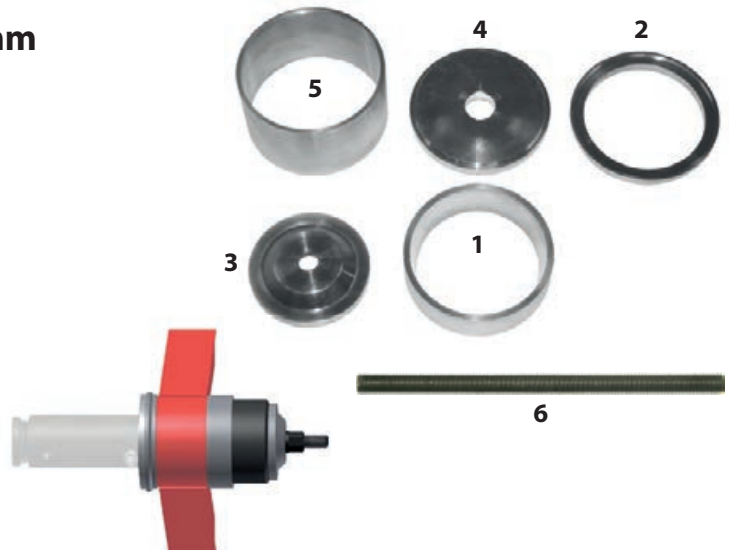

## 1091-24-001 Universal set for replacing wheel bolts on commercial vehicles

Set for quick and easy replacing of wheel bolts on commercial vehicles. The wheel bolts are replaced without any hammering or physical effort. The set covers trucks from, Volvo, Scania, DAF and Renault. And most of the European truck and trailer fleet. BPW, ROR, SAF, SMB/Frauhof.

Used with (but not included in the set) cylinder 1090-03 or 03-00015 and press block 1090-55-B.

Est.time: <30 sec/bolt.

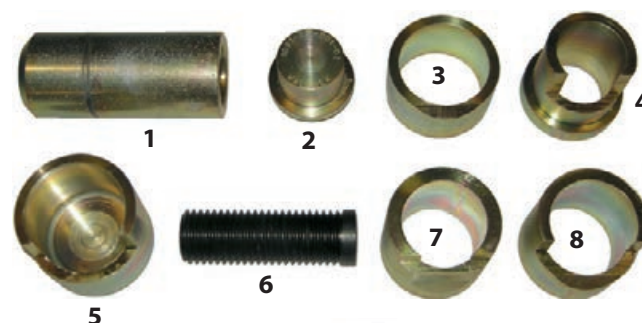

### Parts in the set:

1. 1091-24-001-01 - Mounting socket
2. 1091-24-001-02 - Holder
3. 1091-24-001-03 - Dismounting pipe Volvo big, SMB
4. 1091-24-001-04 - Dismounting pipe Volvo small
5. 1091-24-001-05 - Dismounting socket Scania
6. 1091-24-001-06 - Adjustable press rod 76 mm, M24
7. 1091-24-001-07 - Dismounting pipe SAF
8. 1091-24-001-08 - Dismounting pipe BPW, ROR



## 03-00012 Add on set for brake anchor bolt

For use with wheel bolt set no 1091-24-001, press block 1090-55-B and hydraulic cylinder 1090-03 alt. 03-00015 (not included) for quick and easy replacement of the anchor bolt and its bushing.

### Parts in the set:

1. 03-00012-001 - Press pipe
2. 03-00012-002 - Press socket
3. 03-00012-003 - Press socket



## 03-00005-001 Automatic brake adjuster puller/steering joint on trailers

Used for pressing out rusted and stuck axles from the brake adjuster.

Fits most types on the market from Haldex and BPW.

The tool is used with a 8,5 ton hydraulic cylinder 03-00015 (not included).

The design allows good access even in narrow areas on the vehicle.



## 03-00006-012 Adaptor for VBG drawbar bolts

The adaptor is used with the Kingpin set 03-00007 for pressing out the bushing bolts on VBG drawbars (not hex bolts). The bolt is pressed out in a similar way as the kingpin but with the press frame in a horizontal position.



### 03-00017 Press block set for pulling out truck/trailer connectors with VBG 55 mm axle



With this set the complete pulling connector is pulled out from its holder when maintenance is needed. This solution saves a lot of time and efforts during dismounting. It is used with one of the following cylinders; 1090-02 or 1090-01.



### 03-00010 Bushing set for drawbars

This set is primarily designed for VBG bushings and drawbars but is also universal. The bushing is replaced with 32 ton hydraulic cylinder 1090-05/03-00028 (not included) with the unique punching function directly on the drawbar.

The bushing is replaced quickly with no need of heating.

#### Parts in the set:

1. 03-00006-006 – Press pipe 130 mm
2. 03-00006-007 – Press pipe 42 mm
3. 03-00006-013 – Press plate Ø59 mm
4. RES4025 – Flange nut M22
5. RES4027 – Carriage beam M22, 250mm
6. 1091-17-M22 – Punching nut M22

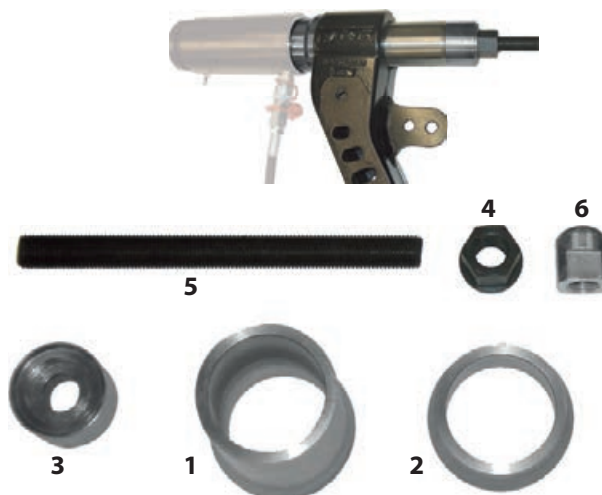

### 03-00021-001 Universal basic set for commercial truck and bus garages

The set comes with tools for efficient jobs on straight and conic king-pins, bushings in spring and draw bars and large lock rings. Dismounting tools for steering joints, wheel hubs, slack adjusters and VBG draw bar bolts. A heavy duty tool cart with hangers and a working surface on top comes with this basic set.

#### Parts in the set:

- |                      |              |
|----------------------|--------------|
| 03-00028             | 03-00006-012 |
| RES4024              | 03-00006-013 |
| RES4026              | 03-00006-014 |
| 03-00007             | 03-00006-015 |
| 03-00014-001         | 03-00006-016 |
| 03-00015             | 03-00006-017 |
| 03-00005-001         | 03-00006-018 |
| 03-00016-001 – 2 pcs | 01-00004     |
| 03-00006-020         | 1090-50      |
| 03-00006-021         | 1090-53      |
| 03-00003-005 – 2 pcs |              |

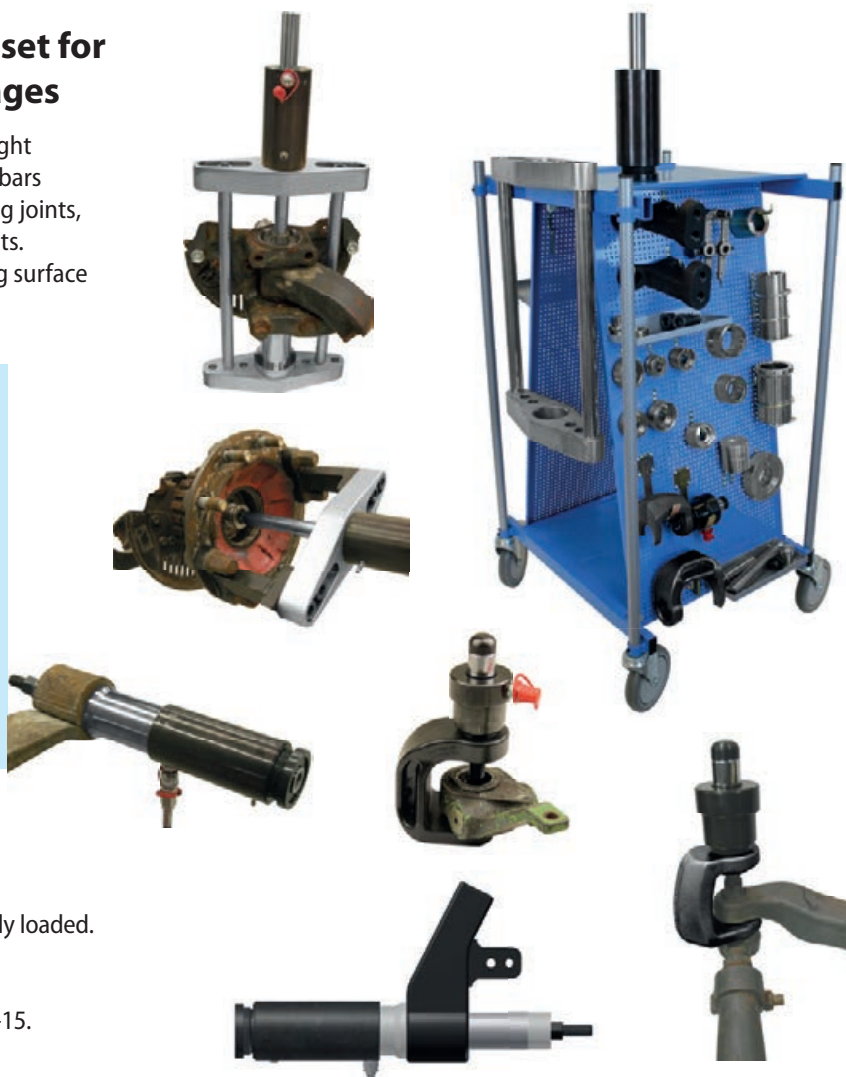

### 1090-50 Tool cart

A sturdy construction with a large working surface. The large wheels makes it easy to transport also fully loaded. Three different shelf/hook sets is available:  
 1090-51 Tool holder for 1090-20.  
 1090-52 Tool holder for 1090-30, 1090-25 or 1090-15.  
 1090-53 Tool holder for trucks.









# WALLMEK í Kungälv AB

Bultgatan 18, SE-442 40 Kungälv, Sweden  
Phone +46 (0)303 585 80. Fax +46 (0)303 942 46  
info@wallmek.se • www.wallmek.se



DISTRIBUTOR