



2016 Application Guide | LHD

Wiper Blades
 Wischerblätter
 Balais d'essuie-glace
 Escobillas para limpiaparabrisas
 Spazzole per tergicristalli
 Escovas
 Wisserbladen
 Vindusviskerblader
 Viskerblade
 Torkarblad
 Pióra wycieraczek
 Щётки стеклоочистителя
 Μάκτρα υαλοκαθαριστήρων
 Þurrkublöð
 stíracích list
 pyyhinsulat
 Klaasipuhastiharjad
 Ştergătoare
 metlice brisalnikov
 Silecek Bıçakları





YOUR PERFECT SOLUTION FOR **ORIGINAL QUALITY FIT, FORM & FUNCTION**

Introducing the TRICO Factory Replacement Centre, featuring the complete wiper blade line for the aftermarket: **TRICO Exact Fit.**

BEAM



CONVENTIONAL



HYBRID



REAR



- **Original style fit, form and function** - whatever the application
- **One programme covers it all** - easy to stock, easy to sell
- **Full range programme** offering more than 98% vehicle coverage
- **Quick & easy direct installation** with no changing or fitting loose adaptors

TRICO Exact Fit®

World leaders in screen wiping technology since 1917.

Trico were the first to commercially manufacture the wiper blade way back in 1917 - and for almost 100 years since, we haven't stopped developing and innovating to keep our products at the forefront of performance and safety. That's why today, **we're trusted to deliver OE products to vehicle manufacturers worldwide.**

Today, we apply our **unrivalled specialist expertise** to designing and manufacturing complete wiper systems, wiper blades, wiper arms, wiper linkages, wiper motors, electronics and vision modules for the global automotive industry. And **with safety as our priority**, we continue to **develop ever more effective systems** for giving drivers a clear view of the road ahead.



INDEX

PAGE(S)

Range Overviews.....	2 - 19
Layout Guide.....	20
Guide To Symbols.....	20
Application Guide.....	21- 86
Image Buyers Guide.....	87 - 120
Fitting Instructions.....	121 - 131
Notes.....	132

DE Original Fit Beam-Wischerblätter

- Beam-Design im europäischen Stil mit Ein-Punkt-Verbindungssystem
- Einfache, direkte Montage an allen Beam-Wischerarmen – keine Anpassung oder Kürzung von losen Verbindungsteilen notwendig
- Die einzigartigen Verbinder von Trico passen an 3 verschiedene Wischerarmtypen, was die Anzahl der zu führenden Lagerposten verringert
- Hergestellt in unserem OE-Werk nach Spezifikationen der Erstausrüster

1. Asymmetrischer Spoiler - Windabweisung für eine bessere Wischleistung, auch bei hohen Geschwindigkeiten
2. Direct-Fit-Verbinder - Lässt sich direkt auf den Wischam aufstecken, ohne dass man lose Teile entfernen oder hinzufügen muss
3. Gummi nach Trico-Rezeptur - Einzigartige Originalteile nach Zweikomponenten Rezeptur mit Graphitbeschichtung für eine längere Produktlebensdauer
4. Doppelteilnut-Führung aus Stahl - Doppelnutführung aus gerolltem Stahl sorgt für eine gleichmäßige Druckverteilung und verringert den Lärmpegel

FR Balai d'essuie-glace à profil aérodynamique - montage d'origine

- Balai plat de style européen avec profil aérodynamique
- Montage simple et direct sur tous les types de bras d'essuie-glace à balai plat – aucun changement ni aucune installation d'adaptateurs indépendants
- Les connecteurs Trico sont uniques : un même connecteur peut s'adapter à 3 types de bras, ce qui réduit le nombre de références requises
- Fabriqués dans notre usine de production de pièces d'origine conformément aux spécifications des pièces d'origine

1. Défecteur asymétrique - Permet au balai de résister au soulèvement sous l'action du vent pour de meilleures performances, même à grande vitesse
2. Connecteur direct - Se monte directement au bras de l'essuie-glace sans ajout ou retrait de pièces indépendantes
3. Caoutchouc de formulation unique Trico - Bi-matière avec revêtement graphite pour durée d'utilisation prolongée
4. Vertèbre en acier double rail - La conception en acier laminé double rail assure une répartition homogène de la pression et réduit le bruit

ES Escobillas flexibles de instalación original

- Diseño flexible de estilo europeo y sistema de acoplamiento de un solo punto
- Instalación simple y directa en todos los tipos de brazos limpiaparabrisas flexibles, sin necesidad de sustituir ni ajustar adaptadores flojos
- Los conectores exclusivos de Trico se ajustan a hasta 3 tipos de brazos, de forma que se reduce la cantidad de códigos de almacén (Stock-keeping unit, SKU) necesarios
- Fabricadas en nuestra planta de equipos originales (EO) según las especificaciones de equipos originales

1. Alerón asimétrico - Resiste la elevación por el efecto del viento para proporcionar un rendimiento mejor, incluso a alta velocidad.
2. Conector de instalación directa - Se instala directamente en el brazo limpiaparabrisas sin necesidad de añadir ni quitar piezas sueltas.
3. Goma formulada de Trico - Formulación doble y exclusiva de materiales de los equipos originales (EO) con revestimiento de grafito que prolonga la vida útil.
4. Chaveta doble de acero de carril - El diseño doble de acero laminado de carril proporciona una distribución uniforme de la presión y reduce el ruido.

IT Tergicristalli a spazzola piatta originale

- Spazzole dal design europeo con sistema di attacco a punto singolo
- Montaggio semplice e diretto in tutti i tipi di bracci di tergicristalli a spazzola piatta – nessuna necessità di cambiare o montare adattatori sfusi
- I caratteristici connettori Trico si adattano a 3 tipi di bracci con lo stesso connettore, riducendo il numero di articoli che è necessario tenere a magazzino.
- Prodotto nel nostro stabilimento OE secondo le specifiche dei componenti originali.

1. Spoiler asimmetrico - Resiste al carico del vento per prestazioni migliori anche alle alte velocità
2. Connettore per montaggio diretto - Si innesta direttamente sul braccio del tergicristallo senza aggiungere o rimuovere parti staccabili
3. Gomma dalla formulazione Trico esclusiva - Formulazione OE esclusiva in materiale doppio con rivestimento in grafite per una durata più elevata
4. Scanalatura in acciaio a doppio binario - La struttura in acciaio laminato a doppio binario offre una distribuzione uniforme della pressione e riduce il rumore

PT Escovas limpa-vidros planas de encaixe originais

- Design de escovas planas de estilo europeu com sistema de acoplamento de ponto único
- Encaixe simples e direto em todos os tipos de braços de escovas limpa-vidros, sem necessidade de trocar ou ajustar adaptadores soltos
- Os conetores Trico exclusivos permitem encaixar até 3 tipos de braços com o mesmo conetor, reduzindo o número de unidades de manutenção de stock (SKU) necessárias
- Fabricadas na nossa fábrica de equipamento original de acordo com as especificações de equipamento original

1. Spoiler assimétrico - Resiste à elevação pelo vento para oferecer um desempenho superior mesmo a alta velocidade
2. Conetor de encaixe direto - Encaixa diretamente no braço das escovas limpa-vidros sem necessidade de inserir ou remover peças soltas
3. Borracha formulada Trico - Formulção exclusiva de material duplo original com revestimento de grafite para uma vida útil prolongada
4. Veio de aço com estria dupla - O design em aço laminado de estria dupla proporciona uma distribuição uniforme da pressão e minimiza o ruído

NL Originale draagbladwissers

- Bladontwerp in Europese stijl met enkelvoudig aansluitingssysteem
- Eenvoudig en rechtstreeks aan te brengen op alle bladwisserarmsoorten - u hoeft geen losse adapters te verwisselen of aan te brengen
- Op de unieke Trico-connectors kunnen tot 3 armsoorten met dezelfde connector worden aangebracht, zodat er minder SKU's nodig zijn
- Geproduceerd in onze OE-fabriek in overeenstemming met de specificaties van de oorspronkelijke apparatuur (Originale Equipment, OE)

1. Asymmetrische spoiler - Weerstaat optillen door de wind voor verbeterde prestaties, ook op hoge snelheid
2. Direct aan te brengen connector - Past rechtstreeks op de ruitwisserarm zonder toevoeging of verwijdering van losse onderdelen
3. Trico geformuleerd rubber - Uniek, uit twee materialen bestaande OE-formulering met grafit-coating voor een langere levensduur
4. Stalen spiebaan met twinrail - Op twinrail rollende stalen ontwerp geeft evenredige drukverdeling en verlaagt het geluidsniveau

NO Bomblader av original type

- Vindusviskerdesign i europeisk stil med system med kun ett koblingspunkt
- Enkel, direkte montering på alle typer vindusviskeramer – ikke behov for å skifte ut eller montere ekstra adaptere
- Unike Trico-koblinger kan montere opptil tre armer med den samme koblingen, hvilket reduserer antallet nødvendige SKU-er
- Produseres ved OE-anlegget vår etter spesifikasjonene for originalt utstyr

1. Asymmetrisk spoiler - Reduserer vindbelastningen som gir bedre vaskeløst, jevnere og høy hastighet
2. Kobling for direkte montering - Kobles direkte til viskeramen uten nye deler eller fjerning av løse deler
3. Gummi av Trico-formel - Unik OE-sammensetning av dobbelt materiale med grafit-belegg som gir lengre levetid
4. Dobbel stålskinne - Dobbeltskinne i valset stål gir jevn trykkfordeling og reduserer støy

DK Originalmonterede flatblade

- Europeisk flat-design med et-punktskoblingsystem
- Simple, direkte montering på alle flatblade-viskeramer – ingen udskifning eller montering af løse adaptere
- Unikke Trico-forbindelsesstykker monterer op til 3 armtyper med samme forbindelsesstykke, hvilket reducerer antallet af nødvendige varelager
- Fremstillet på vores originaludstyrsfabrik i henhold til originaludstyrspecifikationer

1. Asymmetrisk spoiler - Modstår vindloft, hvilket giver bedre resultater, også ved høj hastighed
2. Beslag til direkte montering - Passer direkte på vindusviskeren uden at tilføje eller fjerne løse dele
3. Trico-udformet gummi - Unik udformning med OE-dobbelmateriale og grafitbelegning der forøger holdbarheden
4. Stålfugleline med dobbelt skinne - Stålfugleline med dobbelt skinne fordeler trykket bedre og støjer mindre

SE Bygglösa torkkarblad med originalpassform

- Bygglösa design i europeisk stil med enpunktskopplingsystem
- Enkel och direkt passning till alla typer av bygglösa torkkarmar – inget byte eller inpassning av lösa adapter
- De unika Trico-fästena passar upp till tre armtyper med samma fäste, vilket minskar antalet nödvändiga lagerplatsenheter
- Tillverkas i vår originaldelsfabrik enligt specifikationer för originalutrustning

1. Asymmetrisk spoiler - Står emot vindlyft för förbättrad prestanda även vid hög hastighet
2. Direktpassande anslutare - Monteras direkt på torkkarbladet utan montering eller borttagning av lösa delar
3. Trico-utformat gummi - Unik originaldelsutformning i dubbelmaterial med grafit- beläggning för längre tjänstlev
4. Stålsplina med dubbla skenor - Utformning med dubbla skenor ger jämn tryckfördelning och minskar ljud

PL Wycieraczki płaskie z oryginalnym mocowaniem

- Wycieraczki typu europejskiego z jednopunktowym mocowaniem
- Proste mocowanie bezpośrednie na wszelkiego typu ramionach wycieraczek płaskich, bez konieczności zmiany i mocowania luznych złączek
- Jedne w swoim rodzaju złączki Trico pasują aż do 3 rodzajów ramion, co pozwala zmniejszyć liczbę SKU
- Wyprodukowano w naszej fabryce oryginalnego sprzętu zgodnie ze specyfikacjami oryginalnego sprzętu

1. Spoiler asymetryczny - Zapobiega unoszeniu się wycieraczki nawet przy dużych prędkościach, gwarantując wyższą skuteczność wycierania
2. Złączka bezpośrednia - Umożliwia mocowanie bezpośrednio do ramion wycieraczek bez konieczności dodawania lub usuwania luznych elementów
3. Formowanie gumy w technologii Trico - Originalna wskaźnikowa mieszanka gumy z dodatkową powłoką grafitową, która przedłuża żywotność wycieraczek
4. Podwojony rdzeń stalowy - Podwojony rdzeń wykonany ze stali walcowanej gwarantuje równomierne rozłożenie nacisku i cichą pracę wycieraczki

RU Бескарнасные щетки Original Fit

- Бескарнасные щетки в евроисполнении с одноточечной соединительной муфтой
- Простая, легкая установка на все типы рычагов – не нужно заменять или устанавливать свободные адаптеры
- Уникальные соединения Trico можно использовать с 3 типами рычагов, что снижает количество необходимых номенклатурных позиций
- Изготавливаются на собственном заводе по спецификациям оригинального оборудования

1. Асимметричный спойлер - Нейтрализует подъемную силу ветра, что обеспечивает повышенную эффективность даже на высоких скоростях
2. Соединение с предусмотренным адаптером - Устанавливается непосредственно на рычаг стеклоочистителя, нет необходимости устанавливать или снимать отдельные детали
3. Состав каучука от компании Trico - Уникальный двойной состав материала с графитовым покрытием обеспечивает длительный срок службы
4. Стальное шплицевое соединение с двумя шпонками - Конструкция из прокатной стали с двумя шпонками обеспечивает равномерное распределение давления и снижает уровень шума

GR Μονοκόμματα μάκτρα τυπικού εξοπλισμού

- Μονοκόμματα σχεδιασμός ευρωπαϊκού stύλ, με σύστημα μονοκόμματος τύπου
- Απλή, άμεση τοποθέτηση σε όλους τους τύπους βραχίονα υαλοκαθαριστήρα – χωρίς αλλαγές ή τοποθέτηση χαλαρών προσαρμογών
- Οι μοναδικές σύνδεσεις Trico εφαρμόζονται σε έως και 3 τύπους βραχίονα με τον ίδιο σύνδεσμο, μειώνοντας τον αριθμό των απαιτούμενων SKU
- Κατασκευάζονται στις εγκαταστάσεις κατασκευής προϊόντων για κατασκευαστές πρωτότυπου εξοπλισμού, σύμφωνα με τις προδιαγραφές των κατασκευαστών

1. Ασύμμετρο σπόιλερ - Με αντίσταση στην ανύψωση από τον αέρα για βελτιωμένη απόδοση, ακόμα και με υψηλή ταχύτητα
2. Σύνδεσμος άμεσης τοποθέτησης - Τοποθετείται απευθείας στο βραχίονα του υαλοκαθαριστήρα χωρίς την προσθήκη ή την αφαίρεση χαλαρών εξαρτημάτων
3. Καυστικό μορφοποιημένο από την Trico - Μοναδική σύνθεση πρωτότυπου εξοπλισμού διπλού υαλοκαθαριστήρα με επίστρωση από γραφίτη για παρατεταμένη διάρκεια χρήσης
4. Άξονας με διπλή ράβδο από χάλυβα - Η σχεδίαση με διπλή ράβδο από ελασμένο χάλυβα αποδίδει ομοιόμορφη κατανομή πίεσης και μειώνει το θόρυβο

IS Sveigð þurrkublöð fyrir fyrirliggjandi festingar

- Þurrkublöð í evrópskum stíl með eins punkts tengikerfi
- Einföld og bein uppsetning á allar gerðir arma – án þess að skipta þurfi um eða setja upp laus millistykki
- Með hinum einstöku Trico-tengjum má setja þurrkublöð á allt að þrjár gerðir þurruarma með sama tengingu, sem minnkur þörfina á lagerbirgðum
- Framleidd í verksmiðju okkar samkvæmt tæknilyngingu fyrir upprunalegan búnað

1. Ósamhverf vindskelið - Vinnur gegn vindmótstöðu til að bæta frammiðbúna, jafnvel á miklum hraða
2. Millillíbalusta tengi - Fellur beint á þurruarminn án þess að bæta þurfi við eða fjarlægja lausa hluta
3. Mótað gúmmi frá Trico - Upprunalegur búnaður úr tvískiptu efni sem er mótað og grafituðað til að lengja notkunartíma
4. Stálrill með tvöföldu ríði - Tvöföldur stálrill tryggir jafnari dreifingu þrýstings og dregur úr hávaða

CZ Originální lišty bezramkových stěračů

- Evropský design lišty se systémem spoje v jednom místě
- Jednoduché a přímé upevnění ke všem typům nosičů bezramkových stěračů – není potřeba nic měnit nebo využívat volné redukce
- Jediné spočky Trico umožňují osazení až na 3 typy nosičů při využití stejné spočky, což snižuje počet nezbytných skladových jednotek
- Vyráběno v našem závodě podle specifikací vyhovujících originálnímu vybavení

1. Asymetrický spoiler - Odolný vůči vztlaku větru, čímž zvyšuje výkonnost při vysoké rychlosti
2. Přesné pasující konektor - Pasuje přesně do ramena stěrače bez nutnosti přidat nebo odstranit nepříjemné části
3. Guma vytvořená společností Trico - Originální díly ze speciálního dvoosložkového materiálu s grafitovým potahem, který prodlužuje životnost výrobku
4. Dvouarmý kovový držák - Ocelová konstrukce s dvěma rameny a zaoblený tvar umožňují rovnoměrné rozložení tlaku a snižují hluknost

FI Rungottamat Original Fit -pyyhkijänsalat

- Eurooppalaistylinen rungoton sulkanmalli, jossa on yhden pisteen kiinnitysjärjestelmä
- Mutkaton, suora kiinnitys kaikenlaisiin pyyhivinvarsin, ei löysästi istuvien sovittimien vaihtamista ja asentamista
- Ainutlaatuista Trico-liittimet soveltuvat kolmentyyppisiin varsin, niin että tarvitaan pienempi määrä tuotekoodoja
- Valmistettu alkupeiristehtaassamme alkupeiräisen valmistajan tietojen mukaisesti

1. Epäsymmetrinen ilmanohjain - Ehkäisee tuulen nostetta parantaen suuntuskykyä suorasinkin ajoneuvuksissa
2. Suoraan asennettava liitin - Asennetaan suoraan pyyhkijän varteen ilman irto-osien lisäämistä tai poistamista
3. Tricoon kehittelämä kumi - Ainutlaatuinen kahden materiaalin OE-muotoilla grafitipinnoitella pidentää käyttöikä
4. Kahden kiskon teräsriihä - Kahden kiskon valssattu teräsmuotoilu jalkaa paineen tasaisesti ja vähentää äänekyyttä

EE Original Fit raamiga harjad

- Euroopa stiilis raamikonstruktsioon koos ühepunktilise ühendussüsteemiga
- Lihtne, vahetu ühendamine kõikide raamiga klaasipuhasti hoobadega – puudub vajadus lahiste adaptreite asendamiseks või sobitamiseks
- Universaalseid Trico liitmike puhul on võimalik ühendada sama liitmikuga kuni 3 hoovatüüpi
- Valmistatud meie OE tehases originaalseid varuosade spetsifikatsioonide alusel

1. Asümmeetriline spoiler - Takistab tuuletõust ja parandab töövõimet isegi kõrge kiiruse
2. Direct Fit liitmik - Sobib klaasipuhasti hoovaga lahiste osade lisamise või eemaldamiseks
3. Trico spetsiaalse koostise kummi - Unikaalne grafitkattega kahest materjalist koosnev OE segu kasutusea pikendamiseks
4. Twin Rail Steel Spline - Kahe valtersest latiga konstruktsioon tagab ühtlase survejaotuse ja vähendab müra

RO Lame fără cadru cu montare originală

- Design fără cadru în stil european cu sistem de cuplare intr-un singur punct
- Montare simplă, directă pe toate tipurile de brațe de ștergător fără cadru - fără a fi necesară schimbarea sau fixarea adaptoarelor cu joc
- Conectorii unici Trico permit montarea a până la 3 tipuri de brațe cu același conector, reducând numărul de SKU-uri necesare
- Fabricate în fabrica noastră de echipamente originale conform specificațiilor privind echipamentele originale

1. Spoiler asimetric - Rezistă la poranță pentru o performanță îmbunătățită chiar și la viteze mari
2. Conector cu montare directă - Se fixează direct pe brațul de ștergător fără a adăuga sau a îndepărta piesele de tranșe
3. Cauciuc formulat Trico - Formulare de tip echipament original cu material dublu, unic cu strat de acoperire din grafit pentru o durată de funcționare prelungită
4. Pană de ghidare, din oțel, cu șină dublă - Designul din oțel laminat, cu șină dublă, oferă distribuția uniformă a presiunii și reduce zgomotul

SI Zdržljive ploske metlice

- Metlica z evropsko zasnovno in enotockovnim spojinim sistemom
- Enostavna, neposredna pritrditve na vse tipe ročic za brisanje – brez zamenjave ali namescanja dodatnih nastavkov
- Edinstvene priključki Trico omogočajo, da pritrditve 3 ročice za brisanje z istim priključkom, kar zmanjša potrebne inventarne številke
- Proizvedeno v našem obratu OE po specifikacijah originalne opreme

1. Asimetrični spojler - Zmanjšuje vetri upor za boljšo učinkovitost tudi pri višjih hitrostih
2. Priključek za neposredno namesitev - Namesitev neposredno na nosilec brisalca brez dodajanja ali odstranjevanja neprijetnih delov
3. Sestavljena guma Trico - Edinstvena sestava kot originalna oprema iz dvojnega materiala z grafitno prevleko za daljšo življenjsko dobo
4. Jeklena letev z dvojnimi vodilom - Zavita zasnovna jekla z dvojnimi vodilom zagotavlja enakomerno porazdelitev pritiska in zmanjšuje hrup

TRICO Exact Fit[®]



Original Quality Fit, Form & Function. 

Original Fit Beam Blades

- European style beam design with single point coupler system
- Simple, direct fitment to all beam wiper arm types - no changing or fitting loose adaptors
- Unique Trico connectors fit up to 3 arm types with the same connector, reducing number of SKU's required
- Manufactured in our OE plant to Original Equipment specifications
- Available in lengths from 350mm to 800mm

1 Asymmetrical Spoiler
Resists windlift for improved performance even at high speed

2 Direct Fit Connector
Fits directly to the wiper arm without adding or removing loose parts

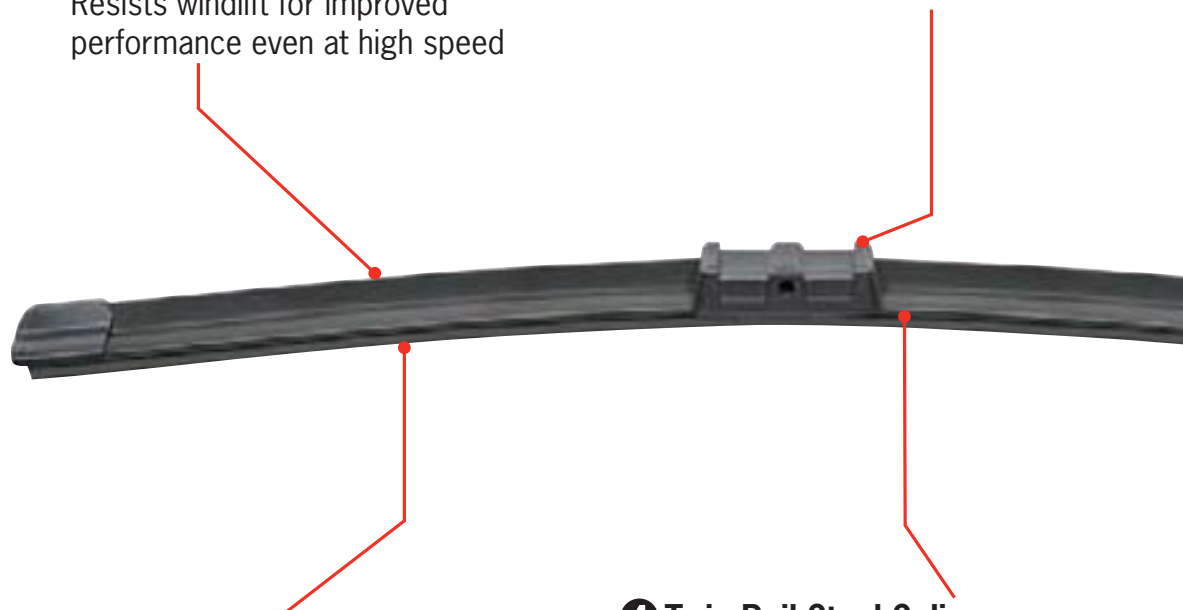

3 Trico Formulated Rubber
Unique dual material OE formulation with graphite coating for extended service life

4 Twin Rail Steel Spline
Twin rail rolled steel design gives even pressure distribution & reduces noise

DE Original Fit Beam-Hybridblätter

- Stilvolle Hybrid-Wischerblätter, die sich für die meisten modernen japanischen und koreanischen Fahrzeuge eignen
- In der Substruktur der Wischerausführung kommt moderne Wischertechnologie für eine optimale Druckverteilung zum Einsatz
- Stilvolle Plastik-Spoiler schützen das Wischerblatt und verbessern die Wischleistung
- Hergestellt in unserem OE-Werk nach Spezifikationen der Erstausrüster
- Kann auch zur Aufrüstung von Standardwischerblättern verwendet werden

1. Stilvoller Plastikspoiler - Bietet zuverlässigen Schutz für das Wischerblatt und sorgt für eine bessere Windabweisung
2. Patentierter Trico-Universal-Verbinder - Passt an alle gängigen Haken-Wischerarme mit den Abmessungen 9 x 3 mm und 9 x 4 mm
3. Beam-Wischerblatt-Substruktur - Stufenlose Druckpunkte sorgen für eine gleichmäßige Druckverteilung über die gesamte Länge des Wischerblatts
4. Exklusiver Trico-Verbinder - Zwei-Punkte-Ausführung sorgt für eine gleichmäßige Druckverteilung

FR Balais hybrides - montage d'origine

- Balais hybrides stylisés, tels que ceux montés sur la plupart des véhicules japonais et coréens actuels
- La sous-structure à profil aérodynamique utilise une technologie moderne de balayage du pare-brise, assurant une répartition optimisée de la pression
- Le déflecteur stylisé en plastique protège le balai et améliore la performance
- Fabriqués dans notre usine de production des pièces d'origine conformément aux spécifications des pièces d'origine
- Peut être également utilisés pour améliorer la performance et le style des balais d'essuie-glace traditionnels

1. Déflecteur stylisé en plastique - La coque haute résistance protège le balai et permet de réduire son soulèvement sous l'action du vent
2. Connecteur universel Trico - breveté Convient à tous les bras d'essuie-glace à crochets 9 x 3 mm et 9 x 4 mm
3. Sous-structure de balai profil aérodynamique - Les innombrables points de pression assurent une répartition homogène de la pression sur toute la longueur du balai
4. Coupleur exclusif à Trico - La conception à double point offre une répartition homogène de la pression

ES Escobillas híbridas de instalación original

- Escobilla híbrida estilizada adaptable a la mayoría de los vehículos japoneses y coreanos modernos
- Subestructura de tipo flexible que utiliza tecnología de limpieza moderna para optimizar la distribución de presión
- Alerón plástico estilizado que protege la escobilla y mejora el rendimiento
- Fabricadas en nuestra planta de EO según las especificaciones de equipos originales
- También se pueden utilizar como una alternativa superior a las escobillas limpiaparabrisas convencionales

1. Alerón plástico estilizado - El armazón de alta resistencia protege la escobilla y reduce la elevación por el efecto del viento
2. Conector universal patentado de Trico - Se adapta a todos los brazos limpiaparabrisas con gancho de 9 x 3 mm y 9 x 4 mm
3. Subestructura de las escobillas flexibles - Los puntos de presión infinitos proporcionan una distribución uniforme de la presión en toda la longitud de la escobilla
4. Acoplamiento exclusivo de Trico - El diseño de dos puntos ofrece una distribución uniforme de la presión

IT Spazzole ibride originali

- Spazzole ibride stilizzate come quelle installate nella maggior parte dei veicoli giapponesi e coreani moderni.
- La sottostruttura a spazzola piatta utilizza la moderna tecnologia di pulizia per ottimizzare la distribuzione della pressione.
- Lo spoiler in plastica stilizzato protegge la spazzola e migliora le prestazioni.
- Prodotto nel nostro stabilimento OE secondo le specifiche dei componenti originali.
- Utilizzabili anche come alternativa avanzata alle tradizionali spazzole per tergicristalli.

1. Spoiler in plastica stilizzato - Il guscio ad alta resistenza protegge la spazzola e riduce il carico del vento
2. Connettore universale Trico - brevettato Adatto a tutti i bracci a gancho da 9x3 mm e 9x4 mm
3. Sottostruttura del tergicristalli a spazzola piatta - I punti di pressione infiniti garantiscono una distribuzione uniforme della pressione per l'intera lunghezza della spazzola
4. Attacco Trico esclusivo - Il design a due punti offre una distribuzione uniforme della pressione

PT Escovas limpa-vidros híbridas de encaixe originais

- Escova híbrida estilizada como as equipadas na maioria dos veículos japoneses e coreanos modernos
- A subestrutura de estilo plano utiliza uma tecnologia de limpeza moderna para uma distribuição otimizada da pressão
- O spoiler estilizado de plástico protege a escova e melhora o desempenho
- Fabricadas na nossa fábrica de equipamento original de acordo com as especificações de equipamento original
- Também podem ser utilizadas como uma alternativa otimizada às escovas limpa-vidros convencionais

1. Spoiler de plástico estilizado - A estrutura de alta resistência protege a escova e reduz a elevação pelo vento
2. Conector universal patentado Trico - Encaixa em todos os braços de escovas limpa-vidros com gancho de 9 x 3 mm e 9 x 4 mm
3. Subestrutura das escovas limpa-vidros planas - Os pontos de pressão infinitos proporcionam uma distribuição uniforme da pressão em toda a extensão das escovas
4. Acoplador exclusivo Trico - O design de ponto duplo oferece uma distribuição uniforme da pressão

NL Originale hybride wisserbladen

- Stijlvol hybride blad dat op de meeste moderne Japanse en Koreaanse voertuigen te vinden is
- De substructuur in draagbladstijl gebruikt moderne wistechologie voor geoptimaliseerde verdeling van de druk
- De moderne plastic spoiler beschermt het blad en verbetert de prestaties
- Geproduceerd in onze OE-fabriek in overeenstemming met de specificaties van de oorspronkelijke apparatuur (Originale Equipment, OE)
- Kan ook worden gebruikt als upgrade van conventionele ruitenwisser

1. Gestyleerde plastic spoiler - Krachtige schaal beschermt blad en vermindert optillen door de wind
2. Geperateerde Trico universele connector - Past op alle wisserarmen met een haak van 9x3 mm & 9x4 mm
3. Substructuur van draagbladwisser - Oneindige drukpunten geven gelijkmatige drukverdeling over de volledige lengte van het blad
4. Exclusieve Trico-koppeling - Ontwerper met twinpunten biedt gelijkmatige drukverdeling

NO Hybridblader av original type

- Stilsterre hybridblader, som monter på de mest moderne japanske og koreanske kjøretøyene
- Understrukturen i bomstil bruker moderne visketeknologi for optimalisert trykkfordeling
- Stilstilt plastiflag plast sikrer bladet og forbedrer ytelsen
- Produseres ved OE-anlegget vår etter spesifikasjonene for originalt utstyr
- Kan også brukes som et oppgraderingsalternativ for vanlige vindusviskerblader

1. Stilstert plastspoiler - Ekstra sterk lag beskytter visker-blad og minsker vindbelastningen
2. Patentert universell - tilkobling fra Trico Passer til alle 9x3 og 9x4 mm viskerarmer med krokfester
3. Blad med flat understruktur - Uendelig mange trykkpunkter gir jevn trykkfordeling på tvers av hele bladlengden
4. Eksklusiv Trico-kobling - To-punks design gir jevn trykkfordeling

DK Originalmonterede hybridblade

- Stilserede hybridblade som de, der er monteret på de fleste moderne japanske og koreanske biler
- Flat-designs understruktur anvender moderne visketeknologi for optimal trykfordeling
- Stilstert plastspoiler beskytter bladet og fremmer ydeevnen
- Fremstillet på vores originaludstyrsfabrik i henhold til originaludstyrspecifikationer
- Kan også bruges som opgraderingsalternativ til konventionelle viskerblade

1. Smart plastspoiler - Stærk yderklædning beskytter bladet og giver mindre vindløft
2. Patentert universelt - Trico-beslag Passer til alle 9x3 mm og 9x4 mm viskerarmer med krog
3. Underdel med fladblad - Et uendeligt antal trykpunkter fordeler trykket jævnt langs hele bladet
4. Eksklusiv Trico-muffe - Topunktsdesignet fordeler trykket jævnt

SE Hybridblad med originalpassform

- Hybridtorkarblad i stilren design som passar de flesta moderna japanska och koreanska fordon
- Den bygelösa konstruktionen använder modern torkarteknik för optimal tryckfördelning
- Plastspoiler i stilren design skyddar torkarbladet och förbättrar prestandan
- Tillverkas i vår originaldelsfabrik enligt specifikationer för originalutrustning
- Kan också användas som ett uppgraderingsalternativ till konventionella torkarblad

1. Stiliserad plastspoiler - Robust hölje skyddar bladet och minskar vindlyft
2. Patentert Trico-universalslutare - Passar alla torkarblad med krok på 9x3 mm och 9x4 mm
3. Bygelös understruktur - Stor mängd tryckpunkter ger jämn tryckfördelning över hela bladet
4. Eksklusiv Trico-koppling - Utformning med dubbla punkter ger jämn tryckfördelning

PL Wycieraczki hybrydowe z oryginalnym mocowaniem

- Stylizowane pióro hybrydowe, takie jak montowane w większości japońskich i koreańskich pojazdów
- Wycieraczka płaska wykorzystująca nowoczesne technologie wycierania w celu optymalnego rozłożenia nacisku na szybę
- Stylowy plastikowy spoiler chroni pióro wycieraczki i poprawia jej działanie
- Wyprodukowano w naszej fabryce oryginalnego sprzętu zgodnie ze specyfikacjami oryginalnego sprzętu
- Mogą również służyć jako wyższej klasy zamienniki klasycznych piór wycieraczek

1. Spoiler plastikowy - Mocna osłona chroni pióro i redukuje efekt unoszenia się wycieraczki
2. Uniwersalna patentowana złączka Trico - Pasuje do wszystkich wycieraczek z uchwytem hakowym 9mm x 3mm i 9mm x 4mm
3. Konstrukcja wewnętrzna pióra płaskiego - Dzięki nieskończonej ilości punktów nacisku uzyskano równomierny rozkład nacisku na szybie na całej długości pióra
4. Unikutowa złączka Trico - Dwa punkty mocowania gwarantują równomierne rozłożenie nacisku na szybie

RU Гибридные щетки Original Fit

- Традиционная гибридная щетка, устанавливаемая на большинство современных японских и корейских автомобилей
- В конструкции бескаркасной щетки применяется современная технология очистки стекол для оптимального распределения давления
- Традиционный пластиковый спойлер защищает щетку и повышает эффективность ее работы
- Изготавливаются на собственном заводе по спецификациям оригинального оборудования
- Также можно использовать для усовершенствования обычных щеток стеклоочистителей

1. Традиционный пластиковый спойлер - Высокопрочный корпус защищает щетку и снижает воздействие подъемной силы ветра
2. Запатентованное универсальное - соединение Trico Подходит для всех стеклоочистителей с креплением типа «крючок» размером 9x3 мм и 9x4 мм
3. Конструкция бескаркасной щетки - Множество центров давления обеспечивают его равномерное распределение по всей длине щетки
4. Эксклюзивная соединительная муфта Trico - Двухточечная конструкция обеспечивает равномерное распределение давления

GR Υβριδικά μάκτρα τυπικού εξοπλισμού

- Στυλιζαρισμένο υβριδικό μάκτρο, όπως αυτό που τοποθετείται στα περισσότερα σύγχρονα ιαπωνικά και κορεάτικα οχήματα
- Η υποδομή μονοκόμματου στυλ χρησιμοποιεί εξελιγμένη τεχνολογία καθαρισμού για βελτιωμένη κατανομή της πίεσης
- Το στυλιζαρισμένο πλαστικό σπόιλερ προστατεύει το μάκτρο και βελτιώνει την απόδοσή
- Κατασκευάζονται στις εγκαταστάσεις κατασκευής προϊόντων για κατασκευαστές πρωτότυπου εξοπλισμού, σύμφωνα με τις προδιαγραφές των κατασκευαστών
- Μπορεί να χρησιμοποιηθεί επίσης ως εναλλακτική αναβάθμισης για τους συμβατικούς υαλοκαθαριστήρες

1. Στυλιζαρισμένο πλαστικό σπόιλερ - Κέλφος υψηλής αντοχής που προστατεύει το μάκτρο και μειώνει την ανύψωσή από τον αέρα
2. Κατοχυρωμένος σύνδεσμος Trico - γενικής χρήσης Τοποθετείται σε όλους τους αριστουργούς βραχιόνες υαλοκαθαριστήρων 9x3 mm και 9x4 mm
3. Υποδομή μονοκόμματου υαλοκαθαριστήρα - Άπτερα σημεία πίεσης αποδίδουν ομοιόμορφη κατανομή πίεσης σε όλο το μήκος του μάκτρος
4. Αποκλειστικός εύκτης Trico - Η σχεδίαση δύο σημείων προσφέρει ομοιόμορφη κατανομή της πίεσης

IS Hybrid-purrkublöð fyrir fyrirleggjandi festingar

- Sérhönnuð hybrid-purrkublöð sem passa á flesta nýlega japanska og kóreska bíla
- Undirbygging purrkublaða í þessum stíl byggir á nútímalegri tækni sem miðar að hámarksdreifingu þrýstings
- Sérhönnuð plastbláka hlífir purrkublaðinu og bætir afköstin
- Framleidd í verksmíðju okkar samkvæmt tæknisýningu fyrir upprunalegan búnað
- Má einnig nota sem uppfærslu á hefðbundnum purrkublöðum

1. Sérhönnuð vindskéið úr plasti - Hlífur úr sérstyrktu plasti verja blöðin og minnka vindmótstöðu
2. Einkaleyfandi fjónota - Trico-tengi Passar á alla 9x3 mm og 9x4 mm purrkuarma með krókum
3. Undirbygging purrkublaðsins - Þrepalausir þrýstingspunktar jafna dreifingu þrýstings yfir purrkublaðið endilangt
4. Sérhönnuð Trico-tengi - Tvöfaldir þrýstingspunktar jafna dreifingu þrýstings

CZ Originální hybridní lišty stěračů

- Stylizované hybridní lišty, jež jsou osazovány na většinu moderních japonských a korejských automobilů
- Substruktura lišty využívá moderní technologii stírání zaručující optimální rozložení tlaku
- Stylizovaný plastový spoiler chrání lištu a vylepšuje výkon
- Vyráběno v našem závodě podle specifikací vyhovujících originálnímu vybavení
- Lze použít rovněž jako alternativní vylepšení lišt tradičních stěračů

1. Stylizovaný plastový spoiler - Velmi silné pouzdro chrání stěrač a snižuje vztlak větru
2. Patentovaný univerzální - Trico konektor Vhodný do všech 9x3mm a 9x4mm závěsných ramen stěračů
3. Pružný nosník stěračů - Nekonečný počet bodů dotyku umožňuje rovnoměrné rozložení tlaku po celé délce stěračů
4. Exkluzivní spřáhlo Trico - Dvoubodová konstrukce umožňuje rovnoměrné rozložení tlaku

FI Original Fit-hybridipyyhkiänsulat

- Tyyllitellyt hybridipyyhkiänsulat sopivat useimpiin nykyaikaisiin japanilaisiin ja koreilaisiin ajoneuvoihin
- Pyyhkiänsulkutyölin alusrakenne käyttää nykyaikaisia pyyhkiänsulkutekniikkaa paineen jakautumisen optimoimiseksi
- Tyyllitellyt muovinen spoileri suojaaa pyyhkiänsulkua ja parantaa sen suorituskykyä
- Valmistettu alkuperäistehtäsamme alkuperäisen valmistajan tietojen mukaisesti
- Voidaan käyttää myös uutena vaihtoehtona perinteisten pyyhkiänsulkujen tilalla

1. Tyyllitellyt muovinen ilmanohjain - Kestävä kuori suojaaa pyyhkiänsulkua ja vähentää tuulen aiheuttamaa nostetta
2. Patentoitu Trico-yleisliitin - Sopii kaikkiiin 9x3 mm:n ja 9x4 mm:n koukulla varustettuihin pyyhkiäjän variisiin
3. Rungottoman pyyhkiänsulan alusrakenne - Ääretön määrä painepisteitä takaa paineen tasaisen jakautumisen koko pyyhkiänsulan pituudella
4. Erityinen Trico-liitin - Kahden pisteen muotoilu takaa tasaisen paineen jakautumisen

EE Original Fit hübridiharjad

- Stiiseeritud hübridiharjad sobivad enamikule tänapäevastele Jaapani ja Korea sõidukitele.
- Raamikonstruktsiooni alusstruktuur kasutab surve optimeeritud jaotamiseks tänapäevast klaasipuhastustehnoloogiat
- Stiiseeritud plastspoiler kaitseb harja ja parandab töövõimet
- Valmistatud meie OE tehases originaalse teavuosade spetsifikatsioonide alusel
- Saab kasutada ka tavalistele klaasipuhasti harjade uuendamise alternatiivina

1. Stiiseeritud plastspoiler - Suure tugevusega korpus kaitseb harja ja vähendab tuuletõstet
2. Trico patenteeritud universaalne liitmik - Sobib kõikide 9x3 mm ja 9x4mm haakklaispuhasti hoobadega
3. Raamiga klaasipuhasti alusstruktuur - Astmeteta survepunktide tagavah ühtlase survejotuse üle kogu harja pikluse
4. Eksklusivne Trico ühendus - Kahepunktiline konstruktsioon tagab ühtlase survejotuse

RO Lame hibrid cu montare originală

- Lamă hibrid stilizată montată pe majoritatea vehiculelor moderne din Japonia și Coreea
- Substructura fără cadru aplică tehnologia modernă de ștergere pentru distribuția optimizată a presiunii
- Spoilerul stilizat din plastic protejează lama și îmbunătățește performanța
- Fabricate în fabrica noastră de echipamente originale conform specificațiilor privind echipamentele originale
- Se poate utiliza și ca alternativă modernă la lamele de ștergător convenționale

1. Spoiler stilizat, din plastic - Carcasa foarte rezistentă protejează lama și reduce portanța
2. Conector universal brevetat Trico - Se fixează pe toate brațele de ștergător cu cârlig de 9x3 mm și 9x4 mm
3. Sub-structura lamei fără cadru - Punctele infinite de presiune oferă distribuția uniformă a presiunii pe toată lungimea lamei
4. Sistem de cuplare exclusiv Trico - Designul dublu oferă distribuția uniformă a presiunii

SI Zdržljive hibridne metlice

- Stilska hibridna metlica, ki je nameščena na večini sodobnih japonskih in korejskih vozilih
- Ploska podstruktura uporablja sodobno tehnologijo za brisanje za enakomerno porazdelitev pritiska
- Stilski plastični nastavek ščiti metlico in izboljša delovanje
- Proizvedene v našem obratu OE po specifikacijah originalne opreme
- Prav tako jih lahko uporabite za alternativno nadgradnjo konvencionalnih brisalcev

1. Stiliziran plastičen spoiler - Močno ogrodje ščiti metlico in zmanjšuje vetrni upor
2. Patentiran univerzalni priključek Trico - Prilega se vsem nosilem brisalcev s kavlji velikosti 9x3mm in 9x4mm
3. Osnovna metlice z nosilcem - Neskončno število točk pritiska na brisalcu omogoča enakomerno porazdelitev pritiska po celotni dolžini metlice
4. Ekskluzivna spojka Trico - Dvotočkovna zasnova zagotavlja enakomerno porazdelitev pritiska

TRICO Exact Fit®



Original Quality Fit, Form & Function. 

Original Fit Hybrid Blades

- Stylised hybrid blade as fitted to most modern Japanese & Korean vehicles
- Beam style sub structure uses modern wiping technology for optimised pressure distribution
- Stylised plastic spoiler safeguards the blade & improves performance
- Manufactured in our OE plant to Original Equipment specifications
- Can also be used as an upgrade alternative to conventional wiper blades
- Available in lengths from 350mm to 700mm

1 Stylised Plastic Spoiler
High strength shell safeguards blade & reduces windlift

2 Patented Trico Universal Connector
Fits all 9x3mm & 9x4mm hook wiper arms

3 Beam Blade Sub Structure
Infinite pressure points give even pressure distribution across the whole blade length

4 Exclusive Trico Coupler
Twin point design offers even pressure distribution

Trico Hybrid wiper blades can also be used as a **retro-fit upgrade** to **upgrade conventional hook arm** wiper blades to the **latest hybrid technology.**



DE Original Fit Standardwischerblätter

- Umfassendes Angebot an Standardwischerblättern zur Direktmontage
- Lieferumfang umfasst Standardhakenwischerarme, unsere einzigartigen Verbinder sowie Wischerblätter mit Sprayclip.
- Aus extrem stabilem Stahl für eine maximale Wischleistung bei allen Wetterbedingungen
- Hergestellt in unserem OE-Werk nach Spezifikationen der Erstausrüster

1. Originalteil-Struktur - Vollmetallkonstruktion für eine höhere Widerstandsfähigkeit
2. Direct-Fit-Verbinder - Lässt sich direkt auf den Wischarm aufstecken, ohne dass man lose Teile entfernen oder hinzufügen muss
3. Gummi nach Trico-Rezeptur - Einzigartige Originalteil-Rezeptur von Trico mit Graphitbeschichtung für eine bessere Wischleistung und eine längere Produktlebensdauer
4. Aerodynamisches Design - Entlüftete Struktur für eine höhere Windabweisung, auch bei hohen Geschwindigkeiten

FR Balais traditionnels - montage d'origine

- Gamme complète de balais d'essuie-glace traditionnels à montage direct
- Comprend les balais pour bras d'essuie-glace traditionnels à crochet, les connexions uniques spécialisées, et les balais avec gicleur et clip de maintien.
- Conception en acier haute résistance pour une performance maximale dans toutes les conditions météorologiques
- Fabriqués dans notre usine de fabrication des pièces d'origine conformément aux spécifications des pièces d'origine

1. Structure d'origine - Toute la construction est métallique pour une résistance accrue
2. Connecteur direct - Se monte directement au bras de l'essuie-glace sans ajout ou retrait de pièces indépendantes
3. Caoutchouc de formulation Trico - Formulation unique d'origine Trico avec revêtement graphite pour une meilleure performance et une durée de vie prolongée
4. Conception aérodynamique - La structure ventilée permet de réduire le soulèvement du balai sous l'action du vent à grande vitesse

ES Escobillas convencionales de instalación original

- Amplia gama de escobillas limpiaparabrisas convencionales de instalación directa
- Incluye escobillas para brazo limpiaparabrisas con gancho tradicional, conexiones únicas especiales y escobillas humedecidas con vaporizador.
- Diseño de acero de gran resistencia para lograr el mejor rendimiento en todas las condiciones climáticas
- Fabricadas en nuestra planta de EO según las especificaciones de equipos originales

1. Estructura de estilo de los EO - Todas las estructuras son de metal para proporcionar una resistencia mejor.
2. Conector de instalación directa - Se instala directamente en el brazo limpiaparabrisas sin necesidad de añadir ni quitar piezas sueltas.
3. Goma formulada de Trico - Formulación de los EO exclusiva de Trico con revestimiento de grafito para proporcionar un rendimiento mejor y prolongar la vida útil.
4. Diseño aerodinámico - La estructura ventilada reduce la elevación por el efecto del viento a alta velocidad.

IT Spazzole tradizionali originali

- Gamma completa di spazzole per tergicristalli tradizionali a montaggio diretto.
- Comprende spazzole tradizionali per bracci a ganccio, speciali raccordi unici e spazzole umide con fermo per l'ugello.
- La struttura in acciaio ad alta resistenza assicura prestazioni ottimali in qualsiasi condizione meteorologica.
- Prodotte nel nostro stabilimento OE secondo le specifiche dei componenti originali.

1. Struttura stile OE - Struttura interamente in metallo per una maggiore resistenza
2. Connettore per montaggio diretto - Si innesta direttamente sul braccio del tergicristallo senza aggiungere o rimuovere parti staccabili
3. Gomma dalla formulazione Trico esclusiva - Formulazione OE Trico esclusiva con rivestimento in grafite per prestazioni migliori e durata più elevata
4. Design aerodinamico - La struttura ventilata riduce il carico del vento a velocità elevate

PT Escovas convencionais de encaixe originais

- Gama completa de escovas limpa-vidros convencionais de encaixe direto
- Inclui escovas limpa-vidros com braço em gancho tradicionais, ligações especializadas exclusivas e escovas molhadas com dipe de spray.
- Design em aço altamente resistente para o máximo desempenho em todas as condições climáticas
- Fabricadas na nossa fábrica de equipamento original de acordo com as especificações de equipamento original

1. Estrutura estilizada original - Estrutura totalmente de metal para oferecer uma maior resistência
2. Conector de encaixe direto - Encaixa diretamente no braço das escovas limpa-vidros sem necessidade de inserir ou remover peças soltas
3. Borracha formulada Trico - Formulação exclusiva original Trico com revestimento de grafite para oferecer um desempenho superior e uma vida útil prolongada
4. Design aerodinâmico - A estrutura ventilada reduz a elevação pelo vento a alta velocidade

NL Originele conventionele wisserbladen

- Volledig bereik van rechtstreeks aan te brengen conventionele wisserbladen
- Inclusief wisserarmbladen met traditionele haak, gespecialiseerde unieke aansluitingen en natte bladen met spuitclip.
- Extra krachtig stalen ontwerp voor maximale prestaties onder alle weersomstandigheden
- Geproduceerd in onze OE-fabriek in overeenstemming met de specificaties van de oorspronkelijke apparatuur (Originele Equipment, OE)

1. Structuur in OE-stijl - Volledig metalen constructie voor verbeterde kracht
2. Direct aan te brengen connector - Past rechtstreeks op de ruitwisserarm zonder toevoeging of verwijdering van losse onderdelen
3. Trico geformuleerd rubber - Unieke Trico OE-formulering met grafietcoating voor verbeterde prestaties in een langere levensduur
4. Aerodynamisch ontwerp - Geventileerde structuur reduceert optillen door wind op hoge snelheid

NO Originale blader av vanlig type

- Komplet utvalg av vanlige vindusviskerblader med direkte montering
- Inkluderer tradisjonelle vindusviskerblader med heftefunksjon, unike spesialkoblinger og våte blader med sprayklemme.
- Kraftig stål design for maksimal ytelse under alle værforhold
- Produseres ved OE-anlegget vår etter spesifikasjonene for originalt utstyr

1. Struktur i OE-stil - Helmetallkonstruksjon for bedre styrke
2. Kobling for direkte montering - Passer direkte på viskerammen nye deler eller fjerning av løse deler
3. Gummi av Trico-formel - Unik Trico OE-sammensetning med grafittbelegg som gir bedre ytelse og lengre levetid
4. Aerodynamisk utforming - Ventilert struktur reduserer vindbelastningen ved høye hastigheter

DK Originalmonterede konventionelle blade

- Komplet udvalg af direkte monterede konventionelle viskerblade
- Omfatter traditionelle viskerarmblade med krog, særlige, unikke forbindelser og våde blade med sprayklips.
- Højstyrke stål design for maksimal ydeevne i alle vejrforhold
- Fremstillet på vores originaludstyrsfabrik i henhold til originaludstyrspecifikationer

1. OE-stilstruktur - 100 % metalkonstruktion giver bedre styrke
2. Beslag til direkte montering - Passer direkte på viskerarmen uden at tilføje eller fjerne løse dele
3. Trico-udformet gummi - Unik Trico OE-udformning med grafittbelægning, som forbedrer ydeevnen og forlænger holdbarheden
4. Aerodynamisk design - Den ventilerede struktur giver mindre vindloft ved høj hastighed

SE Konventionella torkarblad med originalpassform

- Komplet utbud av direktpassande konventionella torkarblad
- Inkluderar traditionella torkarblad för torkarmar med krok, specialfästen och wet blades med sprayclip.
- Design i hållfast stål för maximal prestanda i alla väderförhållanden
- Tillverkas i vår originaldelningsfabrik enligt specifikationer för originalutrustning

1. Originaldelstruktur - Konstruktion helt i metall för förbättrad styrka
2. Direktpassande anslutare - Monteras direkt på torkarbladen utan montering eller borttagning av lösa delar
3. Trico-utformat gummi - Unik Trico-originaldelutformning med grafittbelägning för förbättrad prestanda och längre tjänstlevnad
4. Aerodynamisk design - Lufthålsstruktur minskar vindlyft vid höga hastigheter

PL Wycieraczki klasyczne z oryginalnym mocowaniem

- Kompletna oferta klasycznych piór wycieraczek z mocowaniem bezpośrednim
- Asortyment obejmuje pióra wycieraczek klasycznych z uchwytem hakowym, specjalne złączki oraz pióra wycieraczek ze spryskiwaczem
- Trwała konstrukcja stalowa gwarantuje najwyższą wydajność w każdych warunkach atmosferycznych
- Wyprodukowano w naszej fabryce oryginalnego sprzętu zgodnie ze specyfikacjami oryginalnego sprzętu

1. Konstrukcja w stylu oryginalnego sprzętu - Konstrukcja wykonana w całości z metalu dodatkowo wzmacnia wycieraczkę
2. Złączka bezpośrednia - Umożliwia mocowanie bezpośrednie do ramion wycieraczek bez konieczności dodawania lub usuwania luźnych elementów
3. Formowanie gumy w technologii Trico - Originalna technologia formowania gumy Trico z dodatkową powłoką grafitową przedłuża żywotność wycieraczek i poprawia ich działanie
4. Aerodynamiczny kształt - Otwory w konstrukcji redukują efekt unoszenia się wycieraczki przy dużych prędkościach

RU Классические щетки Original Fit

- Полный ассортимент классических щеток стеклоочистителей с предусмотренными адаптерам
- Включает щетки стеклоочистителей с классическим креплением типа "крючок", специальные уникальные соединения и щетки Wet Blade с креплением спрей-клип (spray clip).
- Конструкция из высокопрочной стали для непревзойденной эффективности работы в любых погодных условиях
- Изготавливаются на собственном заводе по спецификациям оригинального оборудования

1. Оригинальная конструкция от производителя - Цельнометаллическая конструкция обеспечивает повышенную прочность
2. Соединение с предусмотренным адаптером - Устанавливается непосредственно на рычаг стеклоочистителя, нет необходимости устанавливать или снимать отдельные детали
3. Состав каучука от компании Trico - Уникальный состав материала от производителя Trico с графитовым покрытием для повышенной эффективности и длительного срока службы
4. Аэродинамическая конструкция - Вентилируемая структура уменьшает подъемную силу ветра на высоких скоростях

GR Συμβατικά μάρκτρα τυπικού εξοπλισμού

- Πλήρης σειρά συμβατικών μάρκτρων υλοκαθαριστήρων άμεσης τοποθέτησης
- Περιλαμβάνει παραδοσιακά μάρκτρα υλοκαθαριστήρων με ακριβιστικό βροχίονα, ειδικούς μονοβόλιους συνδέσμους και μάρκτρα υγρού, με κλιτ φακισμού.
- Σχεδιάση υψηλής αντοχής από χάλυβα, για μείωση απόδοσης υπό όλες τις καιρικές συνθήκες
- Κατασκευάζονται στις εγκαταστάσεις κατασκευής προϊόντων για κατασκευαστές πρωτότυπου εξοπλισμού, σύμφωνα με τις προδιαγραφές των κατασκευαστών

1. Δομή τύπου πρωτότυπου εξοπλισμού - Κατασκευή εξ ολοκλήρου από μέταλλο για βελτιωμένη αντοχή
2. Συνδέσμος άμεσης τοποθέτησης - Τοποθετείται απευθείας στο βροχίονα του υλοκαθαριστήρα χωρίς προθήκη ή αφαίρεση χαλαρών εξαρτημάτων
3. Καουτσούκ μορφοποιημένο από την Trico - Μοναδική σύνθεση πρωτότυπου εξοπλισμού Trico με επίστρωση από γραφίτη για βελτιωμένη απόδοση και παρατεταμένη διάρκεια χρήσης
4. Αεροδυναμική σχεδίαση - Η αεριζόμενη δομή μειώνει την ανύψωση από τον αέρα στις υψηλές ταχύτητες

IS Hefþöfundin þurrkblöð fyrir fyrirliggjandi festingar

- Fullbúin lína af hefþöfundum þurrkblöðum til beinnar uppsetningar
- Þar á meðal eru þurrkblöð fyrir hefþöfundna krókaarma, sértengi og blautblöð með úðaklemmu.
- Hönnuð úr hertu stáli til að skila hámarksföstum við öll skilyrði
- Framleidd í verkmiðju okkar samkvæmt tæknilyngingu fyrir upprunalegan búnað

1. Upprunalegur still og smíði - Allir hlutar eru úr málm til að auka þolið
2. Milliútlást tengi - Fellur beint á þurrkauminn án þess að bæta þurfi við eða fjarlægja lausa hluta
3. Mótað gummi frá Trico - Einstök upprunaleg Trico-samsetning með grafithöðun til að bæta frammiððu og lengja notkunartíma
4. Straumlinuðugð hönnun - Uppbygging með göðu loflíflæði dregur úr vindmótstöðu við mikinn hraða

CZ Originální tradiční listy stěračů

- Kompletní portfolio přímo osaditelných tradičních listů stěračů
- Obsahuje klasické listy pro háková ramena stěračů, speciální jedinečné spojky a listy se svorkou ostřikovače.
- Odolné ocelové provedení zaručující maximální výkon za všech povětrnostních podmínek
- Vyráběno v našem závodě podle specifikací vyhovujících originálnímu vybavení

1. Kvalitní originální díly - Zvýšená odolnost díky celokovové konstrukci
2. Přesné pasující konektor - Pasuje přesně do ramena stěračů bez nutnosti přidat nebo odstranit nepřipravené části
3. Guma vytvořená společností Trico - Speciální složení pro originální díly Trico s grafitovým potahem zlepšujícím výkonnost a prodlužujícím životnost výrobku
4. Aerodynamický tvar - Systém odvětrávání snižuje vztlak větru při vysokých rychlostech

FI Perinteiset Original Fit -pyyhkijänsulat

- kattava valikoima suoraan asennettavia perinteisiä pyyhkijänsulkiä
- Sisältää perinteisiä koukkukinnityksiä pyyhkijänsulkiä, ainutlaatuisia erityislaitantöitä ja märkeä pyyhkijänsulkiä ruiskulaitännällä.
- Sitkeästä teräksestä valmistettu pyyhkijänsulan suorituskyyky on mahdollisimman hyvä kaikissa olosuhteissa
- Valmistettu alkupeitteistä osista alkupeitteen valmistajan tietojen mukaisesti

1. OE-tyylinen rakenne - Valmistettu kokonaan metallista kestävyuden parantamiseksi
2. Suoraan asennettava liitin - Asennetaan suoraan pyyhkijän varteen ilman irto-osien lisäämistä tai poistamista
3. Trico:n kehittelemä kumi - Ainutlaatuinen Trico OE-muotoilu grafitipinnoitteella lisää suorituskyykyä ja pidentää käyttöikää
4. Aerodynaaminen muotoilu - Ilmareiälli varustettu rakenne vähentää tuulen nostetta suurissa ajoneuvoissa

EE Original Fit tavapäraseid harjad

- Terviklik valik tavapärase otselihendusega klaasipuhasti harjaid
- Hõlmab traditsioonilisi haagiga klaasipuhasti harju, eritoetena unikaalseid liitmikke ja niiskeid harju koos pihustusklambriaga
- Suure tugevusega terasest konstruktsioon maksimaalseks jõudluks kõigis ilmatingimustes
- Valmistatud meie OE tehases originaalse teavuosade spetsifikatsioonide alusel

1. OE-stiili struktuur - Täismetallkonstruktsioon tugevuse parandamiseks
2. Direct Fit liitmik - Sobib klaasipuhasti hoovaga lahtise osade lisamise või eemaldamiseks
3. Trico spetsiaalne koostisega kummi - Unikaalne grafitkattega Trico OE koostis paremaks toimimiseks ja kasutusea pikendamiseks
4. Aerodünaamiline konstruktsioon - Ventileeritud struktuur vähendab tuuletõstet suurel kiirusel

RO Lame convenționale cu montare originală

- Gamă completă de lame de ștergător convenționale cu montare directă
- Include lame pentru brațe de ștergător tradiționale tip cărlig, elemente de conectare unice speciale și lame racordate la lichid cu duză de pulverizare.
- Realizat din oțel de înaltă rezistență pentru performanță maximă indiferent de condițiile meteorologice
- Fabricate în fabrica noastră de echipamente originale conform specificațiilor privind echipamentele originale

1. Structură de tip echipament original - Construcție completă din metal pentru o rezistență îmbunătățită
2. Conector cu montare directă - Se fixează direct pe brațul de ștergător fără a adăuga sau a îndepărta piesele destrăse
3. Cauciuc formulat Trico - Formulare unică Trico, de tip echipament original, cu strat de acoperire din grafit pentru performanță îmbunătățită și o durată de funcționare prelungită
4. Design aerodinamic - Structura ventilată reduce portanța la viteze mari

SI Zdržljive konvencionalne metlice

- Celovita paleta konvencionalnih metlic za brisanje za neposredno vgradnjo
- Vključuje tradicionalne ključaste ročice za brisanje, posebne edinstvene priključke in metlice z razpršilno sponko.
- Zasnovana visoko trdnega jekla za maksimalno učinkovitost v vseh vremenskih pogojih.
- Proizvedeno v našem obratu OE po specifikacijah originalne opreme

1. Struktura v stilu originalne opreme - Samo kovinska struktura za večjo moč
2. Priključek za neposredno namestitve - Namestitve neposredno na nosilec brisalca brez dodajanja ali odstranjevanja nepripravljenih delov
3. Sestavljena guma Trico - Edinstvena sestava kot originalna oprema Trico z grafitno prevleko za boljše učinkovitost in daljšo življenjsko dobo
4. Aerodinamična zasnova - Zračna struktura zmanjšuje vetrni upor pri visokih hitrostih

TRICO Exact Fit[®]



Original Quality Fit, Form & Function. 

Original Fit Conventional Blades

- Complete range of direct fit conventional wiper blades
- Includes traditional hook wiper arm blades, speciality unique connections, and wet blades with spray clip.
- High strength steel design for maximum performance in all weather conditions
- Manufactured in our OE plant to Original Equipment specifications
- Available in lengths from 280mm to 700mm

① OE Style Structure

All metal construction for improved strength

② Direct Fit Connector

Fits directly to the wiper arm without adding or removing loose parts

③ Trico Formulated Rubber

Unique Trico OE formulation with graphite coating for improved performance and extended service life

④ Aerodynamic Design

Vented structure reduces windlift at high speeds

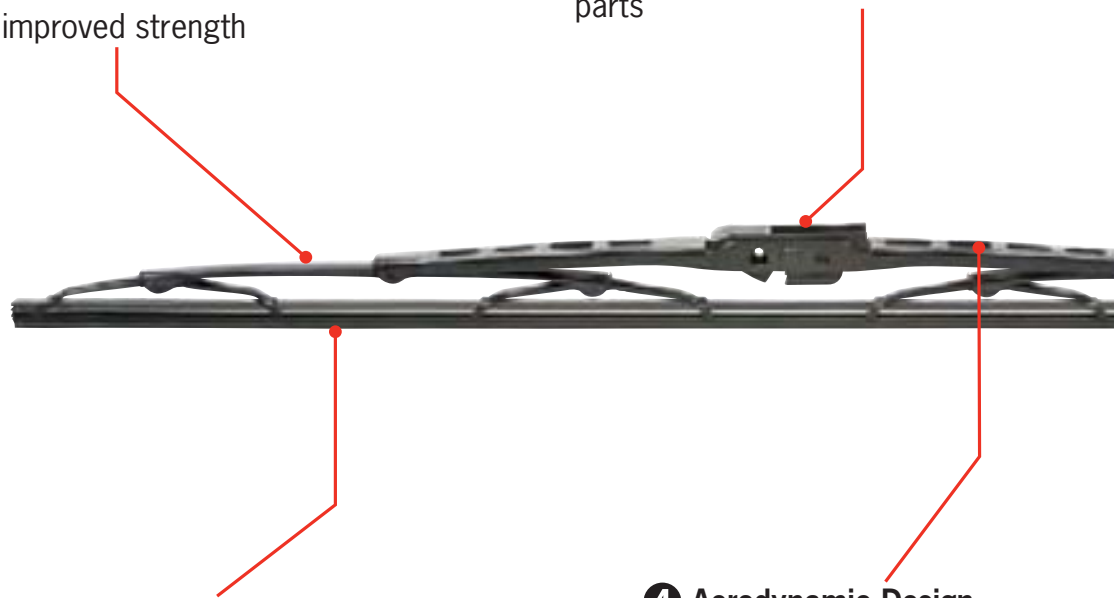

EF600
600mm 24"

TRICO Exact Fit[®]

DIRECT
FACTORY
REPLACEMENT

DE

Speciality Fit Heckscheibenwischerblätter

- Umfassendes Angebot an Designer-Heckscheibenwischerblättern mit besonderer Passgenauigkeit
- Einschließlich Standard-, Kunststoff-, Spritzguss- und Beam-Ausführung
- Gelbe Markierung auf der Verpackung für eine einfache Lagerung und Lokalisierung
- Hergestellt in unserem OE-Werk nach Spezifikationen der Erstausrüster

1. Beam-Ausführung - Struktur im Beam-Design für eine gleichmäßige Druckverteilung
2. Original-Fit-Verbinder - Für einen schnellen und einfachen Direkt-Austausch
3. Spritzgussausführung - Originalteil-Ausführung mit hoher UV-Beständigkeit
4. Gummi nach Trico-Rezeptur - Graphitbeschichtung für eine bessere Wischleistung und eine längere Produktlebens- dauer

FR

Balais spécialisés pour pare-brise arrière

- Gamme complète de balais d'essuie-glace spécialement conçus pour les pare-brises arrière
- Comprend les balais conventionnels, stylisés en plastique et les balais plats
- Repère jaune sur l'emballage pour faciliter le stockage et l'identification
- Fabriqués dans nos usines de production de pièces d'origine conformément aux spécifications des pièces d'origine

1. Style à profil aérodynamique - Structure à profil aérodynamique pour une répartition homogène de la pression
2. Connexions à montage d'origine - Pour un remplacement direct simple et rapide
3. Style plastique moulé - Qualité d'origine à haute résistance aux UV
4. Caoutchouc de formulation Trico - Revêtement graphite pour une meilleure performance et une durée de vie prolongée

ES

Escobillas de instalación especial para luna trasera

- Amplia gama de escobillas limpiaparabrisas de diseño especial para luna trasera
- Incluye los diseños convencional, de plástico moldeado y flexible
- El color amarillo distintivo del embalaje hace posible que se almacenen y se localicen fácilmente
- Fabricadas en nuestra planta de EO según las especificaciones de equipos originales

1. Estilo flexible - Estructura de estilo flexible para proporcionar una distribución uniforme de la presión.
2. Conexiones de instalación de los EO - Para una sustitución directa, rápida y sencilla.
3. Diseño de plástico moldeado - Diseño de los EO con gran resistencia a los rayos UV.
4. Goma formulada de Trico - Con revestimiento de grafito para proporcionar un rendimiento mejor y prolongar la vida útil.

IT

Spazzole per tergicristallo dal design particolare

- Gamma completa di spazzole per tergicristallo dal design particolare
- Comprende design tradizionali, in plastica stampata e a spazzola piatta.
- Il contrassegno giallo sulla confezione semplifica lo stoccaggio e l'identificazione.
- Prodotto nel nostro stabilimento OE secondo le specifiche dei componenti originali.

1. Spazzola piatta - Struttura a spazzola piatta per una distribuzione uniforme della pressione
2. Raccordi OE - Per una sostituzione diretta semplice e rapida
3. Plastica stampata - Design OE con alta resistenza ai raggi UV
4. Gomma dalla formulazione Trico esclusiva - Rivestimento in grafite per prestazioni migliori e durata più elevata

PT

Escovas do limpa-vidros traseiro de encaixe especializadas

- Gamma completa de escovas do limpa-vidros traseiro de marca especializadas
- Inclui os designs convencional, em plástico moldado e planas
- Destaque amarelo na embalagem para um fácil armazenamento e identificação
- Fabricadas na nossa fábrica de equipamento original de acordo com as especificações de equipamento original

1. Escovas limpa-vidros planas - Estrutura com design plano para uma distribuição uniforme da pressão
2. Ligações de encaixe originais - Para uma substituição direta rápida e fácil
3. Design em plástico moldado - Design original com alta resistência a raios UV
4. Borracha formulada Trico - Com revestimento de grafite para oferecer um desempenho superior e uma vida útil prolongada

NL

Achternruitwissers met gespecialiseerde aansluiting

- Volledig assortiment achternruitwissersbladen met gespecialiseerd ontwerp
- Inclusief conventioneel, voorgevormd plastic en draagbladontwerp
- Duidelijk gele verpakking voor gemakkelijk voorraadbeheer en identificatie
- Geproduceerd in onze OE-fabriek in overeenstemming met de specificaties van de oorspronkelijke apparatuur (Originele Equipment, OE)

1. Draagarmstijl - Draagarmontwerp voor gelijkmatige drukverdeling
2. OE-passende verbindingsstukken - Voor snelle en gemakkelijke directe vervanging
3. Gegoten plastic stijl - OE-styling met hoge UV-weerstand
4. Trico geformuleerd rubber - Grafietcoating voor verbeterde prestaties en langere levens-duur

NO

Vindusviskerblader med spesialtilpassing for bakvindu

- Komplet utvalg av vindusviskerblader med spesialtilpassing for bakvindu
- Inkluderer designene konvensjonell, støpt plast og bom
- Gult kjennetegn på emballasjen for enkel lageroppbevaring og identifikasjon
- Produseres ved OE-anlegget vår etter spesifikasjonene for originalt utstyr

1. Flat stil - Flat struktur gir jevn trykkfordeling
2. OE-hurtigkoblinger - Gir rask enkel og direkte utskifting
3. Støpt plast-utforming - OE-styling med høy UV-beskyttelse
4. Gummi av Trico-formel - Grafittbelegg som gir bedre ytelse og lengre levetid

DK

Specialmonterede bagrudeblade

- Komplet udvalg af specialdesignede bagrudeviskerblade
- Gamte konventionelle, støbte plastdesigns og flat-designs
- Gult karakteristisk træk på emballagen for let lagerføring og identificering
- Fremstillet på vores originaludstyrsfabrik i henhold til originaludstyrspecifikationer

1. Fladblad-stil - Fladblad-designstruktur fordeler fordeltrykket jævnt
2. OE-monteringsbeslag - Til hurtig og nem øjeblikkelig udskiftning
3. Formstøbt plaststil - OE-stil med høj UV-beskyttelse
4. Trico-udformet gummi - Grafittbelægning, der giver bedre resultater og længere holdbarhed

SE

Bakruteblad med specialfästen

- Komplet utbud av specialdesignede bakruteorkorblad
- Inkluderer konventionella design, designer i gjuten plast och bygelösa designer
- Det gula fältet på förpackningen gör det lätt att lagra och identifiera orkarbladen
- Tillverkas i vår originaldesignfabrik enligt specifikationer för originalutrustning

1. Bygelös konstruktion - Bygelös struktur för jämn jämn tryckfördelning
2. Anslutningar med originaldespassning - För snabbt och enkelt direktutbyte
3. Utförning med gjuten plast - Originaldesutförning med hög UV-resistens
4. Trico-utformat gummi - Grafittbeläggning för förbättrad prestanda och längre tjänstlev

PL

Specjalne pióra wycieraczek szyby tylnej

- Kompletna oferta specjalnie zaprojektowanych piór wycieraczek szyby tylnej
- Asortyment obejmuje pióra wycieraczek klasycznych, listew plastikowych i plastikich
- Żółte oznaczenie na opakowaniu ułatwia składowanie i identyfikację produktów
- Wyprodukowano w naszej fabryce oryginalnego sprzętu zgodnie ze specyfikacjami oryginalnego sprzętu

1. Kształt pióra płaskiego - Płaski kształt pióra gwarantuje równomierne rozłożenie nacisku
2. Oryginalne złączki - Szybki i prosta bezpośrednia wymiana pióra
3. Plastik formowany wtryskowo - Oryginalny styl i wysoka odporność na promieniowanie UV
4. Formowanie gumy w technologii Trico - Grafitowa powłoka poprawia działanie i przedłuża żywotność wycieraczki

RU

Специализированные щетки для заднего стекла

- Полный ассортимент специализированных щеток для заднего стекла
- Включает классическую конструкцию, конструкцию из литого пластика и бескаркасную конструкцию
- Желтая маркировка на упаковке для простой идентификации и правильного складирования
- Изготавливаются на собственном заводе по спецификациям оригинального оборудования

1. Бескаркасное исполнение - Бескаркасная конструкция обеспечивает равномерное распределение давления
2. Оригинальные соединения - Для быстрой и простой непосредственной замены
3. Конструктивное исполнение из литого пластика - Оригинальный дизайн с высокой стойкостью к УФ-излучению
4. Состав каучука от компании Trico - Графитовое покрытие для повышенной эффективности и длительного срока службы

GR

Μάτρα πίσω παρμπρίζ ειδικής τοποθέτησης

- Πλήρης σειρά μάτρων πίσω παρμπρίζ ειδικής σχεδίασης
- Περιλαμβάνει παραδοσιακά σχέδια, σχέδια από χυτό πλαστικό και σχέδια μονοκόμματου στυλ
- Κίτρινη επισήμανση στη συσκευασία, για εύκολη αποθήκευση και αναγνώριση
- Κατασκευάζονται στις εγκαταστάσεις κατασκευής προϊόντων για κατασκευαστές πρωτότυπου εξοπλισμού, σύμφωνα με τις προδιαγραφές των κατασκευαστών

1. Μονοκόμματο στυλ - Δομή μονοκόμματου στυλ για ομοιομορφή κατανομή της πίεσης
2. Συνεπείς πρωτότυπου εξοπλισμού - Για γρήγορη και εύκολη άμεση αντικατάσταση
3. Σχεδίαση από χυτό πλαστικό - Σχεδίαση πρωτότυπου εξοπλισμού με υψηλή αντίσταση στην ακτινοβολία UV
4. Καουτσούκ μορφοποιημένο από την Trico - Επίστρωση από γραφίτη για βελτιωμένη απόδοση και παρατεταμένη διάρκεια χρήσης

IS

Sérgerðir þurrkublaða fyrir afturrúðu

- Fullbúin lína sérhannaðra þurrkublaða fyrir afturrúðu
- Þar á meðal eru hefðbundnar gerðir, gerðir úr mótuðu plasti og sveigð blöð
- Umbúðir eru merktar með gulu til að auðvelda auðkenningu og geymslu á lager
- Framleidd í verksmíðu okkar samkvæmt tæknilyngingu fyrir upprunalegan búnað

1. Bogalaga hönnun - Bogadregin uppbygging til að dreifa þrýstingi jafna dreifingu þrýstings
2. Upprunaleg hönnun tengja - Gerir þurrkublaðaskipti auðveld og fljótleg
3. Hönnun með mótuðu plasti - Upprunaleg hönnun með miklu viðnámi gegn útfjöluðum geislum
4. Mótað gúmmí frá Trico - Grafittúðun til að bæta frammiðstöðu og lengja notkunartíma

CZ

Speciální lišty pro zadní stěračče

- Kompletní portfolio speciálních lišt pro stěračče zadního okna
- Zahnuje tradiční, tvarované plastové i bezramíkové lišty
- Žlutá značka na balení pro snadné uskladnění a identifikaci
- Vyroběno v našem závodě podle specifikací vyhovujících originálnímu vybavení

1. Tvar nosniku - Konstruční tvar nosniku pro rovnoměrné rozložení tlaku
2. Spoje určené pro originální díly - Pro rychlou a snadnou okamžitou výměnu
3. Rungotón odliček - Tvarování pro originální díly s vysokou odolností proti UV záření
4. Guma vytvořená společností Trico - Grafitový potah pro zvýšení výkonosti a prodloužení životnosti výrobku

FI

Speciality Fit -pyyhkijänsulat takaikkunaan

- Kattava valikoima erikoismallisia takaikkunan pyyhkijänsulkuja
- Sisältää niin perinteisiä, muovista valettuja kuin rungottomia pyyhkijänsulkamalleja
- Pakkaukset merkitty keltaisella varastoinnin ja tunnistamisen helpottamiseksi
- Valmistettu alkupeiristehtaassamme alkupeirisen valmistajan tietojen mukaisesti

1. Rungoton tyylit - Rungoton muotoilu takaa tasaisen paineen jakautumisen
2. OE-liittännät - Nopeasti ja helposti suoraan asennettava varaosa
3. Valumuovinen tyylit - OE-muotoilu erittäin hyvällä UV-säteilyn kestävyydellä
4. Tricon kehittämä kumi - Grafittipinnoitettu suorituskyvyn lisäämiseksi ja käyttöajan pidentämiseksi

EE

Speciality Fit tagaakna klaasipuhasti harjad

- Tagaakna klaasipuhasti spetsiaalse konstruktsiooniga harjade teraviklik valik
- Hõlmab tavapäraseid, vormitud plastist ja raamiga konstruktsioone
- Kollane märgis pakendil lihtsaks ladustamiseks ja identifitseerimiseks
- Valmistatud meie OE tehases originaalsete varaosade spetsifikatsioonide alusel

1. Raami stiil - Raami konstruktsioon surve ühtlaseks jaotuseks
2. OE FIT liitmikud - Kiireks ja lihtsaks asendamiseks
3. Vormitud plast-stiil - Kõrge UV-kindlusega OE-stiil
4. Trico spetsiaalse koostisega kummi - Grafitkattega, paremaks toimimiseks ja kasutusea pikendamiseks

RO

Lame pentru lunetă cu montare specială

- Gamă completă de lame de ștergător pentru lunetă cu design special
- Include modele convenționale din plastic turnat și de tip fără cadru
- Marcaj galben pe ambalaj pentru depozitare și identificare facilă
- Fabricate în fabrica noastră de echipamente originale conform specificațiilor privind echipamentele originale

1. Structură fără cadru - Structură fără cadru pentru distribuția uniformă a presiunii
2. Conectori cu montare directă, de tip echipament original - Pentru înlocuirea directă, rapidă și ușoară
3. Structură din plastic turnat - Structură de tip echipament original cu rezistență ridicată la raze UV
4. Cauciuc formulat Trico - Strat de acoperire din grafit pentru performanță îmbunătățită și durată de funcționare prelungită

SI

Posebni brisalci za zadnje steklo

- Celovita paleta posebnih brisalcev za zadnje steklo
- Vključuje konvencionalne oblike, oblike iz stisnjene plastike in ploske oblike
- Rumena označba na embalaži za lažje skladiščenje in identifikacijo
- Proizvedeno v našem obratu OE po specifikacijah originalne opreme

1. Stil z nosilcem - Zasnova z nosilcem za enakomerno porazdelitev pritiska
2. Priključki za namestitev kot pri originalni opremi - Za hitro in enostavno neposredno menjavo
3. Stil z ulito plastiko - Stil originalne opreme z visoko odpornostjo na UV-žarke
4. Sestavljena guma Trico - Z grafitno prevleko za boljšo učinkovitost in daljšo življenjsko dobo

TRICO Exact Fit®



Original Quality Fit, Form & Function. 

Speciality Fit Rear Screen Blades

- Complete range of speciality designer rear screen wiper blades
- Includes conventional, moulded plastic and beam style designs
- Yellow feature on packaging for easy stocking and identification
- Manufactured in our OE plant to Original Equipment specifications
- Available in lengths from 180mm to 500mm

1 Beam Style

Beam design structure for even pressure distribution



2 OE Fit Connections

For quick & easy direct replacement

3 Moulded Plastic Style

OE styling with high UV resistance

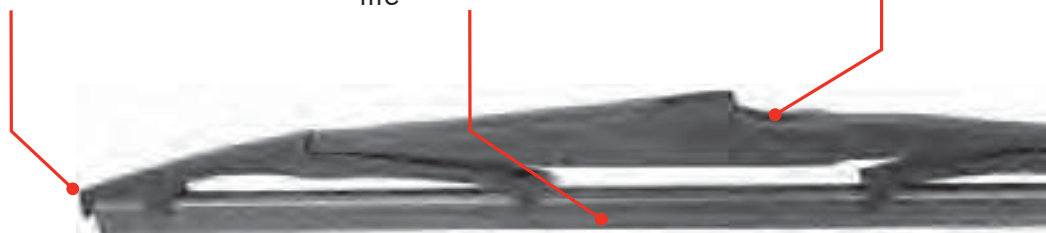

4 Trico Formulated Rubber

Graphite coated for improved performance & extended service life



- DE Multi-Fit Hochleistungsvischerblätter**
- Speziell für die aktuell gängigen stark gebogenen Windschutzscheiben entwickelt
 - VorTec™-Flügel sorgt für maximalen Kontakt mit der Windschutzscheibe bei Windstärken bis zu 220 km/h
 - Mit HighGlide ausstattetes Gummielment für einen leiseren Wischvorgang
 - Abdeckung von 96 % aller Fahrzeuge mit nur 20 Lagerposten

1. VorTec-Spoiler - Tiefsetzender, aerodynamischer Spoiler - Speziell entwickelt, um Luftturbulenzen standzuhalten und diese in Wischerdruck umzuwandeln
2. Einzigartiges Trico-Verbindungssystem - Passend für alle beliebten modernen Originalteil-spezifischen Wischerarme und Standardhakenwischerarme
3. Gummi nach Trico-Rezeptur - Gummi mit HighGlide behandelt, für einen geschmeidigeren, leiseren Wischvorgang
4. Exklusiver Trico-Verbinder - Zwei-Punkte-Ausführung sorgt für eine gleichmäßige Druckverteilung

FR Balais à montages multiples offrant d'excellentes performances

- Conçus pour être conformes aux pare-brises très incurvés actuels
- La technologie aérodynamique VorTec™ transforme la force du vent pour maximiser le contact sur le pare-brise à des vitesses allant jusqu'à 220 km/h (135 mph)
- HighGlide™ élément de caoutchouc traité assurant un balayage plus silencieux
- Adaptés à 96 % des véhicules avec un choix de seulement 20 modèles

1. Vor-Tec™ Défecteur - Défecteur à profil aérodynamique Spécialement conçu pour contrôler la turbulence de l'air et la transformer en pression d'essuie-glace
2. Système de connexion unique Trico - Convient à tous les bras d'essuie-glace d'origine actuels et aux bras à crochet traditionnels
3. Caoutchouc de formulation Trico - Caoutchouc traité HighGlide™ pour un balayage plus régulier et plus silencieux
4. Coupleur exclusif Trico - La conception à double point offre une répartition homogène de la pression

ES Escobillas Multi-fit (adaptación múltiple) de rendimiento óptimo

- Diseñadas para adaptarse a los parabrisas de gran curvatura actuales
- El perfil aerodinámico VorTec modifica la fuerza del viento para lograr el máximo contacto con el parabrisa a velocidades de hasta 220 km/h
- Goma tratada de deslizamiento superior para un barrido más silencioso
- Abarca el 96 % de los vehículos con solo 20 SKU

1. Alerón Vor-Tec™ - Alerón aerodinámico profundo diseñado específicamente para controlar las turbulencias de aire y convertirlas en presión para el limpiaparabrisas.
2. Sistema de conexión exclusivo de Trico - Se adapta a todos los brazos limpiaparabrisas modernos conocidos específicos de los EO y a los brazos con gancho tradicionales.
3. Goma formulada de Trico - Goma HighGlide™ tratada para lograr un barrido más suave y más silencioso.
4. Acoplamiento exclusivo de Trico - El diseño de dos puntos ofrece una distribución uniforme de la presión.

IT Spazzole multiuso dalle prestazioni eccezionali

- Progettate per adattarsi ai moderni parabrezza ad elevata curvatura.
- La lama d'aria VorTec™ converte la forza del vento in modo da garantire il contatto massimo sul parabrezza a velocità fino a 220 km/h.
- L'elemento in gomma trattato HighGlide™ garantisce un funzionamento più silenzioso.
- Adatte al 96% dei veicoli con soli 20 articoli a magazzino.

1. Spoiler Vor-Tec - Spoiler estremamente aerodinamico - progettato specificamente per controllare le turbolenze dell'aria e convertirle in pressione sulla spazzola
2. Sistema di raccordo Trico unico - Adatto a tutti i bracci di tergo cristalli specifici OE moderni e ai bracci tradizionali a gancio
3. Gomma dalla formulazione Trico esclusiva - Trattamento HighGlide™ della gomma per una pulizia più silenziosa e fluida
4. Attacco Trico esclusivo - Il design a due punti offre una distribuzione uniforme della pressione

PT Escovas de múltiplo encaixe com desempenho Premium

- Desenvolvidas em conformidade com os para-brisas modernos com curvatura acentuada
- O aerofólio VorTec converte a força do vento para o máximo contato do para-brisa a velocidades máximas de 220 km/h
- Componente de borracha tratada HighGlide para uma limpeza mais silenciosa
- Abrange 96% dos veículos com apenas 20 SKUs

1. Spoiler Vor-Tec - Spoiler altamente aerodinâmico desenvolvido especificamente para controlar a turbulência do ar e convertê-la em pressão das escovas limpa-vidros
2. Sistema de ligação exclusivo Trico - Encaixa em todos os braços de escovas limpa-vidros modernos e específicos mais vendidos e em braços com gancho tradicionais
3. Borracha formulada Trico - Tratamento de borracha HighGlide para uma limpeza mais suave e silenciosa
4. Acoplador exclusivo Trico - O design de ponto duplo oferece uma distribuição uniforme da pressão

NL Wissersbladen die op meerdere aansluitingen passen en hoogwaardige prestaties leveren

- Speciaal ontwikkeld om te voldoen aan de hedendaagse gewelfde voorruit
- Het VorTec-draagvlak converteert windkracht in maximaal contact met de voorruit met snelheden tot 220 kilometer per uur (135 mijl per uur)
- Met HighGlide behandeld rubberelement voor geruisloos wissen
- Past op 96% van de voertuigen met slechts 20 SKUs

1. Vor-Tec™ Spoiler - Diepe aerodynamische spoiler- Speciaal ontwikkeld voor beheersing van luchturbulentie en omzetting ervan in wisserdruk
2. Uniek Trico-aansluitingssysteem - Past op alle populaire, moderne, OE-specifieke wisserarmen en traditionele haakarmen
3. Trico geformuleerd rubber - HighGlide™ rubberbehandeling voor soepel, geruisloos wissen
4. Exclusieve Trico-koppeling - Ontwerp met twinpunten biedt gelijkmatige drukverdeling

NO Blader som kan tilpasses for førsteklasses ytelse

- Konstruert for å passe til dagens frontruter med stor bue
- VorTec aerofol konverterer vindkraft for maksimal kontakt med frontruten ved hastigheter opp til 220 km/t.
- Gummielmenter behandlet med HighGlide for vindusvisking som lager minimalt med lyd
- 96 % kjøretøysdekning fra bare 20 SKU-er

1. Vor-Tec™ spoiler - Dyp aerodynamisk spoiler Spesielt konstruert for å kontrollere turbulens og konvertere det til viskertrykk
2. Unikt Trico-tilkoblingssystem - Passer alle populære moderne OE-spesifikke viskerarme og tradisjonelle krokammer
3. Gummi av Trico-formel - HighGlide™-gummibehandling gir en mykere og stillere visker
4. Eksklusiv Trico-kobling - To-punks design gir jevn trykkfordeling

DK Blade med flere muligheder for montering for førsteklasses ydeevne

- Designet til at passe til moderne, yderst buede ruder
- Vor-Tec™ bærelan konverterer vindstyrke for maksimal kontakt med ruden ved hastigheder på op til 220 km/t
- HighGlide™ behandellet gummielment for en mere lydsvag visker
- 96 % køretøjer dækkes med blot 20 vareenheder

1. Vor-Tec™ spoiler - Dyb aerodynamisk spoiler Specialdesignet til at indfange luftturbulens og omdanne det til viskertryk
2. Unikt Trico-monteringsystem - Passer til alle populære moderne OE-spesifikke viskerarme og almindelige viskerarme med kroge
3. Trico-udformet gummi - HighGlide™-gummibehandling giver en mere jævn og lydsvag vinduesviskning
4. Eksklusiv Trico-muffe - Topknudsdesignet fordeler trykket jævnt

SE Högreprestande torkarblad som passar många typer av fästen

- Utformade för att passa dagens välvda vindrutor
- VorTec aerofol-tekniken omvandlar vindkraften och ger maximal kontakt med vindrutan i hastigheter upp till 220 km/h
- Gummibladet är behandlat med HighGlide för tytare torkning
- Endast 20 lagerplatsenheter täcker 96 % av alla fordonstyper

1. Vortecspoiler™ - Djup aerodynamisk spoiler –särskilt utformad för att kontrollera luftturbulens och omvandla den till torkartryck
2. Unikt Trico-anslutningssystem - Passar alla populära moderna originaldelspecifika torkarblad och traditionella krokamar
3. Trico-utformat gummi - HighGlide™-gummibehandling för jämnare, tytare torkning
4. Exklusiv Trico-koppling - Utformning med dubbla punkter ger jämn tryckfördelning

PL Pióra wycieraczek do różnego typu zastosowań o podwyższonej wydajności

- Stworzone z myślą o nowoczesnych wysoko profilowanych szybach przednich
- Profili lotniczy pióra VorTec wykorzystuje siłę wiatru do poprawy kontaktu z szybą przy prędkościach do 220 km/h
- Gumowy element HighGlide wpływa na wyciszenie pracy wycieraczek
- Zaledwie 20 SKU pasuje do 96% pojazdów

1. Spoiler Vor-Tec™ - Głęboki spoiler aerodynamiczny wykorzystuje siłę naporu powietrza w celu poprawy nacisku wycieraczki na szybę
2. Niepowtarzalny system złączeń Trico - Pasuje do wszystkich popularnych oryginalnych ramion wycieraczek i klasycznych ramion z mocowaniem hakowym
3. Formowanie gumy w technologii Trico - Obróbka gumy w technologii HighGlide™ gwarantuje bardziej płynne i ciche wycieranie
4. Unikatowa złączka Trico - Dwa punkty mocowania gwarantują równomiernie rozłożenie nacisku na szybę i

RU Высокоэффективные щетки Multi-Fit

- Разработаны для использования с современными сильно выпуклыми ветровыми стеклами
- Аэродинамический профиль VorTec™ использует силу ветра для обеспечения максимального контакта с поверхностью ветрового стекла на скоростях до 220 км/ч (135 миль/ч)
- Специально обработанный каучуковый элемент с высоким уровнем скольжения HighGlide для более тщательной очистки стекла
- Ассортимент всего из 20 номенклатурных позиций подходит для 96% автомобилей

1. Спойлер Vor-Tec™ - Спойлер с повышенными аэродинамическими качествами, разработанный специально для контроля завихрений потока воздуха и преобразования их в давление на стеклоочиститель
2. Уникальная система соединения Trico - Подходит для всех распространенных современных и традиционных рычагов стеклоочистителей с креплением типа «крючок»
3. Состав каучука от компании Trico - Специальная обработка каучукового элемента с высоким уровнем скольжения HighGlide™ для более равномерной и тщательной очистки стекла
4. Эксклюзивная соединительная муфта Trico - Двухточечная конструкция обеспечивает равномерное распределение давления

GR Μάκτρα πολλαπλής εφαρμογής, υψηλής απόδοσης

- Σχεδιασμένα ειδικά ώστε να είναι κατάλληλα για τα σημερινά παρμπριζ, υψηλής καμπυλότητας
- Το αντανεμικό φύλλο VorTec™ μετατρέπει τη δύναμη του αέρα για μέγιστη επαφή με το παρμπριζ, σε ταχύτητες έως 135 μ.μ.ω. (220 χ.μ.ω.)
- Ελαστικό στοιχείο με κατεργασία HighGlide, για πιο αθόρυβο σκούπισμα
- Κάλυψη του 96% των οχημάτων, μόλις από 20 SKU

1. Σπόιλερ Vor-Tec - Βαθύ αεροδυναμικό σπόιλερ ειδικά σχεδιασμένο για τον έλεγχο των στρόβιλισμών του αέρα και τη μετατροπή του σε πίεση υλοκαθαριστήρα
2. Μοναδικό σύστημα σύνδεσης Trico - Ταίριζει σε όλους τους δημοφιλείς σύγχρονους ειδικούς και παραδοσιακούς αγκιστρατούς βραχίονες προτύπου εζομπιακού
3. Καουτσούκ μορφοποιημένο από την Trico - Καουτσούκ με επεξεργασία HighGlide για ομαλότερο και πιο αθόρυβο σκούπισμα
4. Αποκλειστικός ζεύκτης Trico - Η σχεδίαση δύο σημείων προσφέρει ομοιομορφή κατανομή της πίεσης

IS Sérlega vönduð þurrkublöð fyrir margar gerðir bíla

- Sérhönnuð til að henta mjög bogadregnum framrúðum í nýlegri bílgerðum
- VorTec vængildið umbreytir vindhraðanum til að hámarka snertingu við framrúðu við allt að 220 km/klst. aksturhraða.
- Gúmmiengingin er meðhöndluð með HighGlide til að draga úr hljóði við notkun
- Aðeins þarf að eiga 20 gerðir á lager fyrir 96% ökutækja

1. Vor-Tec™ vindskeið - Mjög straumlínulöguð vindskeið Sérhönnuð til að vinna móti ökyrrð í lofti og umbreyta henni í þurrkublaðaprygting
2. Einstakt tengjakerfi Trico - Passar öllum vinsælustu gerðum nýlegra þurrkuarma með upprunalegri hönnun og hefðbundnum þurrkuörum með krókum
3. Mótað gummi frá Trico - Með HighGlide™ gúmmimehöndlun sem tryggir myki og hljóðlættari hreinsun
4. Sérhannað Trico-tengi - Tvöfaldrí prýstingspunktar jafna dreifingu prýstings

CZ Prémiové výkonné univerzální lišty

- Navrženy tak, aby vyhovovaly dnešním značně zaobleným předním skúm
- Profil VorTec převádí sílu větru za účelem dosažení maximálního kontaktu s čelním sklem při rychlosti až 220 km/h
- Tříšťi strání díky gumovému prvku upravenému pro vysoký skúz
- 96 % pokrytých vozidel pouhými 20 skladovými jednotkami

1. Spoiler Vor-Tec™ - Vysoce aerodynamický spoiler konstruovaný speciálně pro řízení vzdušných turbulencí a jejich přeměnu na tlak při stěru
2. Jedinečný spojovací systém Trico - Vhodný pro všechna oblíbená moderní ramena i klasická závesná ramena do originálních dílů
3. Guma vytvořená společností Trico - Ošetření gumy HighGlide™ zajišťuje plynulejší a rychlejší stěr
4. Exkluzivní spráhlo Trico - Dvoubodová konstrukce umožňuje rovnoměrné rozložení tlaku

FI Premium Performance Multi-Fit-pyyhkijänsulat

- Suunniteltu yhteensopiviksi nykykaisten erittäin kaarevien tuulilasién kanssa
- VorTec-kantopinta muuntaa tuulen voiman mahdollisimman tehokkaaksi tuulilasiäkosketukseksi jopa 220 kilometrin tuintinopeudessa
- Kästelty HighGlide-kumielementti pyyhkijän äänettömämmiin
- Vain 20 tuotekoodia kattaa 96 % ajoneuvosta

1. Vor-Tec™-ilmanohjain - Syvä, aerodynaaminen ilmanohjain - Suunniteltu erityisesti kontrolloimaan turbulenssia ja muuntaamaan sen pyyhkijöiden paineeksi
2. Ainutlaatuinen Trico-liitinjärjestelmä - Sopii kaikkiin suosituihin, nykyaikaisiin OE-spesifioituihin pyyhkijän varsiin ja perinteisiin koukkuvarsiin
3. Tricon kehittelämä kumi - HighGlide™-kumikäsitelty takaa tasaisemman ja äänettömämmän pyyhkimisen
4. Eriytyinen Trico-liitin - Kahden pisteen muotoilu takaa tasaisen paineen jakautumisen

EE Esmaklassilise tõhususega erinevate paigaldusvõimalustega klaasipuhasti harjad

- Valmistatud tänapäevastele suure kumerusega esiklaasidele
- VorTec aerodünaamiline kandepind esiklaasil peab vastu kokkupuutele tuulejõuga kiimust vähemalt kuni 135 miili tunnis (220 km/h)
- Toodeidud kummist HighGlide element vaiksemaks puhastamiseks
- Katab vajadusel 96% sõidukitel kõigest 20 laouhiku abil

1. Vor-Tec™ spoiler - Sügav aerodünaamiline spoiler – spetsiaalselt projekteeritud õhuturbulentsi ohjamiseks ja selle muutmiseks klaasipuhasti surveks
2. Unikaalne Trico ühendussüsteem - Sobib kõikide populaarsete kaasasete OE spetsifiliste klaasipuhasti hooabedega ja traditsiooniliste haakhooabedega
3. Trico spetsiaalse koostisega kumi - HighGlide™ kummitöötus sujuvamaks ja vaiksemaks klaasi puhastamiseks
4. Eksklusiivne Trico ühendus - Kahepunktiline konstruktsioon tagab ühtlase survejotuse

RO Lame de performanță superioară cu montare universală

- Proiectate pentru a fi compatibile cu parbrizele foarte curbate din prezent
- Aerofolia VorTec™ transformă forța vântului pentru un contact maxim cu suprafața parbrizului la viteze de până la 135 mile/h (220 km/h).
- Elementul din cauciuc tratat HighGlide™ pentru o ștergere mai silențioasă
- Acoperire de 96% a parcului de vehicule cu doar 20 de SKU-uri

1. Spoiler Vor-Tec - Spoiler aerodinamic profund - dezvoltat special pentru controlul turbulențelor și transformarea acestora în presiune a ștergătoarelor
2. Sistem de conexiune unic Trico - Este adecvat pentru toate ștergătoarele populare, moderne specifice, de tip echipament original, și toate brațele cu cârlig tradiționale
3. Cauciuc formulat Trico - Tratamente cu cauciuc HighGlide pentru o curățare mai fină, mai silențioasă
4. Sistem de cuplare exclusiv Trico - Designul dublu oferă distribuția uniformă a presiunii

SI Vrhunske zmogljive metlice z večnamenskim nastavkom

- Zasnovane tako, da ustrezajo današnjim zelo ukrivljenim vetrobranskim steklom
- Aerodinamični profil VorTec pretvori sunke vetra za maksimalni stik z vetrobranskim steklom do hitrosti 220 km/h (135 milj/h)
- Gumijasti element obdelan s tehnologijo HighGlide za tišje brisanje.
- 96 % pokritost vozil s samo 20 inventarnimi številkami

1. Spoiler Vor-Tec™ - Globok aerodinamičen spoiler - posebej zasnovan tako, da uravnava značno turbulenco in jo pretvori v pritisk brisalcev
2. Edinstven priključni sistem Trico - Prilega se vsem priljubljenim modernim nosilcem brisalcev, ki so specifični za originalno opremo, in tradicionalnim nosilcem s kavlji
3. Sestavljena guma Trico - Obdelava gume s tehnologijo HighGlide™ za bolj gladko in tišje brisanje
4. Ekskluzivna spojka Trico - Dvočtočkova zasnova zagotavlja enakomerno porazdelitev pritiska

TRICO Force®



Premium performance multi-fit beam blades.



- Engineered to conform to today's highly curved windscreens
- VorTec™ aerofoil converts wind force for maximum windscreen contact at speeds up to 135mph (220kph)
- HighGlide™ treated rubber element for a quieter wipe
- 96% vehicle coverage from just 20 SKU's
- Available in lengths from 350mm to 800mm



① Vor-Tec™ Spoiler

Deep aerodynamic spoiler-
Specifically engineered to
control air turbulence &
convert it to wiper pressure

② Unique Trico Connection System

Fits all popular modern OE specific
wiper arms & traditional hook arms

③ Trico Formulated Rubber

HighGlide™ rubber treatment
for a smoother, quieter wipe

④ Exclusive Trico Coupler

Twin point design offers even
pressure distribution



DE Fortschrittliche Beam-Blade-Technologie für jedermann.

- Dank dem modernsten Beam-Blade-Design ist die neueste Wischtechnologie jetzt für alle Fahrzeugtypen erhältlich
- Wischerblatt aus Stahl mit Formgedächtnis sorgt für gleichmäßigen Druck und somit für ein sauberes, streifenfreies Wischergebnis
- Abdeckung von 97 % aller Fahrzeuge mit nur 14 Lagerposten
- Passend für alle beliebten OE-Beam-Wischerarme und zur Aufrüstung von Standardwischerarmen auf Beam-Blade-Technologie

1. Symmetrischer Spoiler - Symmetrischer Spoiler sorgt für eine bessere Windabwägung und ermöglicht eine Montage an LHR- und RHD-Wischerarmen
2. Einzigartiges Trico-Verbindungssystem - Passend für alle beliebten modernen Originalteil-spezifischen Wischerarme und Standardhakenwischerarme
3. Gummi nach Trico-Rezeptur - Einzigartiges Originalteil nach Zweikomponenten-Rezeptur
4. Exklusiver Trico-Verbinder - Zwei-Punkte-Ausführung sorgt für eine gleichmäßige Druckverteilung

FR Technologie de pointe des balais à profil aérodynamique pour tous.

- Balais d'essuie-glace au design actuel offrant la toute dernière technologie d'essuie-glace pour tous les types de véhicule
- Le profil aérodynamique du balai Memory Curve Steel assure une pression uniforme pour un balayage propre et net
- 14 modèles seulement couvrant 97 % du parc automobile
- Convient à tous les bras d'essuie-glace à profil aérodynamique d'origine de marque connue et adaptation des bras traditionnels à la technologie aérodynamique

1. Déflecteur symétrique - Le déflecteur symétrique permet de réduire le soulèvement du balai sous l'action du vent et permet le montage des systèmes d'essuie-glace à gauche et à droite
2. Système de connexion unique Trico - Convient à tous les bras d'essuie-glace d'origine actuels et aux bras à crochet traditionnels
3. Trico Formulated Rubber - Unique Trico dual material OE formulation
4. Exclusive Trico Coupler - Twin point design offers even pressure distribution

ES Tecnología avanzada en escobillas flexibles al alcance de todos.

- Escobilla flexible de diseño moderno que ofrece la tecnología más avanzada en limpiaparabrisas para todo tipo de vehículos
- Perfil de acero curvo con memoria que proporciona presión uniforme para un barrido limpio y claro
- Sólo 14 SKU que abarcan el 97 % del parque automotor
- Se adapta a todos los brazos limpiaparabrisas flexibles de EO y sirve para sustituir los brazos convencionales por la tecnología flexible más moderna

1. Alerón simétrico - El alerón simétrico reduce la elevación por el efecto del viento y puede instalarse en los sistemas limpiaparabrisas de vehículos con volante a la derecha (right-hand drive, RHD) y con volante a la izquierda (left-hand drive, LHD).
2. Sistema de conexión exclusivo de Trico - Se adapta a todos los brazos limpiaparabrisas modernos y conocidos específicos de los EO y a los brazos con gancho tradicionales.
3. Goma formulada de Trico - Formulación doble de materiales de los EO exclusiva de Trico.
4. Acoplamiento exclusivo de Trico - El diseño de dos puntos ofrece una distribución uniforme de la presión.

IT Tecnologia avanzata per spazzole adatte a tutti.

- Spazzole per tergicristalli dal design moderno dotate della tecnologia dei tergicristalli più recente adatta a ogni tipo di veicolo.
- La spazzola Memory Curve Steel garantisce una pressione uniforme e quindi un funzionamento pulito ed efficace.
- Sono necessari solo 14 articoli a magazzino per coprire il 97% del parco veicoli.
- Adatta a tutti i bracci dei tergicristalli a spazzola piatta OE più diffusi e per l'aggiornamento dei bracci tradizionali alla tecnologia a spazzole piatte.

1. Spoiler simmetrico - Lo spoiler simmetrico riduce il carico del vento e può essere montato nei sistemi di tergicristalli sia per guida a destra che per guida a sinistra
2. Sistema di raccordo Trico unico - Adatto a tutti i bracci di tergicristalli specifici OE moderni e ai bracci tradizionali a ganccio
3. Gomma dalla formulazione Trico esclusiva - Formulazione OE esclusiva Trico in materiale doppio
4. Attacco Trico esclusivo - Il design a due punti offre una distribuzione uniforme della pressione

PT Tecnologia avançada de escovas planas para todos.

- As escovas planas de design moderno oferecem a última tecnologia de escovas para todos os tipos de veículos
- O braço Memory Curve Steel proporciona uma pressão uniforme para uma limpeza profunda e eficaz
- Apenas 14 SKUs abrangem 97% do parque automóvel
- Adequado para os braços de escovas limpa-vidros planas originais mais vendidas e indicado para substituir os braços convencionais pela tecnologia de escovas planas

1. Spoiler simétrico - O spoiler simétrico reduz a elevação pelo vento e permite o encaixe em sistemas de escovas limpa-vidros de veículos com volante do lado esquerdo ou direito
2. Sistema de ligação exclusivo Trico - Encaixa em todos os braços de escovas limpa-vidros modernos e específicos mais vendidos e em braços com gancho tradicionais
3. Borracha formulada Trico - Formulção exclusiva de duplo material original da Trico
4. Acoplador exclusivo Trico - O design de ponto duplo oferece uma distribuição uniforme da pressão

NL Geavanceerde draagbladtechnologie voor iedereen.

- Het draagblad, dat een modern ontwerp heeft, voorziet alle voertuigsoorten van de meest recente wisserstechnologie
- Het stalen blad met geheugencurve levert gelijkmatige druk voor een schone, doorzichtige wisbeweging
- Slechts 14 SK's nodig om 97% van alle voertuigen van de wisser te voorzien
- Geschikt voor alle veelgebruikte OE-bladwisserarmen en als upgrade van conventionele armen naar draagbladtechnologie

1. Symmetrische spoiler - Symmetrische spoiler reduceert optillen door de wind en zorgt dat linker- en rechterwisserarmen passen
2. Uniek Trico-aansluitingssysteem - Past op alle populaire, moderne, OE-specifieke wisserarmen en traditionele haakarmen
3. Trico geformuleerd rubber - Uniek Trico uit twee materialen bestaande OE-formulering
4. Exclusieve Trico-koppeling - Ontwerp met twinpunten biedt gelijkmatige drukverdeling

NO Avansert bombladteknologi for alle.

- Bomblad av moderne design som leverer den nyeste vindviskerteknologien til alle kjøretøytyper
- Memory Curve-stålarm leverer enhetlig trykk for vindvisking som gir en ren, klar rute
- Bare 14 SKU-er for å dekke 97 % av kjøretøyparken
- Passer til alle populære OE-vindviskeramer med bom og til oppgradering av vanlige armer til bomteknologi

1. Symmetrisk spoiler - Symmetriske spoilere reduserer vindbelastningen og kan tilpasse både LHD- og RHD-viskersystemer
2. Unikt Trico-tilkoblingssystem - Passer alle populære moderne OE-spesifikke viskeramer og tradisjonelle krokammer
3. Gummi av Trico-formel - Unik Trico-dobbelmateriale OE-sammensetning
4. Eksklusiv Trico-kobling - To-punkts design gir jevn trykkfordeling

DK Avanceret flatblade-teknologi til alle.

- Moderne designet flatblade forsyner alle køretøjstyper med den nyeste viskerteknologi
- Memory Curve Steel-bjælke giver ensartet tryk for ren, tydelig viskning
- Kun 14 vareenheder for at dække 97 % af vognparken
- Egnet til alle populære originaludstyr flatblade-viskerarme og opgradering af konventionelle arme til flatblade-teknologi

1. Symmetrisk spoiler - Den symmetriske spoiler reducerer vindløft og gør det muligt at montere både LHD- og RHD-vindviskere
2. Unik Trico-monteringsystem - Passer til alle populære moderne OE-spesifikke viskeramer og almindelige viskeramer med kroge
3. Trico-udformet gummi - Unik Trico-dobbelmateriale med OE-udformning
4. Eksklusiv Trico-muffe - Topunktsdesignet forleder trykket jævnt

SE Avancerad bygelöst teknik för alla.

- Bygelösa torkarblad i modern design ger den senast torkarbladstekniken för alla fordonstyper
- Memory Curve Steel-fjäder ger ett jämnt tryck och en ren och klar torkning
- Endast 14 lagerplatsenheter täcker 97 % av alla fordonstyper
- Passar alla populära originaltillverkade bygelösa torkararmar och uppgraderar konventionella torkararmar till bygelöst teknik

1. Symmetrisk spoiler - Symmetrisk spoiler minskar vindlyft och möjliggör montering på torkningsystem för både vänster- och högertrafik
2. Unik Trico-anslutningssystem - Passar alla populära moderna originaldelspecifika torkarblad och traditionella krokarmar
3. Trico-utformat gummi - Unik Trico-dubbelmaterial med originaldelsutformning
4. Exklusiv Trico-koppling - Utformning med dubbla punkter ger jämnt tryckfördelning

PL Zaawansowane technologicznie pióra płaskie dla każdego

- Nowoczesne pióra płaskie to najnowsza technologia wycierania do wszystkich rodzajów pojazdów
- Stalowe pióra płaskie Memory Curve gwarantują czystość i przejrzystość szyby dzięki jednokowej sile nacisku
- Zaledwie 14 SKU pasuje do 97% pojazdów
- Pasuje do wszystkich najpopularniejszych oryginalnych ramion wycieraczek płaskich i nadaje się do montażu na ramionach klasycznych

1. Spoiler symetryczny - Spoiler symetryczny redukuje efekt unoszenia się wycieraczki i umożliwia mocowanie zarówno do układow lewo- jak i prawostronnych
2. Niepowtarzalny system złączeń Trico - Pasuje do wszystkich popularnych oryginalnych ramion wycieraczek i klasycznych ramion z mocowaniem hakowym
3. Formowanie gumy w technologii Trico - Wycieraczki formowane z oryginalnej dwuskładnikowej mieszanki Trico
4. Unikutowa złączka Trico - Dwa punkty mocowania gwarantują równomiernie rozłożenie nacisku na szybę

RU Передовая бескаркасная технология подходит всем.

- В современных бескаркасных щетках используется новейшая технология стеклоочистки, подходящая для всех типов транспортных средств
- Бескаркасная конструкция по технологии "запоминания" изгиба стекла Memory Curve Steel обеспечивает равномерный прижим и идеально чистую стekла
- Всего 14 номенклатурных позиций подходят для 97% автомобилей
- Подходит для всех оригинальных рычагов бескаркасных щеток, а также для усовершенствования классических рычагов в соответствии с бескаркасной технологией

1. Симметричный спойлер - Симметричный спойлер снижает подъемную силу ветра и позволяет осуществлять установку как на леворульные, так и на праворульные автомобили
2. Уникальная система соединения Trico - Подходит для всех распространенных современных и традиционных рычагов стеклоочистителей с креплением типа «крючок»
3. Состав каучука от компании Trico - Уникальный двойной состав материала от производителя Trico
4. Эксклюзивная соединительная муфта Trico - Двухточечная конструкция обеспечивает равномерное распределение давления

GR Εξελιγμένη τεχνολογία μονοκόμματων μάκτρων για όλους.

- Μονοκόμματο μάκτρο σύγχρονης σχεδίασης που αποδίδει την πιο πρόσφατη τεχνολογία υαλοκαθαριστήρων για όλους τους τύπους οχημάτων
- Μονοκόμματα σχεδίαση από χάλυβα με καμπυλότητα μίνιμαξ αποδίδει ομοιόμορφη πίεση για καθαρό, διαυές καθάρισμα
- Μόνο 14 SKU καλύπτουν 97% του στόλου των οχημάτων
- Κατάλληλο για όλους τους δημοφιλείς βραχίονες μονοκόμματων υαλοκαθαριστήρων κατασκευαστών τυπικού εξοπλισμού και για την αναβάθιση συμβατικών βραχίονων στην τεχνολογία μονοκόμματης σχεδίασης

1. Συμμετρικό σπόιλερ - Το συμμετρικό σπόιλερ μειώνει την ανύψωση από τον αέρα και επιτρέπει την τοποθέτηση σε συστήματα και με αριστερό και με δεξίο υαλοκαθαριστήρα
2. Μοναδικό σύστημα σύνδεσης Trico - Ταίριαζει σε όλους τους δημοφιλείς σύγχρονους ειδικούς και παραδοσιακούς βραχίονες πρωτότυπου εξοπλισμού
3. Καουτσούκ μορφοποιημένο από την Trico - Μοναδική σύνθεση πρωτότυπου εξοπλισμού διπλού υλικού
4. Αποκλειστικός ζεύκτης Trico - Η σχεδίαση δύο σημείων προσφέρει ομοιόμορφη κατανομή της πίεσης

IS Hápróuð þurrkublaðatekni fyrir alla.

- Þurrkublað með nútímalegri hönnun sem tryggir nýjustu tækni í þurrkublaðum fyrir allar gerðir bíla
- Þurrkublaðaurm úr Memory Curve-stáli tryggir jafnan þrýsting og gerir þurrkunina jafna og góða
- Aðeins þarf að eiga 14 gerðir á lager fyrir 97% ökutækja
- Hentar á alla vinslustu þurrkublaðamana af upprunalegum gerðum og uppferða, hefðbundna arma

1. Samhverf vindskíð - Samhverf vindskíð dregur úr vindmótstöðu og gefur færi á að festa blaðið við bæði LHD- og RHD-rúðuþurrkerfi
2. Einstakt tengjakerfi Trico - Passar öllum vinslustu gerðum nýlegra þurrkublaða með upprunalegri hönnun og hefðbundnum þurrkublaðum með krókum
3. Mótátt gúmmi frá Trico - Einstakt tvískipt Trico-efni Upprunaleg mótun
4. Sérhannað Trico-tengi - Tvöfaldir þrýstingspunktur jafna dreifingu þrýstings

CZ Pokročilá technologie listů stěračů pro každého.

- Moderní design listů stěračů, s nimiž mohou nejnovější stráci technologie využívat všechny typy vozidel.
- Ocelový stěrač s paměťovým zakřivením zajišťuje rovnoměrný tlak a kvalitní strání
- Pouze 14 skladových jednotek pokrývá 97 % vozového parku
- Vhodné pro všechny oblíbené originální nosiče stěračů i vylepšení tradičních nosičů na bezramíkovou technologii

1. Symetrický spoiler - Symetrický spoiler snižuje vztlak větru a umožňuje zapojení do systému levého i pravého předního stěrače
2. Jediný spojovací systém Trico - Vhodný pro všechna oblíbená moderní ramena stěračů i klasická závesná ramena do originálních dílů
3. Guma vytvořená společností Trico - Jediný dvousložkový materiál Trico pro originální díly
4. Exkluzivní spráho Trico - Dvoubodová konstrukce umožňuje rovnoměrné rozložení tlaku

FI Kehittynyt rungoton pyyhkiänsulkateknikka kaikille.

- Nykykäitaisesti suunniteltu rungoton pyyhkiänsulka tuo viimeisimmän tuuliyksityyhinteknologian kaikkiin ajoneuvotyyppeihin
- Rungoton Memory Curve Steel -pyyhkiänsulan yhdenmukainen paine tuottaa siistin ja puhtaan pyyhkimisjäljen
- Vain 14 tuotekoodia kattaa 97 % ajoneuvosta
- Sopii kaikkiin suosituihin, rungottomiin alkuperäisvalmistajien pyyhkinvarsin ja perinteisten pyyhkinvarsin muuntamiseen rungotton sulkateknikan käyttöön

1. Symmetrinen ilmanohjain - Symmetrinen ilmanohjain vähentää tuulen nostetta ja voidaan asentaa niin vasemman- kuin oikeanpuoleisen ohjauksen pyyhkiänsuljestelmiin
2. Ainutlaatuinen Trico-liitinjärjestelmä - Sopii kaikkiin suosituihin, nykykäitisiin OE-spesifioituhiin pyyhkiänsulkin varsin ja perinteisiin koukkuvarsiin
3. Tricon kehittelämä kumi - Ainutlaatuinen Tricon kahden materiaalin OE-muottili
4. Eriytyinen Trico-liitin - Kahden pisteen muottili takaa tasaisen paineen jakautumisen

EE Raamiga klaasipuhasti harjade täiustatud tehnoloogia igale kliendile.

- Kaasaegse konstruktsiooniga raamiga hari – moderne klaasipuhastitehnoloogia kõikidele sõidukitüüpidele
- Memory Curve Steel raam tagab klaasi puhastamisest ühtlase surve
- Ainult 14 laotühikut katab vajaduse 97% sõidukitel
- Sobiv kõigile levinud OE raamiga klaasipuhasti hoobadele ning tavapärase hoobade muutmiseks raamitehnoloogiaga hoobadeks

1. Sümmetriline spooler - Sümmetriline spooler vähendab tuuletõstet ja võimaldab ühendada nii LHD kui ka RHD klaasipuhasti süsteemid
2. Unikaalne Trico ühendussüsteem - Sobib kõikidele populaarsele kaasaegsetele OE-spesifilistele klaasipuhastitehnoloogiaga ja traditsioonilistele haakhoobadele
3. Trico spetsiaalne koostisega kummi - Unikaalne Trico kahekomponentiline materjal OE koostis
4. Eksklusivne Trico ühendus - Kahepunktiline konstruktsioon tagab ühtlase survejootuse

RO Tehnologie avansată cu lamă fără cadru pentru toată lumea.

- Lama fără cadru cu design modern oferă cea mai nouă tehnologie de ștergere pentru toate tipurile de vehicule
- Designul fără cadru Memory Curve Steel asigură presiune uniformă pentru o ștergere curată și fără urme
- Doar 14 SKU-uri pentru a acoperi 97% din parcul de vehicule
- Adecvat pentru toate brațele populare de ștergător fără cadru de tip echipament original și modernizarea brațelor convenționale la tehnologia fără cadru

1. Spoiler simetric - Spoilerul simetric reduce portanța și permite fixarea pe ambele sisteme de ștergătoare LHD și RHD
2. Sistem de conexiune unic Trico - Este adecvat pentru toate ștergătoarele populare, moderne specifice, de tip echipament original, și toate brațele cu cârlig tradiționale
3. Cauciuc formulat Trico - Formulare unică Trico, de tip echipament original, cu material dublu
4. Sistem de cuplare exclusiv Trico - Designul dublu oferă distribuția uniformă a presiunii

SI Napredna tehnologija metlic za vsakogar.

- Sodobna oblika metlice omogoča najnovejšo tehnologijo za brisanje za vse tipe vozil.
- Metlica s tehnologijo »Memory Curve Steel« omogoča enakomeren stik s površino za temeljito brisanje
- Samo 14 inventarnih števil pokriva 97 % voznega parka
- Primerno za vse priljubljene ročice za brisanje s ploškimi metlicami OE in nadgradnjo konvencionalnih ročic s ploško tehnologijo

1. Simetrični spooler - Simetrični spooler zmanjšuje vetrni upor ter omogoča namestitev na sisteme brisalcev pri vozilih z volanom na levi in na desni strani
2. Edinstven priključni sistem Trico - Prilega se vsem priljubljenim modernim nosilec brisalcev, ki so specifični za originalno opremo, in tradicionalnim nosilec s kavlji
3. Sestavljena guma Trico - Edinstvena sestava kot originalna oprema Trico iz dvojnega materiala
4. Ekskluzivna spojka Trico - Dvotočkovna zasnova zagotavlja enakomere porazdelitev pritiska



Advanced beam blade technology for everyone.

- Modern design beam blade giving the latest wiper technology for all vehicle types
- Memory Curve Steel beam provides uniform pressure for a clean, clear wipe
- Only 14 SKU's to cover 97% of the vehicle parc
- Suitable for all popular OE beam wiper arms, & upgrading conventional arms to beam technology
- Available in lengths from 350mm to 800mm



- ① Symmetrical Spoiler**
Symmetrical spoiler reduces windlift & allows fitment to both LHD & RHD wiper systems

- ② Unique Trico Connection System**
Fits all popular modern OE specific wiper arms & traditional hook arms

- ③ Trico Formulated Rubber**
Unique Trico dual material OE formulation

- ④ Exclusive Trico Coupler**
Twin point design offers even pressure distribution

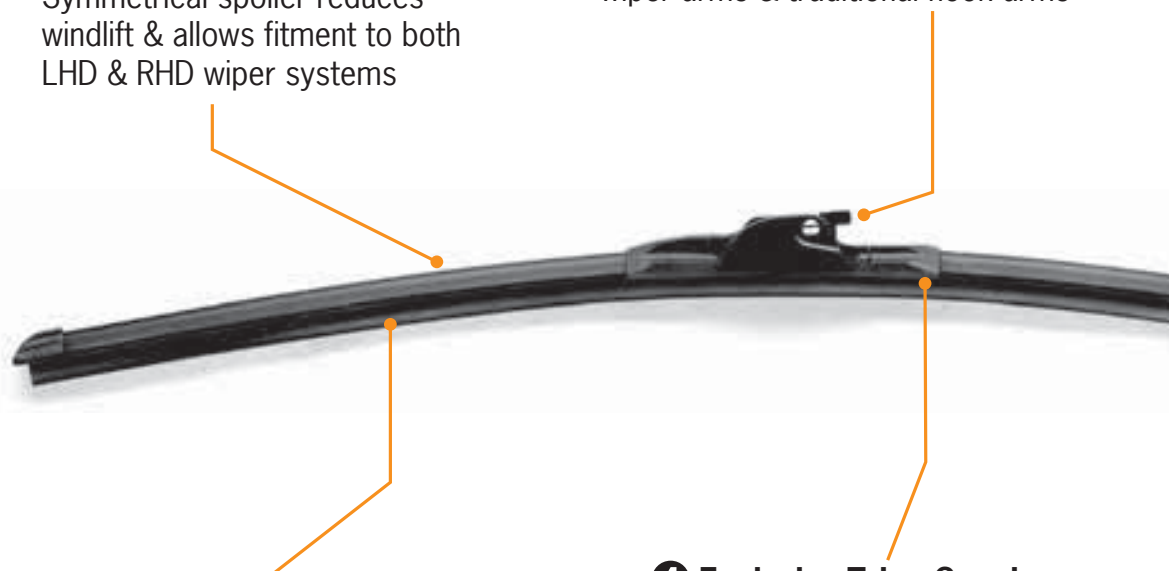

DE Rüsten Sie jetzt auf die neue Beam-Blade-Technologie auf.

- Beam-Wischerblätter zum Nachrüsten, um herkömmliche Wischerblätter auf den Stand der neuesten Fahrzeugtechnologie zu bringen
- Bietet bessere Allwetter-Leistung und eine höhere Lebensdauer
- Schnelle & einfache Montage
- Auch zur Direktmontage an Original-Verbindern verfügbar

1. Symmetrischer Spoiler - Symmetrischer Spoiler sorgt für eine bessere Windabweisung und ermöglicht eine Montage an LHR- und RHD-Wischersystemen
2. Patentierter Trico-Universal-Verbinder - Sicherer Halt an allen Haakenwischerarmen mit den Abmessungen 9 x 3 mm & 9 x 4 mm
3. Gummi nach Trico-Rezeptur - Einzigartiges Originalteil nach Zweikomponenten-Rezeptur
4. Beam-Ausführung mit einzelner Keilnut - Stufenlose Druckpunkte sorgen für eine gleichmäßige Druckverteilung über die gesamte Länge des Wischerblatts
5. Exklusiver Trico-Verbinder - Zwei-Punkte-Ausführung sorgt für eine gleichmäßige Druckverteilung

FR Adaptation à la toute dernière technologie de balais d'essuie-glace à profil aérodynamique.

- Balai à profil aérodynamique de remplacement pour adapter les essuie-glace traditionnels à la toute dernière technologie du véhicule
- Offre une performance supérieure par tous les temps et une meilleure durabilité
- Rapidité et facilité d'installation
- Également disponible avec des connexions d'origine, à montage direct

1. Défecteur symétrique - Le défecteur symétrique permet de réduire le soulèvement du balai sous l'action du vent et de défectuer le montage des systèmes d'essuie-glace à gauche et à droite
2. Connecteur universel Trico breveté - Permet de sécuriser le montage de tous les bras d'essuie-glace à crochet 9 x 3 mm et 9 x 4 mm
3. Caoutchouc de formulation Trico - Double matériau unique Trico Formulation d'origine
4. Conception à profil aérodynamique à une seule ventrière - Offre d'innombrables points de pression pour une répartition homogène de la pression sur toute la longueur du balai
5. Coupleur exclusif à Trico - La conception à double point offre une répartition homogène de la pression

ES Modernícese y utilice la última tecnología en escobillas limpiaparabrisas flexibles.

- Modernícese con las escobillas flexibles y sustituya los limpiaparabrisas convencionales por la última tecnología para vehículos
- Ofrecen un rendimiento superior en todas las condiciones climáticas y una mayor durabilidad
- De instalación fácil y rápida
- También se comercializan con las conexiones de instalación directa de los EO

1. Alerón simétrico - El alerón simétrico reduce la elevación por el efecto del viento y puede instalarse en los sistemas limpiaparabrisas de vehículos con volante a la derecha (right-hand drive, RHD) y con volante a la izquierda (left-hand drive, LHD).
2. Goma formulada de Trico - Formulación doble de materiales de los EO exclusiva de Trico.
3. Diseño flexible de chaveta única - Ofrece puntos de presión infinitos para proporcionar una distribución uniforme de la presión en toda la longitud de la escobilla.
4. Acoplamiento exclusivo de Trico - El diseño de dos puntos ofrece una distribución uniforme de la presión.

IT Aggiornamento alla tecnologia più recente di tergicristalli a spazzola piatte.

- Tergicristalli a spazzola piatta per installazione successiva per l'aggiornamento dei tergicristalli tradizionali alla tecnologia più recente.
- Offre prestazioni superiori in qualsiasi condizione meteorologica e maggiore durata.
- Installazione rapida e semplice
- Disponibile anche con raccordi di tipo OE con montaggio diretto.

1. Spoiler simmetrico - Lo spoiler simmetrico riduce il carico del vento e può essere montato nei sistemi di tergicristalli sia per guida a destra che per guida a sinistra
2. Connettore universale Trico brevettato - Montaggio sicuro in tutti i bracci di tergicristalli a gancio da 9x3 mm e 9x4 mm
3. Gomma dalla formulazione Trico esclusiva - Formulazione OE esclusiva Trico in materiale doppio
4. Spazzola piatta con scanalatura singola - Offre punti di pressione infiniti per una distribuzione uniforme della pressione per l'intera lunghezza della spazzola
5. Attacco Trico esclusivo - Il design a due punti offre una distribuzione uniforme della pressione

PT Substitua pela última tecnologia de escovas limpa-vidros planas.

- Escovas de limpa-vidros planas como acessório para substituir as escovas convencionais pela última tecnologia automóvel
- Oferece um desempenho superior em todas as condições climáticas e uma maior durabilidade
- Colocação simples e rápida
- Também disponível com ligações de encaixe direto do tipo equipamento original

1. Spoiler simétrico - O spoiler simétrico reduz a elevação pelo vento e permite o encaixe em sistemas de escovas limpa-vidros de veículos com volante do lado esquerdo ou direito
2. Conector universal patenteado Trico - Encaixe seguro em todos os braços de escovas limpa-vidros com gancho de 9 x 3 mm e 9 x 4 mm
3. Borracha formulada Trico - Formulação exclusiva de duplo material original da Trico
4. Design de escovas limpa-vidros planas com veio único - Oferece infinitos pontos de pressão para uma distribuição uniforme da pressão em toda a extensão das escovas
5. Acoplador exclusivo Trico - O design de ponto duplo oferece uma distribuição uniforme da pressão

Upgrade naar de meest recente technologie voor draagbladwissers.

- Breng nieuwe draagbladwissers aan als upgrade van conventionele wissers naar de meest recente voertuigtechnologie
- Biedt superieure prestaties onder alle weersomstandigheden en verbeterde duurzaamheid
- Snel en gemakkelijk te installeren
- Ook beschikbaar met direct aan te brengen OE-connectors

1. Symmetrische spoiler - Symmetrische spoiler reduceert optillen door de wind en zorgt dat linker- en rechterwischersystemen passen
2. Gepatenteerde Trico universele connector - Stevige pasvorm op alle haakwischerarmen van 9x3 mm & 9x4 mm
3. Trico geformuleerd rubber - Uniek Trico uit twee materialen bestaande OE-formulering
4. Ontwerp met enkelvoudige spiebaandraagma - Biedt oneindige drukpunten voor evenredige drukverdeling over de volledige lengte van het blad
5. Exclusieve Trico-koppeling - Ontwerp met twinpunten biedt gelijkmatige drukverdeling

NO vindusviskerblad med bom.

- Ettermonteret blader for å oppgradere vindueviskerve til det aller nyeste innen kjøretøyteknologi
- Tilbyr forbedret varighet og overlegen ytelse i alle typer vær
- Raske og enkle å installere
- Også tilgjengelig med koblinger av OE-type med direktekobling

1. Symmetrisk spoiler - Symmetriske spoilere reduserer vindbelastningen og kan tilpasses både LHD- og RHD-viskersystemer
2. Patentert universell tilkobling fra Trico - Sikker tilpasning til alle 9x3 og 9x4 mm viskerarmer med krokfester
3. Gummi av Trico-formel - Unik Trico-dobbelmateriale OE-sammensetning
4. En enkelt skinn i flat utforming - Gir uendelig mange trykkpunkter og jevn trykkfordeling over hele bladlengden
5. Eksklusiv Trico-kobling - To-punkts design gir jevn trykkfordeling

DK Opgrader til den nyeste flatblade-viskerbladteknologi.

- Eftermonteret flatblade for at opgradere konventionelle viskere til den allernyeste køretøjs-teknologi
- Giver overlegen ydeevne i al slags vejr samt forbedret holdbarhed
- Hurtig og let at installere
- Kan også fås med originaludstyrsforbindelsesstykker til direkte montering

1. Symmetrisk spoiler - Symmetriske spoilere reduserer vindbelastningen og kan tilpasses både LHD- og RHD-viskersystemer
2. Patentert universell tilkobling fra Trico - Sikker tilpasning til alle 9x3 og 9x4 mm viskerarmer med krokfester
3. Gummi av Trico-formel - Unik Trico-dobbelmateriale OE-sammensetning
4. En enkelt skinn i flat utforming - Gir uendelig mange trykkpunkter og jevn trykkfordeling over hele bladlengden
5. Eksklusiv Trico-kobling - To-punkts design gir jevn trykkfordeling

SE Uppgradera till den senaste bygelåsa torkarbladstekniken.

- Bygelåsa torkarblad med äldre passform för uppgradering av konventionella torkarblad till den allra senaste fordonstekniken
- Ger överlägsen prestanda i alla väder typer och längre hållbarhet
- Snabb och enkel att montera
- Finns även med direktpassande fästen för originaldelar

1. Symmetrisk spoiler - Symmetrisk spoiler minskar vindlyft och möjliggör montering på torkningsystem för både vänster- och högertrafik
2. Patenterad Trico-universalanslutare - Säker montering till alla torkarblad med krok på 9x3 mm och 9x4 mm
3. Trico-utformat gummi - Unik Trico-dubbelmaterial med originaldelutformning
4. Bygelås utformning med enkel spline - En mängd tryckpunkter för jämn tryckfördelning över hela bladet
5. Exklusiv Trico-koppling - Utformning med dubbla punkter ger jämn tryckfördelning

PL Wybierz najnowszą technologię wycieraczek płaskich

- Mocowanie pióra płaskiego na ramionach klasycznych umożliwia korzystanie z najnowszej technologii wycierania
- Produkt charakteryzuje najwyższa wydajność w każdych warunkach i zwiększona trwałość
- Szybki i prosty montaż
- Dostępne również ze złączami oryginalnymi do mocowania bezpośredniego

1. Spoiler symetryczny - Spoiler symetryczny redukuje efekt unoszenia się wycieraczki i umożliwia mocowanie zarówno do układów lewo- jak i prawostronnych
2. Uniwersalna patentowana złączka Trico - Pewne mocowanie do wszystkich wycieraczek z uchwytem hakowym 9mm x 3m i 9mm x 4mm
3. Formowanie gumy w technologii Trico - Wycieraczki formowane z oryginalnej dwuskładnikowej mieszanki Trico
4. Pióro płaskie z rdzeniem pojedynczym - Dzięki nieskończonej ilości punktów nacisku uzyskano równomierny rozkład nacisku na szybie na całej długości pióra
5. Unikutowa złączka Trico - Dwa punkty mocowania gwarantują równomierne rozłożenie nacisku na szybie

RU Совершенствование в соответствии с новейшей технологией бескаркасных щеток.

- Бескаркасная щетка Retro-Fit для совершенствования классических стеклоочистителей в соответствии с новейшей технологией
- Обеспечивает превосходную эффективность и повышенную прочность в любых погодных условиях
- Быстрая, простая установка
- Также доступна в комплекте с оригинальными соединениями с предусмотренными адаптерами

1. Симметричный спойлер - Симметричный спойлер снижает подъемную силу ветра и позволяет осуществлять установку как на леворульные, так и на праворульные автомобили
2. Запатентованное универсальное крепление Trico - Безопасное крепление на все стеклоочистители с креплением типа «крючок» размером 9x3мм и 9x4мм
3. Состав каучука от компании Trico - Уникальный двойной состав материала от производителя Trico
4. Бескаркасная конструкция со шлицевым соединением с одной шпонкой Обеспечивает множество центров давления для его равномерного распределения по всей длине щетки
5. Эксклюзивная соединительная муфта Trico - Двухточечная конструкция обеспечивает равномерное распределение давления

GR Κάνετε αναβάθμιση στην τελευταία τεχνολογία μονοκόμματων μακτρών υαλοκαθαριστήρων.

- Μονοκόμματο μακτρό μεταγενέστερης τοποθέτησης για την αναβάθμιση των συμβατικών υαλοκαθαριστήρων στην τελευταία τεχνολογία αυτοκινήτου
- Προσφέρει βελτιωμένη απόδοση σε όλες τις καιρικές συνθήκες και βελτιωμένη ανθεκτικότητα
- Γρήγορη και εύκολη τοποθέτηση
- Διατίθεται επίσης με συνδέσμους άμεσης τοποθέτησης, τύπου πρωτότυπου εξοπλισμού

1. Συμμετρικό σπόιλερ - Το συμμετρικό σπόιλερ μειώνει την ανύψωση λόγω αέρα και επιτρέπει την τοποθέτηση σε συστήματα και με αριστερό και με δεξιό υαλοκαθαριστήρα
2. Κατοχυρωμένος σύνδεσμος γενικής χρήσης Trico - Σταθερή τοποθέτηση σε όλους τους αριστοτεχνικούς βραχίονες υαλοκαθαριστήρων 9x3 mm και 9x4 mm
3. Καουτσόκ μορφοποιημένο από την Trico - Μοναδική σύνθεση Trico πρωτότυπου εξοπλισμού υαλοκαθαριστήρα
4. Μονοκόμματο σχεδίαση με μονό άξονα - Προσφέρει άπειρα σημεία πίεσης για ομοιόμορφη κατανομή της πίεσης σε όλο το μήκος του μακτρου
5. Αποκλειστικός ζεύκτης Trico - Η σχεδίαση δύο σημείων προσφέρει ομοιόμορφη κατανομή της πίεσης

IS Uppfæra í nýjstu þurrkublaðateknina.

- Sveigi blöð sem eru auðveld í uppsetningu og sem koma í stað hefðbundinna þurrkublaða
- Trygja frábær varighet og öllum veðrum og aukna endingu
- Fljótleg og auðveld í uppsetningu
- Fást einnig með beinum tengjum fyrir uppsetningu þurrkublaða af upprunalegru gerð

1. Samhverf vindskíð - Samhverf vindskíð dregur úr vindmótstöðu og gefur færi á að festa blaðið við bæði LHD- og RHD-rúðþurrkufæri
2. Einkaleyfandi fjölnota Trico-tengi - Hægt að festa örugglega á alla 9x3mm og 9x4mm þurrkuarma með krókum
3. Móttá gúmmí frá Trico - Einstakt tvískipt Trico-efni Upprunaleg mótun
4. Boglagla hnínn með einföldum fl - Byrj upp á þrepalusa þrýstingspunkta til að dreifa þrýstingnum einn jafnar yfir þurrkublaðið endilangt
5. Sérhannað Trico-tengi - Tvöfaldir þrýstingspunktar jafna dreifingu þrýstings

CZ Vylepšení na nejnovější technologii list bezramnkových stěračů.

- Retro lista stěračů pro vylepšení tradičních stěračů na nejmodernější automobilovou technologii
- Nabízí špičkový výkon za jakéhokoliv počasí a prvotřídní odolnost
- Rychlá a snadná instalace
- K dispozici rovněž s originálními spojkami pro přímé osazení

1. Symetrický spoiler - Symetrický spoiler snižuje vztlak větru a umožňuje zapojení do systému levého i pravého předního stěračě
2. Patentovaný univerzální konektor Trico - Spolehlivě použitelný do všech 9x3mm a 9x4mm závěsných ramen stěračů
3. Guma vytvořená společností Trico - Jediněčný dvousložkový materiál Trico pro originální díly
4. Konstrukce držáku na jednom nosníku - Nabízí nekonečný počet bodů dotyku pro rovnoměrné rozložení tlaku po celé délce stěračě
5. Exkluzivní spáňho Trico - Dvoubodová konstrukce umožňuje rovnoměrné rozložení tlaku

FI Päivitä viimeisimpään rungottomaan pyyhkijänsulkateknikkaan.

- Rungottomalla Retro-fit-pyyhkijänsulalla päivität perinteiset tuulilasinyyhkiät käyttämään autoalan viimeisintä teknologiaa
- Ylivoinainen kaiken sään suorituskky ja parempi kestävyys
- Nopea ja helppo asennus
- Saatavana myös suoraan asennettavilla aluperäisen kaltaisilla liittännöillä

1. Symmetrinen ilmanohjain - Symmetrinen ilmanohjain vähentää tuulen nostoa ja voidaan asentaa niin vasemman- kuin oikeanpuoleisen ohjauksen pyyhkijäjärjestelmään
2. Patentoitu Trico-yleisliitin - Varmu kinnitys kaikkein 9x3 mm:n ja 9x4 mm:n koukulla varustettuihin pyyhkijän varsiin
3. Tricon kehitelemä kumi - Ainutlaatuinen Tricon kahden materiaalin OE-muottili
4. Yhden rihtan rungoton muottili - Ääretön määrä painepisteitä takaavat paineen tasaisen jakautumisen koko pyyhkijän sulan pituudelle
5. Eriyhtinen Trico-liitin - Kahden pisteen muottili takaa tasaisen paineen jakautumisen

EE Võta kasutusele raamiga klaasipuhasti harja klaasutehnoloogia.

- Retro-fit raamiga hari tavapärase klaasipuhastite muutmiseks uusima sõidukitehnoloogia klaasipuhastiteks
- Tagab suurepärase toimimise ja suurendatud vastupidavuse kõigis ilmastikutingimustes
- Kiire ja lihtne paigaldada
- Saadaval ka otseühendusega OE tüüpi liitmikega

1. Sümmeetriline spoiler - Sümmeetriline spoiler vähendab tuuletõstet ja võimaldab ühendada nii LHD kui ka RHD klaasipuhasti süsteemid
2. Trico patenteeritud universaalne liitmik - Turvaline ühendus kõikide 9x3 mm ja 9x4 mm haakklaasipuhasti hoobadega
3. Trico spetsiaalse koostisega kummi - Unikaalne Trico kahekomponentilise materjal OE koostis
4. Uhekorde liitiraamiga konstruktsioon - Tagab asetmetta survepunktide ühtlaseks survetuoteks kogu harja pikkuse ulatuses
5. Eksklusivne Trico ühendus - Kahepunktiline konstruktsioon tagab ühtlase survetuotuse

RO Modernizare la cea mai nouă tehnologie de lamă de ștergător fără cadru.

- Adaptați lamați fără cadru pentru modernizarea ștergătoarelor convenționale la cea mai nouă tehnologie folosită la vehicule
- Oferă performanță superioară și durabilitate îmbunătățită în toate condițiile meteorologice
- Rapid și ușor de instalat
- Este disponibilă, de asemenea, și cu conexiuni de tip echipament original cu montare directă

1. Spoiler simetric - Spoilerul simetric reduce portanța și permite fixarea pe ambele sisteme de ștergătoare LHD și RHD
2. Conector universal brevetat Trico - Fixare sigură pe toate brațele de ștergător cu cârlig de 9x3 mm și 9x4 mm
3. Cauciuc formulat Trico - Formulare unică Trico, de tip echipament original, cu material dublu
4. Design fără cadru cu pană de ghidare simplă - Oferă puncte infinite de presiune pentru distribuția uniformă a presiunii pe toată lungimea lamei
5. Sistem de cuplare exclusiv Trico - Designul dublu oferă distribuția uniformă a presiunii

SI Nadgradnja na najnovjšo tehnologijo ploskih brisalcev.

- Ploska metala za naknadno nadgradnjo konvencionalnih brisalcev na najodobnejšo tehnologijo za vozila.
- Nudi izjemne zmožljivosti v vseh vremenskih pogojih in izboljšano dolgotrajnost
- Hitra in enostavna namestitve
- Prav tako na voljo za priključke tipa OE za neposredno namestitve

1. Simetrični spojler - Simetrični spojler zmanjšuje vetrni upor ter omogoča namestitve na sisteme brisalcev pri vozilih z volanom na levi in na desni strani
2. Patentiran univerzalni priključek Trico - Trdna namestitve na vse nosilce brisalcev s kajlji velikosti 9x3 mm in 9x4 mm
3. Sestavljena guma Trico - Edinstvena sestava kot originalna oprema Triko iz dvojnega materiala
4. Zasnovana enojne nosilne letve - Zagotavlja neskončno število točk pritiska na brisalce za enakomerno porazdelitev pritiska po celotni dolžini metlice
5. Ekskluzivna spojka Trico - Dvotočkovna zasnovna zagotavlja enakomerno porazdelitev pritiska

TRICO NeoForm[®]



Upgrade to the latest beam wiper blade technology.



- Retro-fit beam blade to upgrade conventional wipers to the very latest vehicle technology
- Offers superior all-weather performance & enhanced durability
- Quick & easy to install
- Also available with direct fit OE type connections
- Available in lengths from 350mm to 800mm



1 Symmetrical Spoiler
Symmetrical spoiler reduces windlift & allows fitment to both LHD & RHD wiper systems

2 Patented Trico Universal Connector
Secure fitment to all 9x3mm & 9x4mm hook wiper arms

3 Trico Formulated Rubber
Unique Trico dual material OE formulation

5 Exclusive Trico Coupler
Twin point design offers even pressure distribution

4 Single Spline Beam Design
Offers infinite pressure points for even pressure distribution across the whole blade length

DE Das Basic-Standardwischerblatt

- Optimiertes Sortiment mit nur 15 Lagerposten für Standardhakenwischerarme
- Schnelle & einfache Montage
- Ausgezeichnete Wischleistung
- In allen gängigen Längen von 280 mm bis 700 mm erhältlich

1. Aerodynamisches Design - Entlüftete Struktur für eine höhere Windabweisung auch bei hohen Geschwindigkeiten
2. Vormontierter Quick-Fit-Verbinder - Schnelles und einfaches Aufstecken auf alle gängigen Haken-Wischerarme mit den Abmessungen 9 x 3 mm und 9 x 4 mm
3. Vollmetallkonstruktion - Konstruktion aus verzinktem Stahl für optimale Widerstandsfähigkeit und Wischleistung
4. Gummi nach Trico-Rezeptur - Graphitbeschichteter Gummi für einen geschmeidigeren Wischvorgang und eine längere Produktlebensdauer

FR Le balais traditionnel efficace et intelligent

- Gamme optimisée de 15 modèles pour les bras d'essuie-glace traditionnels à crochet
- Installation simple et rapide
- Excellente performance de balayage
- Disponible dans toutes les longueurs requises, entre 280 mm et 700 mm

1. Conception aérodynamique - La structure ventilée permet de réduire le soulèvement du balai sous l'action du vent à grande vitesse
2. Connecteur rapide pré-monté - Montage simple et rapide de tous les bras d'essuie-glace à crochets courants 9x3 mm et 9x4 mm
3. Toute la construction est métallique - Structure en acier galvanisé pour une durabilité et une performance optimales
4. Caoutchouc de formulation Trico - Revêtement graphité pour un balayage plus régulier et une durée de vie prolongée

ES La verdadera escobilla convencional

- Gama optimizada de solo 15 SKU para brazos limpiaparabrisas convencionales con gancho tradicional
- De instalación fácil y rápida
- Rendimiento de barrido excelente
- Disponible en todas las longitudes: desde 280 hasta 700 mm

1. Diseño aerodinámico - La estructura ventilada reduce la elevación por el efecto del viento a alta velocidad.
2. Conector de instalación rápida preinstalado - Instalación directa, rápida y fácil en todos los brazos limpiaparabrisas con gancho comunes de 9x3mm y 9x4mm.
3. Estructuras de metal - Estructura de acero galvanizado para proporcionar una durabilidad y un rendimiento óptimos.
4. Goma formulada de Trico - Goma recubierta con grafito para proporcionar un barrido más suave y una vida útil prolongada

IT La spazzola tradizionale per eccellenza.

- Gamma ottimizzata di soli 15 articoli da tenere a magazzino per le spazzole tradizionali con braccio a gancio
- Installazione rapida e semplice
- Pulizia dalle prestazioni eccellenti
- Disponibile in tutte le lunghezze necessarie 280 mm - 700 mm

1. Design aerodinamico - La struttura ventilata riduce il carico del vento a velocità elevate
2. Connettore a montaggio rapido premontato - Montaggio diretto semplice e rapido in tutti i bracci di tergicristalli a gancio da 9x3mm e 9x4mm
3. Struttura interamente in metallo - Struttura in acciaio zincato per durata e prestazioni ottimali
4. Gomma dalla formulazione Trico esclusiva - Gomma rivestita di grafite per una pulizia più fluida e una durata più elevata

PT Escova convencional prática

- Gama otimizada de apenas 15 SKUs para escovas limpa-vidros com braço em gancho tradicionais
- Colocação simples e rápida
- Excelente desempenho de limpeza
- Disponível em todos os comprimentos necessários - 280 mm a 700 mm

1. Design aerodinâmico - A estrutura ventilada reduz a elevação pelo vento a alta velocidade
2. Conector integrado de encaixe rápido - Encaixe direto rápido e fácil em todos os braços comuns de escovas limpa-vidros com gancho de 9x3 mm e 9x4 mm
3. Estrutura totalmente de metal - Estrutura de aço galvanizado para uma durabilidade e desempenho excelentes
4. Borracha formulada Trico - Borracha com revestimento de grafite para uma limpeza mais suave e uma vida útil prolongada

NL Het no-nonsense conventionele blad

- Geoptimaliseerd assortiment van slechts 15 SKUs voor traditionele wissersarmen met conventionele haak
- Snelle en gemakkelijke installatie
- Uitstekende wissersprestaties
- Verkrijgbaar in alle vereiste lengtes, 280 mm - 700 mm

1. Aerodynamisch ontwerp - Geventileerde structuur reduceert optillen door de wind op hoge snelheid
2. Vooraf gemonteerde Quick Fit-connector - Snelle en gemakkelijke directe pasvorm op alle veelvoorkomende haakwissersarmen van 9x3mm & 9x4mm
3. Volledig metaal constructie - Gegalvaniseerde stalen structuur voor optimale duurzaamheid en prestaties
4. Trico geformuleerd rubber - Rubber met grafietcoating voor soepel wissen en een langere levensduur

NO Vanlige blader uten noe tull

- Optimalisert utvalg av bare 15 SKU-er for tradisjonelle, vanlige vindusviskeramer med hektefunksjon
- Rask og enkel installering
- Glimrende vindusviskeegenskaper
- Tilgjengelig i alle påkrevde lengder, fra 280-700 mm

1. Aerodynamisk utforming - Ventilert struktur reduserer vindbelastningen ved høye hastigheter
2. Forhåndsmontert rask tilkobling - Rask og enkel direkte montering på alle vanlige 9x3 og 9x4 mm viskeramer med krokfester
3. Helmetallkonstruksjon - Galvanisert stålstruktur gir optimal varighet og ytelse
4. Gummi av Trico-formel - Grafittbelegg som gir smidigere vindusvisking og lengre levetid

DK Det konventionelle blad uden dikkedar

- Optimeret udvalg med blot 15 vareenheder til traditionelle, konventionelle viskerame med krog
- Hurtig og let montering
- Fremragende viskerestation
- Fås i alle nødvendige længder 280 mm - 700 mm

1. Aerodynamisk design - Den ventilerede struktur giver mindre vindloft ved højere hastighed
2. Forhåndsmonteret beslag til hurtig montering - Hurtig og let direkte montering på alle almindelige 9x3 mm og 9x4 mm viskerame med krog
3. 100 % metallkonstruktion - Galvaniseret stålstruktur giver optimal holdbarhed og de bedste resultater
4. Trico-udformet gummi - Grafittbelagt gummi giver en bedre vinduesviskning og længere holdbarhed

SE Det gamla hederliga konventionella torkarbladet

- Optimalt utbud med endast 15 lagerplatsenheter för vanliga traditionella torkaramar med krok
- Snabb och enkel montering
- Utmärkt torkprestanda
- Finns i alla längder: 280 mm - 700 mm

1. Aerodynamisk design - Lufthålsstruktur minskar vindlyft vid höga hastigheter
2. Förhåndsanpassad snabbmonteringsanslutare - Snabb och enkel direktmontering till alla vanliga krok på 9x3 mm och 9x4 mm krok på 9x3 mm och 9x4 mm
3. Konstruktion helt i metall - Galvaniserad stålstruktur för optimal hållbarhet och prestanda
4. Trico-utformat gummi - Gummi med grafittbeläggning för jämnare torkning och utökad livslängd

PL Pióro wycieraczki klasycznej w nowej odsłonie

- Zoptymalizowany asortyment zaledwie 15 SKU dla klasycznych ramion wycieraczek z uchwytem hakowym
- Szybki i prosty montaż
- Doskonale wycieranie
- Dostępne we wszystkich wymaganych długościach od 280 mm do 700 mm

1. Aerodynamiczny kształt - Otwory w konstrukcji redukują efekt unoszenia się wycieraczki przy dużych prędkościach
2. Zamocowana wstępnie szybkozłączka - Szybkie i proste mocowanie do wszystkich popularnych wycieraczek z uchwytem hakowym 9mm x 3mm i 9mm x 4mm
3. Galwanizowana metalowa konstrukcja - Konstrukcja ze stali galwanizowanej zapewnia optymalną wytrzymałość i skuteczność wycierania
4. Formowanie gumy w technologii Trico - Grafitowa powłoka zwiększa płynność wycierania i przedłuża żywotność wycieraczki

RU Классическая щетка без излишеств

- Оптимизированный ассортимент всего из 15 номенклатурных позиций для классических стеклоочистителей с креплением рычага типа "крючок"
- Быстрая, простая установка
- Превосходное качество очистки стекла
- Доступна во всех необходимых диапазонах длины от 280мм до 700мм

1. Аэродинамическая конструкция - Вентилируемая структура уменьшает подъемную силу ветра на высоких скоростях
2. Предварительно установленное быстросъемное соединение быстрая и простая непосредственная установка на все обычные стеклоочистители с креплением типа "крючок" размером 9x3 мм и 9x4 мм
3. Цельнометаллическая конструкция - Оцинкованная стальная конструкция обеспечивает оптимальную прочность и эффективность
4. Состав каучука от компании Trico - Каучук с графитовым покрытием для более равномерной очистки стекла и длительного срока службы

GR Υβριδικά μάκτρα τυπικού εξοπλισμού

- Στυλιζαρισμένο υβριδικό μάκτρο, όπως αυτό που τοποθετείται στα περισσότερα σύγχρονα αυτοκίνητα και κορεάτικα οχήματα
- Η υποδομή μονοκόμματου στυλ χρησιμοποιεί εξελιγμένη τεχνολογία καθαρισμού, για βελτιωμένη κατανομή της πίεσης
- Το στυλιζαρισμένο πλαστικό σπόιλερ προστατεύει το μάκτρο και βελτιώνει την απόδοση
- Κατασκευάζονται στις εγκαταστάσεις κατασκευής προϊόντων για κατασκευαστές πρωτότυπου εξοπλισμού, σύμφωνα με τις προδιαγραφές των κατασκευαστών
- Μπορεί να χρησιμοποιηθεί επίσης ως εναλλακτική αναβάθμισης για τους συμβατικούς υαλοκαθαριστήρες

1. Αεροδυναμική σχεδίαση Η ειρσοζόμενη δομή μειώνει την ανύψωση από τον αέρα στις υψηλές ταχύτητες
2. Προτοποθετημένο σύνδεσμο γρήγορης τοποθέτησης Γρήγορη και εύκολη άμεση τοποθέτηση σε όλους τους συνήθεις αγκιστρικούς βραχίονες υαλοκαθαριστήρων 9x3 mm και 9x4 mm
3. Κατασκευή εξ ολοκλήρου από μέταλλο Δομή από γαλβανισμένο χάλυβα για βελτιωτή αντοχή και απόδοση
4. Καουτσούκ μορφοποιημένο από την Trico Καουτσούκ με επίστρωση από γραφίτη για ομαλότερη λειτουργία και παρατεταμένη διάρκεια ζωής

IS Einfalt, hagnytt, hefðbundni þurrkuablað

- Aðeins þarf að eiga 15 gerðir á lager fyrir hefðbundna þurrkuablaðanna með krókum
- Fljótleg og auðveld í uppsetningu
- Frábær afköst við rúðuhreinsun
- Fást í öllum áskildum lengdum, 280–700 mm

1. Straumlinuðug hönnun - Uppbygging með góðu loffflæði dregur úr vindmótstöðu á miklum hraða
2. Foruppsett tengi fyrir fljótlega skiptingu - Fljótlegt og auðvelt að tengja milliðalaust við alla algenga 9x3 mm og 9x4 mm þurrkuarma með krókum þurrkuarma með krókum
3. Allir hlutar úr málm - Úr galvaniseruðu stáli til að hámarka endingu og frammistöðu
4. Mótáð gummi frá Trico - Grafittúðað gummi gerir hreinsunina myrki og lengir notkunartímann

CZ Praktické tradiční lišty

- Optimalizovaná skupina pouze 15 skladových jednotek pro klasické tradiční hákové ramínkové stěrače
- Rychlá a snadná instalace
- Vynikající účinnost stírání
- K dispozici ve všech požadovaných délkách 280–700 mm

1. Aerodynamický tvar - Systém odvětrávání snižuje vztlak větru při vysoké rychlosti
2. Předudčený konektor pro rychlé zapojení - Rychlé a snadné okamžité uchytení do všech běžných 9x3mm a 9x4mm závěsných ramen stěračů
3. Celokovová konstrukce - Konstrukce z galvanizované oceli zajišťuje optimální odolnost a vykonnost
4. Guma vytvořená společností Trico - Guma potažená grafitem zajišťuje hladší stěra a prodlužuje životnost výrobku

FI Mutkaton perinteinen pyyhkijänsulka

- Optimoitu vain 15 tuotekoodin valikoima perinteisiä koukkukinnityksellä varustettuja pyyhkijänsulka varten
- Nopea ja helppo asennus
- Erinomainen pyyhkimisjälki
- Saatavana kaikilla tarvittavilla pituuksilla 280 mm – 700 mm

1. Aerodynaaminen muotoilu - Ilmäreiälli varustettu rakenne vähentää tuulen nostetta suurissa ajonopeuksissa
2. Ennalta sovitettu pika-asennettava liitin - Nopea ja helppo suora asennus kaikkiin yleisiin 9 x 3 mm:n ja 9 x 4 mm:n koukkulla varustettuihin pyyhkijän varsiin
3. Valmistettu kokonaan metallista - Galvanoitu teräsrakenne takaa optimaalisen kestävyuden ja suorituskyvyn
4. Tricon kehittelemä kumi - Grafitipinnoitettu kumi takaa tasaisemman pyyhkimisen ja pidemmän käyttöäin

EE Lihtsata paigaldatav tavapärane hari

- Kõigest 15 laotõhku suurone optimaalne valik traditsioonilisele tavapärastele haaklaasipuhasti hoobadele
- Kiire ja lihtne paigaldada
- Klaasipuhasti suurepärase tõhusus
- Kätesaadav kõigis vajalikes mõõdutes vahemikus 280–700 mm

1. Aerodünaamiline konstruktsioon - Ventileeritud struktuur vähendab tuuletõistet suuritel kiirustel
2. Eelseadistatud Quick-Fit liitmik - Kiire ja lihtne ühendamine kõike tavapärase 9 x 3 mm ja 9 x 4 mm haaklaasipuhasti hoobadega
3. Täismetallist konstruktsioon - Tsingitud terasest struktuur optimaalseks vastupidavuseks ja tõhususeks
4. Trico spetsiaalselt koostisega kummi - Grafittkattega kummi sujuvamaks klaasipuhastuseks ja eluea pikendamiseks

RO Lama conventională eficientă

- Gamă optimizată de doar 15 SKU-uri pentru brațe tradiționale de ștergători de tip cârlig convenționale
- Instalare rapidă și ușoară
- Performanță excelentă de ștergere
- Disponibilă în toate lungimile necesare 280 mm - 700 mm

1. Design aerodinamic Structura ventilată reduce portanța la viteze mari.
2. Conector cu montare rapidă încorporat Fixare directă, rapidă și ușoară pe toate brațele obișnuite de ștergător cu cârlig de 9x3 mm și 9x4 mm
3. Construcție completă din metal Structură din oțel galvanizat pentru durabilitate și performanță optime
4. Cauciuc formulat Trico Cauciuc cu strat de acoperire din grafit pentru o curățare mai fină și o durată de viață prelungită

SI Konvencionalna metlica brez nesmiselnosti

- Optimizirana paleta s samo 15 inventarnimi številkami za tradicionalne kljukaste ročice za brisanje
- Hitra in enostavna namestitev
- Učinkovito brisanje
- Na voljo v vseh dolžinah od 280 mm do 700 mm

1. Aerodinamična zasnova Zračna struktura zmanjšuje vetni upor pri visokih hitrostih
2. Predhodno nameščen priključek za hitro namestitev Hitra in enostavna neposredna namestitev na vse običajne nosilce brisalcev s kavlji velikosti 9x3 mm in 9x4 mm
3. Samo kovinska struktura Pocinkana jeklena konstrukcija za optimalno trpežnost in učinkovitost
4. Sestavljena guma Trico Guma z grafitno prevleko za bolj gladko brisanje in daljšo življenjsko dobo



The no-nonsense conventional blade.

- Optimised range of just 15 SKU's for traditional conventional hook wiper arms
- Quick & easy installation
- Excellent wipe performance
- Available in all required lengths 280mm - 700mm

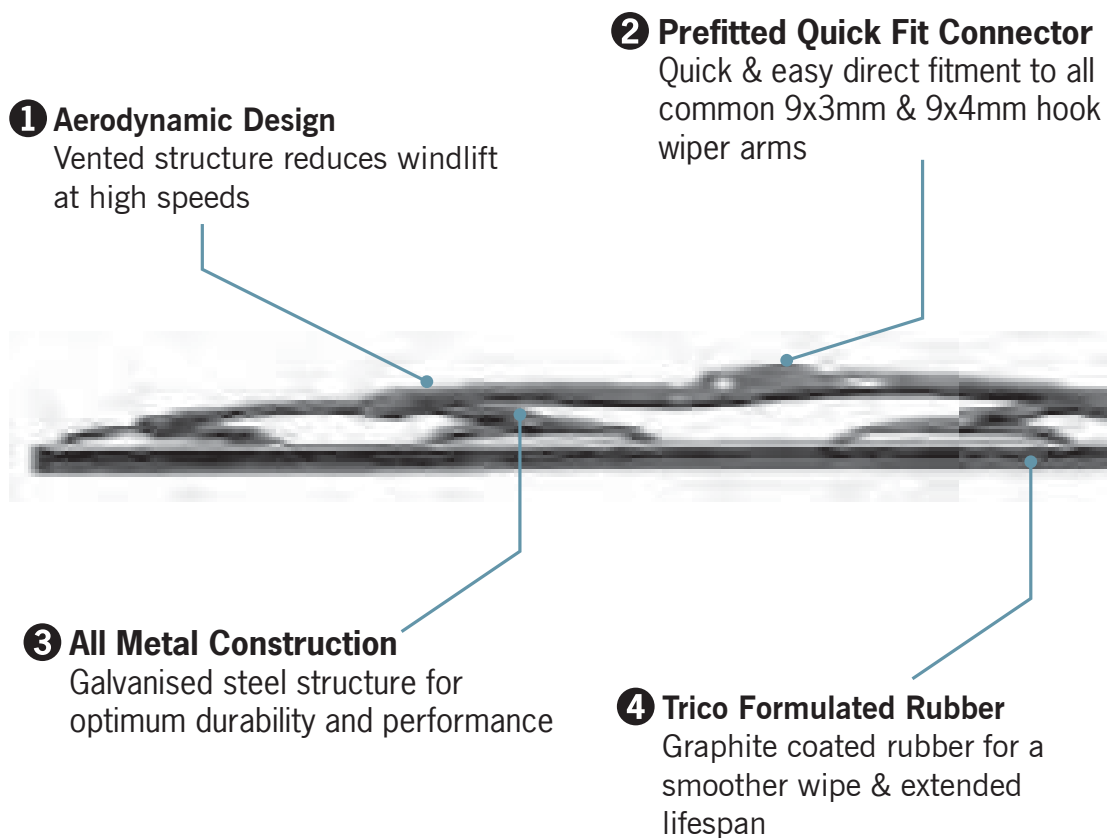

DE Mehr großartige Produkte von Trico.

Trico ICE - Das erste Beam-Wischerblatt speziell für den Winter.
Speziell dafür entwickelt, um auch unter den härtesten Bedingungen im Winter optimale Leistung zu erzielen. In Längen zwischen 400 mm bis 700 mm erhältlich

Trico TX - Wischerblätter für den gewerblichen Gebrauch an schweren Nutzfahrzeugen.
Leistungsfähige Wischerblätter für den gewerblichen Gebrauch in Standard- und Beam-Ausführung für alle leichten Gewerbfahrzeuge und schweren Nutzfahrzeuge. In Längen zwischen 400 mm bis 1000 mm erhältlich

Trico SPRAY - Scheibenwischerpumpen.
Umfassendes Angebot an Scheibenwischerpumpen für die Windschutzscheibe, in Standardausführung und direkt für die Originalteile der Fit-Designs; Lieferumfang umfasst außerdem Scheibenwischeranlagen-Ersatzteile und -Zubehör.
TRICO - Wischermotoren.
Von Trico als Erstausrüstung geliefert und jetzt auch für den Aftermarkt verfügbar.

FR D'autres excellents produits sont proposés par Trico.

Trico ICE - Le premier balai à profil aérodynamique spécial hiver
Adapté spécialement aux conditions hivernales les plus rigoureuses telles qu'en temps de neige et de glace. Disponible en plusieurs longueurs, entre 400 mm et 700 mm

Trico TX - Balais industriels à usage intensif.
Balais industriels à usage intensif, de type traditionnel et à profil aérodynamique, pour tous les véhicules utilitaires légers et les poids lourds. Disponible en plusieurs longueurs, entre 400 mm et 1000 mm

Trico SPRAY - Pompes de lave-glace pour pare-brise.
Une gamme complète de pompes de lave-glace pour pare-brise universelles et d'origine à montage direct, complétée par des accessoires et des pièces détachées pour système de lave-glace.

TRICO - Moteurs d'essuie-glace.
Fournis en tant que pièces d'origine par Trico et désormais disponibles sur le marché des pièces de rechange.

ES Otros productos excelentes de Trico

O bien, consulte más información en línea en www.trico.eu.com.
Trico ICE - La primera escobilla flexible diseñada para el invierno.
Adaptada especialmente para funcionar incluso en las condiciones invernales con nieve y hielo más rigurosas. Disponible en longitudes desde 400 hasta 700 mm

Trico TX - Escobillas comerciales reforzadas.
Escobillas comerciales reforzadas para limpiaparabrisas de estilo convencional y estilo flexible para todo tipo de vehículos comerciales ligeros y pesados. Disponible en longitudes desde 400 hasta 1000 mm

Trico SPRAY - Bombas limpiaparabrisas.
Gama completa de bombas limpiaparabrisas en diseño universal y diseño de instalación directa de EO que incluye repuestos y accesorios del sistema de lavado.

TRICO - Motor del limpiaparabrisas.
Trico lo comercializa como equipo original y ya está a la venta en el mercado de accesorios.

IT Trico vi offre tantissimi altri prodotti.

Trico ICE - Il primo tergicristalli a spazzola piatta specialistico per l'inverno.
Specificamente adattato per assicurare prestazioni ottimali anche nelle condizioni invernali di neve e ghiaccio più estreme. Disponibile nelle lunghezze da 400 mm a 700 mm

Trico TX - Spazzole commerciali ad alta resistenza.
Spazzole tergicristalli commerciali ad alta resistenza sia tradizionali che a spazzola piatta, adatte a tutti i veicoli commerciali leggeri e pesanti. Disponibile nelle lunghezze da 400 mm a 1000 mm

Trico SPRAY - Pompe del lavacrystallo del parabrezza.
Gama completa di pompe del lavacrystallo del parabrezza sia di tipo universale che di tipo OE con montaggio diretto, integrate con ricambi e accessori per il lavacrystallo.

TRICO - Motori per tergicristalli.
Forniti da Trico come equipaggiamento originale e disponibile ora per il mercato post-vendita.

PT Mais produtos excelentes oferecidos pela Trico.

Trico ICE - A primeira escova limpa-vidros plana especializada para o inverno.
Especialmente adaptada para ter um excelente desempenho em invernos rigorosos, com neve e gelo. Disponível em comprimentos de 400 mm a 700 mm

Trico TX - Escovas comerciais muito resistentes.
Escovas limpa-vidros comerciais muito resistentes nos estilos convencional e plano, para todos os veículos comerciais leves e pesados. Disponível em comprimentos de 400 mm a 1000 mm

Trico SPRAY - Bombas do limpa-para-brisas.
Uma gama completa de bombas do limpa-para-brisas em designs originais de encaixe universal e direto, complementada por acessórios e peças sobresselentes do sistema de lavagem.

TRICO - Motores das escovas.
Fornecidos como equipamento original pela Trico e agora disponíveis para o mercado pós-venda.

NL Meer geweldige producten verkrijgbaar bij Trico.

Trico ICE - Het eerste gespecialiseerde winterdraagblad.
Speciaal aangepast voor hoge prestaties onder zelfs de meest zware wintersneeuw- en ijssomstandigheden. Verkrijgbaar in lengtes van 400 mm tot 700 mm

Trico TX - Commerciële bladen voor zwaar gebruik.
Commerciële wisserbladen voor zwaar gebruik in conventionele en draagbladstijlen voor alle licht-commerciële en industriële voertuigen. Verkrijgbaar in lengtes van 400 mm tot 1000 mm

Trico SPRAY - Ruitsproeierpompen.
Een volledig assortiment ruitsproeierpompen in universele en rechte streeks aan te brengen OE-ontwerpen, aangevuld door reserveonderdelen en accessoires voor het sproeisysteem.

TRICO - Ruitenwissermotoren.
Geleverd als Original Equipment door Trico en nu verkrijgbaar op de aftermarket.

NO Flere flotte produkter tilgjengelig fra Trico.

Trico ICE - Det første bombladet spesielt utformet for vinterbruk.
Spesielt tilpasset for ytelse under til og med de tøffeste vinterforhold med snø og is. Tilgjengelig i lengder fra 400-700 mm

Trico TX - Kraftige, kommersielle blader
Kraftige, kommersielle vindusviskerblader av vanlig type og med bom, for alle lette kommersielle og tunge kjøretøyer. Tilgjengelig i lengder fra 400-1000 mm

Trico SPRAY - Pumper til vindusviskere.
Et komplett utvalg av pumper til vindusviskere i universell design og OE-type med direktekobling, utfylles med reservedeler og tilbehør til vindusviskersystemet.

TRICO - Vindusviskermotorer.
Leveres som originalt utstyr av Trico, og er nå tilgjengelige for ettermarkedet.

DK Flere fantastiske produkter fra Trico.

Trico ICE - Det første flatblade specielt til vinterbrug.
Særligt tilpasset til at præstere under vinterens hårdeste sne- og isforhold. Fås i længder fra 400 mm til 700 mm

Trico TX - Ekstra kraftige blade til erhvervs køretøjer.
Ekstra kraftige erhvervsviskerblade i konventionel stil eller som flatblade til alle lette erhvervs køretøjer og tunge køretøjer. Fås i længder fra 400 mm til 1000 mm

Trico SPRAY - Sprinklervæskpumper.
Et komplet udvalg af sprinklervæskpumper i universal og direkte originaludstyr monteringsdesign kompletteret af reservedele og tilbehør til sprinklervæskesystem.

TRICO - Viskermotorer.
Leveres som originaludstyr af Trico og kan nu også fås på markedet for brugte reservedele.

SE Trico erbjuder fler förstklassiga produkter.

Trico ICE - Det första bygelösa torkarbladet specialanpassat för vintern.
Speciellt utformat för att fungera i till och med det hårdaste vintervädret med snö och is. Finns i längderna 400 mm till 700 mm

Trico TX - Torkarblad för nyttofordon och tunga fordon.
Konventionella och bygelösa torkarblad för alla lätta nyttofordon och tunga fordon. Finns i längderna 400 mm till 1000 mm

Trico SPRAY - Spolarväskpumpar.
Ett komplett utbud av spolarväskpumpar i design för universalpassning och direktpassande originaldelar, kompletterat med reservdelar och tillbehör till spolarsystemet.

TRICO - Torkarmotorer.
Levereras som originalutrustning av Trico och finns nu tillgängliga för eftermarknaden.

PL Inne doskonałe produkty marki Trico

Trico ICE - Pierwsze pióro płaskie zaprojektowane na warunki zimowe
Stworzone do niezawodnego usuwania z szyby śniegu i lodu w najtrudniejszych warunkach zimowych. Dostępne we wszystkich długościach od 400 mm do 700 mm.

Trico TX - Pióra wycieraczek pojazdów dostawczych i ciężarowych
Wytrzymałe klasyczne i płaskie pióra wycieraczek do wszystkich pojazdów dostawczych i ciężarowych. Dostępne we wszystkich długościach od 400 mm do 1000 mm.

Trico SPRAY - Pompki spryskiwaczy szyby przedniej
Kompletna oferta spryskiwaczy szyby przedniej z uniwersalnym lub bezpośrednim oryginalnym mocowaniem producenta oraz części zapasowe i akcesoria układu spryskiwaczy.

TRICO - Silniczki spryskiwaczy.
Sprzedawane przez Trico jako sprzęt oryginalny, a teraz dostępne jako zamienniki.

RU Еще больше качественной продукции от компании Trico.

Trico ICE - Первая специализированная бескаркасная зимняя щетка.
Разработана специально для работы в условиях суровой зимы с выпадением снега и образованием наледи. Доступна в диапазонах длины от 400мм до 700мм

Trico TX - Щетки с повышенной эксплуатационной надежностью для коммерческих транспортных средств.
Щетки стеклоочистителей с повышенной эксплуатационной надежностью для коммерческих транспортных средств в классическом и бескаркасном исполнении для всех малотоннажных и крупнотоннажных грузовых автомобилей. Доступны в диапазонах длины от 400мм до 1000мм

Trico SPRAY - Насосы стеклоомывателя.
Полный ассортимент насосов стеклоомывателя в универсальном и предназначенном исполнении с запчастями и комплектующими.

TRICO - Электродвигатели стеклоочистителей.
Поставляются компанией Trico как оригинальное оборудование. Теперь доступны на рынке запчастей.

GR Περισσότερα εξαιρετικά προϊόντα διατίθενται από την Trico.

Trico ICE - Ο πρώτος μονοκόμματος αλοκαθαριστήρας ειδικά για το χειμώνα.
Ειδικά προσαρμοσμένος για υψηλή απόδοση, ακόμα και στις πιο σκληρές χειμερινές συνθήκες με χιόνι και πάγο. Διατίθεται σε μήκη από 400 mm έως 700 mm

Trico TX - Μάκτρα επαγγελματικού τύπου, βαριάς χρήσης.
Μάκτρα αλοκαθαριστήρων επαγγελματικού τύπου, βαριάς χρήσης σε συμβατικό και μονοκόμματο στυλ, για όλα τα επαγγελματικά οχήματα ελαφράς και βαριάς χρήσης. Διατίθενται σε μήκη από 400 mm έως 1000 mm

Trico SPRAY - Αντλίες πλύσης παρμπρίζ.
Μια πλήρης σειρά αντλίων πλύσης αλοκαθαριστήρων σε σχεδιασμό γενικής και άμεσης τοποθέτησης τυπικού εξοπλισμού, η οποία συμπληρώνεται από ανταλλακτικά και εξαρτήματα του συστήματος πλύσης.

TRICO - Μοτέρ αλοκαθαριστήρων.
Διατίθενται ως μέρος του τυπικού εξοπλισμού από την Trico και πλέον διατίθενται και στην αγορά εξαρτημάτων μετά την πώληση.

IS Fleiri frábærar vörur frá Trico

Trico ICE - Fyrsta sérhannaða þurrkublaðið fyrir vetrarakstur.
Sérhannað til að virkja vel við jafnvæl erfiðustu vetraraðstæður, snjókomu og ísingu. Fást í lengdum frá 400–700 mm

Trico TX - Þurrkublaðið fyrir mikið álag til notkunar í atvinnuskyni
Þurrkublaðið af bæði hefðbundinni og sveigðri gerð, til notkunar í atvinnuskyni fyrir léttri bifreiðar og þungavinnubifreiðar. Fást í lengdum frá 400–1000 mm

Trico SPRAY - Skolunardælur fyrir framrúður.
Flýguin lína skolunardæla fyrir framrúður, með ahlíða og beinum tengjum fyrir upprunalegan búnað, ásamt aukaskolunardælum og fylgihlutum.

TRICO - Þurrkumótórar.
Fylgja sem upprunalegur búnaður frá Trico og eru nú einnig fáanlegir fyrir eftirslu.

CZ Nabídka dalších skvělých výrobků Trico.

Trico ICE - První lista stěrače určená speciálně pro zimní období.
Speciálně upravena, aby dokonale fungovala i v nejnáročnějších zimních podmínkách plných sněhu a ledu. K dispozici v délkách 400–700 mm

Trico TX - Komerční listý pro velké vytížení.
Komerční listý stěračů pro velké vytížení v tradičním i bezramínkovém provedení, pro všechna lehká komerční vozidla i vozidla s velkým vytížením. K dispozici v délkách 400–1000 mm

Trico SPRAY - Čerpadla omývače předního skla.
Kompletní portfolio čerpadel omývačů předního skla v univerzálních i originálních provedeních, doplněné o náhradní díly a příslušenství pro systém omývače.

TRICO - Motory omývače.
Dodáváno jako originální vybavení společnosti Trico a nyní k dispozici pro sekundární trh.

FI Tricolta saatavilla lisää upeita tuotteita.

Trico ICE - Ensimmäinen erityinen rungoton talvipyhkiänsulka.
Erityisesti mukautettu toimimaan talven rankimmissakin lumi- ja jääolosuhteissa. Saatavana pituuksilla 400 mm – 700 mm

Trico TX - Lujatekoiset pyyhkiänsulat ammattikäyttöön.
Lujatekoiset ammattikäyttöön tarkoitett tuulliasin pyyhkiänsulat niin perinteisinä kuin rungottomina mallina kaikkein kevyisin ja raskaisin hyötäjoukoseihin. Saatavana pituuksilla 400 mm – 1 000 mm

Trico SPRAY - Tuulliasin pesimen pumput.
Kattava tuulliasin pesimen pumppujen valikoima sisältää niin yleisiä kuin suoraan asennettavia alkuperäisönsä sopivia malleja sekä lisäksi tuulliasin pesujärjestelmän varaosia ja lisävarusteita.

TRICO - Pyyhkimen moottorit.
Tarjotaan Trico alkuperäisvarusteluna, mutta nyt saatavana myös jälkimerkkinä.

EE Rohkem suurepärsid Trico tooteid

Trico ICE - Esimene spetsiaalne raamiga talvehari
Spetsiaalselt kohandatud toimimaks ka kõige karmimates lume- ja jäätingimustes. Saadaval pikkused vahemikus 400–700 mm

Trico TX - Süüdiukite harjad raskeveokitetele
Raskeveokite klaasipuhasti harjad tavapärasele ja raamiga klaasipuhastite, kõikidele tarbesüdiukitele ja raskeveokitetele Saadaval pikkused vahemikus 400–1000 mm

Trico SPRAY - Klaasipuhastusvedeliku pumbad
Lai valik klaasipuhastusvedeliku universaalse ja otsuühendusega OE konstruktsiooniga pumpasid, millele on lisatud pesurisüsteemi varuosad ja tarvikud.

TRICO - Klaasipuhasti mootorid
Tarnitakse Trico originaalsete seadmetena ning on nüüd kättesaadaval järelturul

RO Mai multe produse excelente disponibile din partea companiei Trico.

Trico ICE - Prima lamă specială de iarnă fără cadru.
Special adaptată pentru a face față chiar și celor mai grele condiții de iarnă și gheață. Disponibilă în lungimi de la 400 mm la 700 mm

Trico TX - Lame pentru vehicule comerciale grele.
Lame de ștergător pentru vehicule comerciale grele în stil convențional și fără cadru, pentru toate vehiculele comerciale ușoare și grele. Disponibilă în lungimi de la 400 mm la 1000 mm

Trico SPRAY - Pompe de spălător parbriz.
O gamă completă de pompe de spălător parbriz de tip echipament original cu montare universală și directă, completată cu piese de schimb și accesorii pentru sistemul de spălare.

TRICO - Motoare de ștergător.
Furnizate ca echipamente originale de către Trico și disponibile în prezent pe piața de accesorii.

SI Na voljo je še več odličnih izdelkov Trico.

Trico ICE - Prva namenska ploska metlica za zimo.
Posebej izdelana za delovanje v najtežjih zimskih pogojih. Na voljo od 400 mm do 700 mm dolžine

Trico TX - Trpežne komercialne metlice.
Konvencionalni in ploski trpežni komercialni brisalci za vsa lahka in težka gospodarska vozila. Na voljo od 400 mm do 1000mm dolžine

Trico SPRAY - Črpalke za brisanje vetrobranskega stekla.
Celovita paleta črpalke za brisanje vetrobranskega stekla, za univerzalno ali neposredno OE pitrditev, dopolnjena z nadomestnimi deli in dodatno opremo za sistem za brisanje.

TRICO - Motorji brisalcev.
Dobavljeno kot originalna oprema Trico in zdaj na voljo za poprodajo.

More great products available from Trico.

Catalogued separately, contact your sales representative or the Trico Europe sales office for more information about these ranges.

Or, find more details online at www.trico.eu.com

TRICOIce®

Premium winter weather blade.

Specially adapted beam blade that performs in even the harshest winter snow & Ice conditions.

Available in lengths from 400mm to 700mm



TRICO TX

Heavy Duty Commercial Blades

Heavy duty commercial wiper blades in conventional and beam styles, for all light commercial & heavy duty vehicles.

Available in lengths from 400mm to 1000mm



TRICO Spray

Windscreen washer pumps

A complete range of windscreen washer pumps in universal & direct OE fit designs, complemented by washer system spares & accessories.



TRICO

Wiper motors

Supplied as Original Equipment by Trico and now available to the aftermarket.





ACURA

CL		96	03	EF600	EF500		TF600L	A/D	TF500L	FX600	BC+E	FX500	NF600	NF500	T600	T500	
INTEGRA		85	90	EF450	EF450		TF450L	A/D	TF450L	FX450	A/D	FX450	NF450	NF450	T450	T450	
		90	01	EF450	EF450		TF450L	A/D	TF450L	FX450	A/D	FX450	NF450	NF450	T450	T450	
		85	90	EF450	EF450	EF450	TF450L	A/D	TF450L	FX450	A/D	FX450	NF450	NF450	T450	T450	T450
		90	93	EF450	EF450	EF450	TF450L	A/D	TF450L	FX450	A/D	FX450	NF450	NF450	T450	T450	T450
		85	90	EF450	EF450		TF450L	A/D	TF450L	FX450	A/D	FX450	NF450	NF450	T450	T450	
		93	01	EF450	EF450		TF450L	A/D	TF450L	FX450	A/D	FX450	NF450	NF450	T450	T450	
LEGEND		86	96	EF500	EF500		TF500L	A/D	TF500L	FX500	A/D	FX500	NF500	NF500	T500	T500	
		96		EF550	EF550		TF550L	A/D	TF550L	FX550	A/D	FX550	NF550	NF550	T550	T550	
		87	96	EF500	EF500		TF500L	A/D	TF500L	FX500	A/D	FX500	NF500	NF500	T500	T500	
MDX		00	05	EF600	EF530		TF600L	A/D	TF530L	FX600	A/D	FX530	NF600	NF530	T600	T530	
NSX		90		EF550	EF550		TF550L	A/D	TF550L	FX550	A/D	FX550	NF550	NF550	T550	T550	
		95	97	EF550	EF550		TF550L	A/D	TF550L	FX550	A/D	FX550	NF550	NF550	T550	T550	
RDX		06		EF650	EF400		TF650L	A/D	TF400L	FX650	A/D	FX400	NF650	NF400	T650	T400	
RL		95	04	EF550	EF480		TF550L	A/D	TF480L	FX550	A/D	FX480	NF550	NF480	T550	T480	
RSX		01		EF600	EF500		TF600L	A/D	TF500L	FX600	A/D	FX500	NF600	NF500	T600	T500	
SLX		95	99	EF500	EF500	EF350	TF500L	A/D	TF500L	FX500	A/D	FX500	NF500	NF500	T500	T500	T350
TL		95	03	EF600	EF480		TF600L	A/D	TF480L	FX600	A/D	FX480	NF600	NF480	T600	T480	
		03	08	EF650	EF480		TF650L	A/D	TF480L	FX650	A/D	FX480	NF650	NF480	T650	T480	
TSX		03	08	EF650	EF400		TF650L	A/D	TF400L	FX650	A/D	FX400	NF650	NF400	T650	T400	
VIGOR		91	94	EF600	EF480		TF600L	A/D	TF480L	FX600	A/D	FX480	NF600	NF480	T600	T480	

AIXAM

400		00		EF580			TF550L	A/D		FX550	A/D		NF550		T580		
500		97		EF580			TF550L	A/D		FX550	A/D		NF550		T580		
A.721		05		EF580			TF550L	A/D		FX550	A/D		NF550		T580		
A.741		05		EF580			TF550L	A/D		FX550	A/D		NF550		T580		
A.751		05		EF580		EX282	TF550L	A/D		FX550	A/D		NF550		T580		
CROSSLINE		07		EF580		EX282	TF550L	A/D		FX550	A/D		NF550		T580		

ALFA ROMEO

4C		13		EFB5318L			TF550L	BC		FX550	BC		NF557				
6		79	86	EF450	EF450		TF450L	A/D	TF450L	FX450	A/D	FX450	NF450	NF450	T450	T450	
33		83	94	EF450	EF450	EF380	TF450L	A/D	TF450L	FX450	A/D	FX450	NF450	NF450	T450	T450	T380
		84	94	EF450	EF450	EF380	TF450L	A/D	TF450L	FX450	A/D	FX450	NF450	NF450	T450	T450	T380
75		85	92	EF450	EF450	EF400	TF450L	A/D	TF450L	FX450	A/D	FX450	NF450	NF450	T450	T450	T400
90		84	87	EF450	EF450		TF450L	A/D	TF450L	FX450	A/D	FX450	NF450	NF450	T450	T450	
145		94	01	EF550	EF480		TF550L	A/D	TF480L	FX550	A/D	FX480	NF550	NF480	T550	T480	
146		94	01	EF550	EF480		TF550L	A/D	TF480L	FX550	A/D	FX480	NF550	NF480	T550	T480	
147		01	05	EF550	EF400		TF550L	A/D	TF400L	FX550	A/D	FX400	NF550	NF400	T550	T400	
		05	09	EFB556	EFB406		TF550L	BC	TF400L	FX550	BC+E	FX400	NF556	NF406			
155		92	97	EF530	EF480		TF530L	A/D	TF480L	FX530	A/D	FX480	NF530	NF480	T530	T480	
156		97	05	EF550	EF530		TF550L	A/D	TF530L	FX550	A/D	FX530	NF550	NF530	T550	T530	
		97	06	EF550	EF530		TF550L	A/D	TF530L	FX550	A/D	FX530	NF550	NF530	T550	T530	
159		05	11	EFB556	EFB456		TF550L	BC	TF450L	FX550	BC+E	FX450	NF556	NF456			
		06	11	EFB556	EFB456		TF550L	BC	TF450L	FX550	BC+E	FX450	NF556	NF456			
164		87	98	EF530	EF530		TF530L	A/D	TF530L	FX530	A/D	FX530	NF530	NF530	T530	T530	
166		98	07	EF530	EF480		TF530L	A/D	TF480L	FX530	A/D	FX480	NF530	NF480	T530	T480	





...ALFA ROMEO

1750-2000	68	83	EF330	EF330										T330	T330		
ALFASUD		72	84	EF380	EF380	EF380	TF350L	A/D	TF350L	FX350	A/D	FX350	NF350	NF350	T380	T380	T380
		78	81	EF380	EF380	EF380	TF350L	A/D	TF350L	FX350	A/D	FX350	NF350	NF350	T380	T380	T380
		76	89	EF380	EF380		TF350L	A/D	TF350L	FX350	A/D	FX350	NF350	NF350	T380	T380	
ALFETTA		74	84	EF400*	EF400*										T400*	T400*	
		74	86	EF400*	EF400*										T400*	T400*	
ARNA		83	86	EF500	EF500		TF500L	A/D	TF500L	FX500	A/D	FX500	NF500	NF500	T500	T500	
BRERA		06		EFB556	EFB456		TF550L	BC	TF450L	FX550	BC+E	FX450	NF556	NF456			
GIULIA		62	78	EF330	EF330										T330	T330	
		62	78	EF330	EF330										T330	T330	
GIULIETTA		77	85	EF400	EF400		TF400L	A/D	TF400L	FX400	A/D	FX400	NF400	NF400	T400	T400	
		10		EFB6018L	EFB4518L	EX353	TF600L	BC	TF450L	FX600	BC	FX450	NF609	NF459			
GT		63	77	EF330	EF330										T330	T330	
		03	05	EF550	EF400		TF550L	A/D	TF400L	FX550	A/D	FX400	NF550	NF400	T550	T400	
		06	10	EFB556	EFB406		TF550L	BC	TF400L	FX550	BC+E	FX400	NF556	NF406			
GTV		78	87	EF400*	EF400*										T400*	T400*	
		95	05	EF553	EF453												
MITO		08		EFB6517L	EFB4017L	EX300	TF650L	BC	TF400L	FX650	BC	FX400	NF657	NF407			
SPIDER		66	77	EF330	EF330										T330	T330	
		71	93	EF400	EF400		TF400L	A/D	TF400L	FX400	A/D	FX400	NF400	NF400	T400	T400	
		95	05	EF553	EF453												
		06		EFB556	EFB456		TF550L	BC	TF450L	FX550	BC+E	FX450	NF556	NF456			

ALPINA

B3		87	92	EF500	EF500		TF500L	A/D	TF500L	FX500	A/D	FX500	NF500	NF500	T500	T500	
		93	99	EF530	EF500		TF530L	A/D	TF500L	FX530	A/D	FX500	NF530	NF500	T530	T500	
		99	06	EF580	EF500		TF550L	A/D	TF500L	FX550	A/D	FX500	NF550	NF500	T580	T500	
		87	92	EF500	EF500		TF500L	A/D	TF500L	FX500	A/D	FX500	NF500	NF500	T500	T500	
		93	99	EF530	EF500		TF530L	A/D	TF500L	FX530	A/D	FX500	NF530	NF500	T530	T500	
		00	06	EF580	EF500		TF550L	A/D	TF500L	FX550	A/D	FX500	NF550	NF500	T580	T500	
		96	99	EF530	EF500		TF530L	A/D	TF500L	FX530	A/D	FX500	NF530	NF500	T530	T500	
		99	06	EF580	EF500		TF550L	A/D	TF500L	FX550	A/D	FX500	NF550	NF500	T580	T500	
		87	92	EF500	EF500		TF500L	A/D	TF500L	FX500	A/D	FX500	NF500	NF500	T500	T500	
		93	99	EF530	EF500		TF530L	A/D	TF500L	FX530	A/D	FX500	NF530	NF500	T530	T500	
		00		EF580	EF500		TF550L	A/D	TF500L	FX550	A/D	FX500	NF550	NF500	T580	T500	
B5		05	10	EFB6017L	EFB5517L		TF600L	BC	TF550L				NF608	NF588			
		05	10	EFB6017L	EFB5517L		TF600L	BC	TF550L				NF608	NF588			
B6		83	93	EF500	EF500		TF500L	A/D	TF500L	FX500	A/D	FX500	NF500	NF500	T500	T500	
		84	87	EF450	EF450		TF450L	A/D	TF450L	FX450	A/D	FX450	NF450	NF450	T450	T450	
		78	88	EF450	EF450		TF450L	A/D	TF450L	FX450	A/D	FX450	NF450	NF450	T450	T450	
B8		95	98	EF530	EF500		TF530L	A/D	TF500L	FX530	A/D	FX500	NF530	NF500	T530	T500	
		95	98	EF500	EF500		TF500L	A/D	TF500L	FX500	A/D	FX500	NF500	NF500	T500	T500	
		95	98	EF530	EF500		TF530L	A/D	TF500L	FX530	A/D	FX500	NF530	NF500	T530	T500	
		95	98	EF530	EF500		TF530L	A/D	TF500L	FX530	A/D	FX500	NF530	NF500	T530	T500	
B9		82	85	EF450	EF450		TF450L	A/D	TF450L	FX450	A/D	FX450	NF450	NF450	T450	T450	
B10		88	95		EF600										T600		
		93	96		EF600										T600		



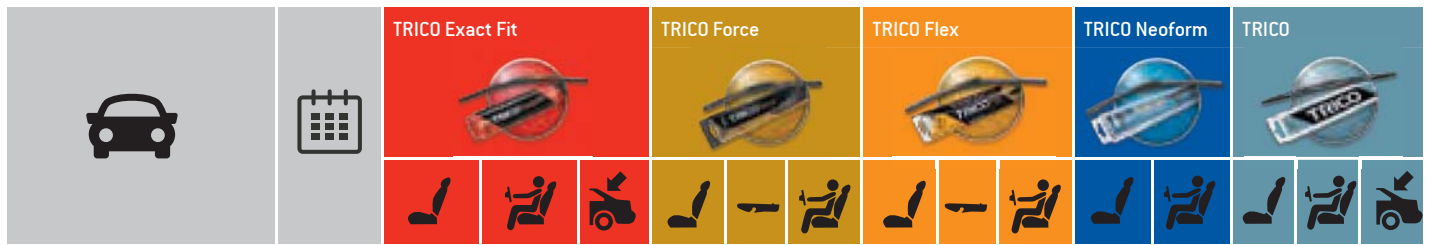

...AUDI															
...A2		02	05	EFB706			TF700L	BC		FX700	BC+E		NF706		
A3		13		EFB6017L	EFB4817L		TF600L	BC	TF480L	FX600	BC	FX480	NF6013	NF4813	
		96	03	EF530	EF480	EF380	TF530L	A/D	TF480L	FX530	A/D	FX480	NF530	NF480	T530 T480 T380
		03	04	EFB606	EFB456	EX330	TF600L	BC	TF450L	FX600	BC+E	FX450	NF606	NF456	T330
		04	12	EFB6017L	EFB4817L	EX330	TF600L	BC	TF480L	FX600	BC	FX480	NF607	NF487	T330
		12		EFB6017L	EFB4517L	EX334	TF600L	BC	TF450L	FX600	BC	FX450	NF6013	NF4513	
		08	13	EFB6017L	EFB4817L		TF600L	BC	TF480L	FX600	BC	FX480	NF607	NF487	
		14		EFB6017L	EFB4817L		TF600L	BC	TF480L	FX600	BC	FX480	NF6013	NF4813	
A4		94	00	EF530	EF530		TF530L	A/D	TF530L	FX530	A/D	FX530	NF530	NF530	T530 T530
		04	08	EFB555	EFB555								NF555	NF555	
		08		EFB6017L	EFB5017L		TF600L	BC	TF500L	FX600	BC	FX500	NF6013	NF5013	
		94	01	EF530	EF530	EF380	TF530L	A/D	TF530L	FX530	A/D	FX530	NF530	NF530	T530 T530 T380
		04	08	EFB555	EFB555	EX330							NF555	NF555	T330
		08		EFB6017L	EFB5017L	EX405	TF600L	BC	TF500L	FX600	BC	FX500	NF6013	NF5013	
		02	09	EFB555	EFB555								NF555	NF555	
A4 Allroad		09		EFB6017L	EFB5017L	EX405	TF600L	BC	TF500L	FX600	BC	FX500	NF6013	NF5013	
A5		09		EFB6017L	EFB5017L		TF600L	BC	TF500L	FX600	BC	FX500	NF6013	NF5013	
		07		EFB6017L	EFB5017L		TF600L	BC	TF500L	FX600	BC	FX500	NF6013	NF5013	
		09		EFB6017L	EFB5017L		TF600L	BC	TF500L	FX600	BC	FX500	NF6013	NF5013	
A6		94	02	EF550	EF550		TF550L	A/D	TF550L	FX550	A/D	FX550	NF550	NF550	T550 T550
		02	05	EFB555	EFB555								NF555	NF555	
		04	11	EFB5515	EFB5515								NF5515	NF5515	
		11		EFB6017L	EFB5017L		TF600L	BC	TF500L	FX600	BC	FX500	NF6013	NF5013	
		94	02	EF550	EF550	EF450	TF550L	A/D	TF550L	FX550	A/D	FX550	NF550	NF550	T550 T550 T450
		02	05	EFB555	EFB555	EF380							NF555	NF555	T380
		05	11	EFB5515	EFB5515	EX355							NF5515	NF5515	T350
		11		EFB6017L	EFB5017L	EX405	TF600L	BC	TF500L	FX600	BC	FX500	NF6013	NF5013	
A6 Allroad		06	11	EFB5515	EFB5515	EX355							NF5515	NF5515	T350
		12		EFB6017L	EFB5017L	EX405	TF600L	BC	TF500L	FX600	BC	FX500	NF6013	NF5013	
A7		10		EFB6017L	EFB5017L		TF600L	BC	TF500L	FX600	BC	FX500	NF6013	NF5013	
A8		94	02	EF550	EF550		TF550L	A/D	TF550L	FX550	A/D	FX550	NF550	NF550	T550 T550
		02	10	EFB555	EFB555								NF555	NF555	
		09		EFB6517L	EFB5017L		TF650L	BC	TF500L	FX650	BC	FX500	NF6513	NF5013	
ALLROAD		00	01	EF550	EF550	EF380	TF550L	A/D	TF550L	FX550	A/D	FX550	NF550	NF550	T550 T550 T380
		02	05	EFB555	EFB555	EF380							NF555	NF555	T380
CABRIOLET		91	00	EF550	EF530		TF550L	A/D	TF530L	FX550	A/D	FX530	NF550	NF530	T550 T530
COUPE		80	88	EF450	EF450	EF450	TF450L	A/D	TF450L	FX450	A/D	FX450	NF450	NF450	T450 T450 T450
		88	96	EF530	EF530		TF530L	A/D	TF530L	FX530	A/D	FX530	NF530	NF530	T530 T530
Q3		11		EFB6017L	EFB5017L	EX405	TF600L	BC	TF500L	FX600	BC	FX500	NF6013	NF5013	
Q5		08		EFB6017L	EFB5017L	EX334	TF600L	BC	TF500L	FX600	BC	FX500	NF6013	NF5013	
Q7		06	15	EFB6517L	EFB6517L	EX330	TF650L	BC	TF650L	FX650	BC	FX650	NF657	NF657	T330
		15		EFB6517L	EFB5017L	EX405	TF650L	BC	TF500L	FX650	BC	FX500	NF6513	NF5013	
QUATTRO		80	91	EF450	EF450	EF450	TF450L	A/D	TF450L	FX450	A/D	FX450	NF450	NF450	T450 T450 T450
TT		98	02	EF530	EF530		TF530L	A/D	TF530L	FX530	A/D	FX530	NF530	NF530	T530 T530
		03	05	EFB536	EFB506		TF530L	BC	TF500L	FX530	BC+E	FX500	NF536	NF506	
		06	14	EFB5517L	EFB5017L		TF550L	BC	TF500L	FX550	BC	FX500	NF557	NF507	

		TRICO Exact Fit			TRICO Force			TRICO Flex			TRICO Neoform		TRICO				

...AUDI

...TT	15		EFB6017L	EFB5017L		TF600L	BC	TF500L	FX600	BC	FX500	NF6013	NF5013			
	99	02	EF530	EF530		TF530L	A/D	TF530L	FX530	A/D	FX530	NF530	NF530	T530	T530	
		03	06	EFB536	EFB506		TF530L	BC	TF500L	FX530	BC+E	FX500	NF536	NF506		
		07	14	EFB5517L	EFB5017L		TF550L	BC	TF500L	FX550	BC	FX500	NF557	NF507		
		15		EFB6017L	EFB5017L		TF600L	BC	TF500L	FX600	BC	FX500	NF6013	NF5013		
V8	88	94		EF530	EF530		TF530L	A/D	TF530L	FX530	A/D	FX530	NF530	NF530	T530	T530

AUSTIN

ALLEGRO		79	84	EF350	EF350		TF350L	A/D	TF350L	FX350	A/D	FX350	NF350	NF350	T350	T350	
		73	83	EF350	EF350	EF280	TF350L	A/D	TF350L	FX350	A/D	FX350	NF350	NF350	T350	T350	T280
		75	82	EF350	EF350	EF280	TF350L	A/D	TF350L	FX350	A/D	FX350	NF350	NF350	T350	T350	T280
AMBASSADOR		82	84	EF500*	EF500*	EF500*									T500*	T500*	T500*
MAESTRO		83	92	EF500	EF500	EF500	TF500L	A/D	TF500L	FX500	A/D	FX500	NF500	NF500	T500	T500	T500
MAXI		69	80	EF350	EF350		TF350L	A/D	TF350L	FX350	A/D	FX350	NF350	NF350	T350	T350	
METRO		80	90	EF400	EF400	EF380	TF400L	A/D	TF400L	FX400	A/D	FX400	NF400	NF400	T400	T400	T380
MINI		62	93	EF280	EF280										T280	T280	
		69	85	EF280	EF280										T280	T280	
MONTEGO		84	88	EF500	EF500		TF500L	A/D	TF500L	FX500	A/D	FX500	NF500	NF500	T500	T500	
		84	92	EF500	EF500	EF350	TF500L	A/D	TF500L	FX500	A/D	FX500	NF500	NF500	T500	T500	T350

AUTOBIANCHI

A 111		69	72	EF330	EF330										T330	T330	
A 112		69	85	EF330	EF330	EF330									T330	T330	T330
Y10		85	95	EF450		EF330	TF450L	A/D		FX450	A/D		NF450		T450		T330

BEDFORD

ASTRAMAX		85	90	EF450	EF450		TF450L	A/D	TF450L	FX450	A/D	FX450	NF450	NF450	T450	T450	
ASTRA VAN		82	91	EF450	EF450		TF450L	A/D	TF450L	FX450	A/D	FX450	NF450	NF450	T450	T450	
BLITZ		69	87	EF330	EF330										T330	T330	
CHEVANNE		76	82	EF330	EF330										T330	T330	
MIDI		84	92	EF450	EF450		TF450L	A/D	TF450L	FX450	A/D	FX450	NF450	NF450	T450	T450	
RASCAL		86	90	EF400	EF400		TF400L	A/D	TF400L	FX400	A/D	FX400	NF400	NF400	T400	T400	

BENTLEY

ARNAGE		98	09	EF600	EF600		TF600L	A/D	TF600L	FX600	A/D	FX600	NF600	NF600	T600	T600	
		05		EF600	EF600		TF600L	A/D	TF600L	FX600	A/D	FX600	NF600	NF600	T600	T600	
CONTINENTAL		84	95	EF550	EF550		TF550L	A/D	TF550L	FX550	A/D	FX550	NF550	NF550	T550	T550	

BMW

1		06	11	EFB5017L	EFB5017L	EX307	TF500L	BC	TF500L	FX500	BC	FX500	NF507	NF507			
		11		EFB5517L	EFB4517L	EX306	TF550L	BC	TF450L	FX550	BC	FX450	NF557	NF459			
		07	11	EFB5017L	EFB5017L		TF500L	BC	TF500L	FX500	BC	FX500	NF507	NF507			
		08	11	EFB5017L	EFB5017L		TF500L	BC	TF500L	FX500	BC	FX500	NF507	NF507			
02		67	77	EF380	EF380		TF350L	A/D	TF350L	FX350	A/D	FX350	NF350	NF350	T380	T380	
		71	75	EF380	EF380		TF350L	A/D	TF350L	FX350	A/D	FX350	NF350	NF350	T380	T380	
		67	75	EF380	EF380		TF350L	A/D	TF350L	FX350	A/D	FX350	NF350	NF350	T380	T380	
2		13		EFB5017L	EFB4017L		TF500L	BC	TF400L	FX500	BC	FX400	NF507	NF407			
		13		EFB5017L	EFB4017L		TF500L	BC	TF400L	FX500	BC	FX400	NF507	NF407			
2 Active Tourer		14		EFB6518L	EFB4818L	EX306	TF650L	BC	TF480L	FX650	BC	FX480	NF659	NF489			
3		75	84	EF450	EF450		TF450L	A/D	TF450L	FX450	A/D	FX450	NF450	NF450	T450	T450	
		82	92	EF500	EF500		TF500L	A/D	TF500L	FX500	A/D	FX500	NF500	NF500	T500	T500	

		TRICO Exact Fit			TRICO Force			TRICO Flex			TRICO Neoform		TRICO	
--	--	------------------------	--	--	--------------------	--	--	-------------------	--	--	----------------------	--	--------------	--

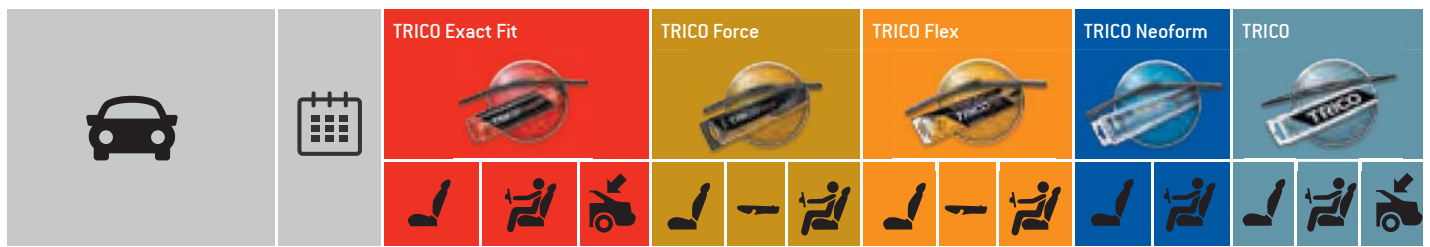

...BMW

...3	90	98	EF530	EF500		TF530L	A/D	TF500L	FX530	A/D	FX500	NF530	NF500	T530	T500	
	98	05	EF580	EF500								NF550	NF500			
	05	11	EFB606	EFB486		TF600L	BC	TF480L	FX600	BC+E	FX480	NF606	NF486			
	12		EFB6017L	EFB4817L		TF600L	BC	TF480L	FX600	BC	FX480	NF607	NF487			
	94	00	EF500	EF500	EF450							NF500	NF500			
	01	05	EF580	EF500	EF450							NF550	NF500			
	87	94	EF500	EF500	EF450	TF500L	A/D	TF500L	FX500	A/D	FX500	NF500	NF500	T500	T500	T450
	95	99	EF530	EF500	EF380							NF530	NF500			
	99	05	EF580	EF500								NF550	NF500			
	05	09	EFB606	EFB486	EX330	TF600L	BC	TF480L	FX600	BC+E	FX480	NF606	NF486			T330
	10	12	EFB6017L	EFB4817L		TF600L	BC	TF480L	FX600	BC	FX480	NF607	NF487			
	13		EFB6017L	EFB4817L	EX304	TF600L	BC	TF480L	FX600	BC	FX480	NF607	NF487			
	92	99	EF530	EF500		TF530L	A/D	TF500L	FX530	A/D	FX500	NF530	NF500	T530	T500	
	99	05	EF580	EF500								NF550	NF500			
	06	09	EFB606	EFB436		TF600L	BC	TF430L	FX600	BC+E	FX430	NF606	NF436			
	10		EFB6017L	EFB4017L		TF600L	BC	TF430L	FX600	BC	FX430	NF607	NF439			
	85	93	EF500	EF500		TF500L	A/D	TF500L	FX500	A/D	FX500	NF500	NF500	T500	T500	
	93	99	EF530	EF500								NF530	NF500			
	00	05	EF580	EF500								NF550	NF500			
	07	09	EFB606	EFB436		TF600L	BC	TF430L	FX600	BC+E	FX430	NF606	NF436			
	10		EFB6017L	EFB4017L		TF600L	BC	TF430L	FX600	BC	FX430	NF607	NF439			
3 (GT)	13		EFB6017L	EFB4817L		TF600L	BC	TF480L	FX600	BC	FX480	NF607	NF487			
4	13		EFB6017L	EFB4517L		TF600L	BC	TF450L	FX600	BC	FX450	NF607	NF459			
5	72	87	EF450	EF450		TF450L	A/D	TF450L	FX450	A/D	FX450	NF450	NF450	T450	T450	
	87	95		EF600												
	95	03	EF641	EF521												
	03	10	EFB6017L	EFB5517L		TF600L	BC	TF550L	FX600	BC	FX550	NF608	NF588			
	10		EFB6518L	EFB4518L		TF650L	BC	TF450L	FX650	BC	FX450	NF6516	NF4516			
	91	97		EF600												
	97	04	EF641	EF521												
	04	10	EFB6017L	EFB5517L	EX355	TF600L	BC	TF550L	FX600	BC	FX550	NF608	NF588			
	10		EFB6518L	EFB4518L	EX333	TF650L	BC	TF450L	FX650	BC	FX450	NF6516	NF4516			
5 GT	09		EFB6518L	EFB4518L		TF650L	BC	TF450L	FX650	BC	FX450	NF6516	NF4516			
6	76	90	EF450	EF450		TF450L	A/D	TF450L	FX450	A/D	FX450	NF450	NF450	T450	T450	
	04	10	EFB6017L	EFB5517R		TF600L	BC	TF550R	FX600	BC	FX550	NF608	NF588			
	10		EFB6518L	EFB4318L		TF650L	BC	TF430L	FX650	BC	FX430	NF6516	NF4316			
	04	10	EFB6017L	EFB5517R		TF600L	BC	TF550R	FX600	BC	FX550	NF608	NF588			
	11		EFB6518L	EFB4318L		TF650L	BC	TF430L	FX650	BC	FX430	NF6516	NF4316			
7	77	86	EF450	EF450		TF450L	A/D	TF450L	FX450	A/D	FX450	NF450	NF450	T450	T450	
	86	01		EF600												T600
	08		EFB6518L	EFB4518L		TF650L	BC	TF450L	FX650	BC	FX450	NF6516	NF4516			
2500-3.3	68	77	EF400*	EF400*										T400*	T400*	
i3	13		EFB756	EFB536	EX282	TF750L	BC	TF530L	FX750	BC+E	FX530	NF756	NF536			
X1	09		EFB6017L	EFB4017L	EX307	TF600L	BC	TF400L	FX600	BC	FX400	NF607	NF407			
X3	04	09	EF550	EF500	EX357	TF550L	A/D	TF500L	FX550	A/D	FX500	NF550	NF500	T550	T500	
	10		EFB656	EFB506	EX333	TF650L	BC	TF500L	FX650	BC+E	FX500	NF656	NF506			





...BMW

X5		00	07	EF600	EF550	EF450	TF600L	A/D	TF550L	FX600	A/D	FX550			T600	T550	T450
		07	12	EFB606	EFB506	EX400	TF600L	BC	TF500L	FX600	BC+E	FX500	NF606	NF506			
			13	HF600	HF500	EX306	TF600L	A/D	TF500L	FX600	A/D	FX500	NF600	NF500			
X6		08	12	EFB606	EFB506		TF600L	BC	TF500L	FX600	BC+E	FX500	NF606	NF506			
			13	14	EFB6018L	EFB4818L	TF600L	BC	TF500L	FX600	BC	FX500	NF609	NF509			
			15		HF600	HF500	TF600L	A/D	TF500L	FX600	A/D	FX500	NF600	NF500			
Z1		88	91	EF500	EF500		TF500L	A/D	TF500L	FX500	A/D	FX500	NF500	NF500	T500	T500	
Z3		97	03	EF500	EF500		TF500L	A/D	TF500L	FX500	A/D	FX500	NF500	NF500	T500	T500	
		95	03	EF500	EF500		TF500L	A/D	TF500L	FX500	A/D	FX500	NF500	NF500	T500	T500	
Z4		06		EF530	EF500		TF530L	A/D	TF500L	FX530	A/D	FX500	NF530	NF500	T530	T500	
		03		EF530	EF500		TF530L	A/D	TF500L	FX530	A/D	FX500	NF530	NF500	T530	T500	
Z8		00	03	EF530	EF530		TF530L	A/D	TF530L	FX530	A/D	FX530	NF530	NF530	T530	T530	

BUICK

CENTURY		75	96	EF450	EF450		TF450L	A/D	TF450L	FX450	A/D	FX450	NF450	NF450	T450	T450	
		96	05	EF550	EF550		TF550L	A/D	TF550L	FX550	A/D	FX550	NF550	NF550	T550	T550	
		77	91	EF450	EF450	EF400	TF450L	A/D	TF450L	FX450	A/D	FX450	NF450	NF450	T450	T450	T400
		81	96	EF450	EF450	EF400	TF450L	A/D	TF450L	FX450	A/D	FX450	NF450	NF450	T450	T450	T400
		86	89	EF450	EF450		TF450L	A/D	TF450L	FX450	A/D	FX450	NF450	NF450	T450	T450	
ELECTRA		81	91	EF480	EF480		TF480L	A/D	TF480L	FX480	A/D	FX480	NF480	NF480	T480	T480	
LA CROSSE		06	09	EF550	EF550		TF550L	A/D	TF550L	FX550	A/D	FX550	NF550	NF550	T550	T550	
		06		EF550	EF550		TF550L	A/D	TF550L	FX550	A/D	FX550	NF550	NF550	T550	T550	
LE SABRE		85	91	EF450	EF450		TF450L	A/D	TF450L	FX450	A/D	FX450	NF450	NF450	T450	T450	
		91	99	EF550	EF550		TF550L	A/D	TF550L	FX550	A/D	FX550	NF550	NF550	T550	T550	
PARK AVENUE		90	96	EF550	EF550		TF550L	A/D	TF550L	FX550	A/D	FX550	NF550	NF550	T550	T550	
REGAL		87	97	EF450	EF450		TF450L	A/D	TF450L	FX450	A/D	FX450	NF450	NF450	T450	T450	
		97	04	EF550	EF550		TF550L	A/D	TF550L	FX550	A/D	FX550	NF550	NF550	T550	T550	
ROADMASTER		92	96	EF550	EF550		TF550L	A/D	TF550L	FX550	A/D	FX550	NF550	NF550	T550	T550	
		90	96	EF550	EF550	EF550	TF550L	A/D	TF550L	FX550	A/D	FX550	NF550	NF550	T550	T550	T550
SKYLARK		79	95	EF480	EF480		TF480L	A/D	TF480L	FX480	A/D	FX480	NF480	NF480	T480	T480	

CADILLAC

ALLANTE		91	93	EF500	EF500		TF500L	A/D	TF500L	FX500	A/D	FX500	NF500	NF500	T500	T500	
		88	93	EF500	EF500		TF500L	A/D	TF500L	FX500	A/D	FX500	NF500	NF500	T500	T500	
BLS		06		EFB5517L	EFB5517L		TF550L	BC	TF550L	FX550	BC	FX550	NF557	NF557			
		07		EFB5517L	EFB5517L	EX308	TF550L	BC	TF550L	FX550	BC	FX550	NF557	NF557			
CTS		02	07	EF550	EF530		TF550L	A/D	TF530L	FX550	A/D	FX530	NF550	NF530	T550	T530	
		08	13	EF550	EF480		TF550L	A/D	TF480L	FX550	A/D	FX480	NF550	NF480	T550	T480	
			14		EFB6518L	EFB4518L	TF650L	BC	TF450L	FX650	BC	FX450	NF659	NF459			
		08	13	EF550	EF480	EX281	TF550L	A/D	TF480L	FX550	A/D	FX480	NF550	NF480	T550	T480	T280
			14		EFB6518L	EFB4518L	TF650L	BC	TF450L	FX650	BC	FX450	NF659	NF459			
		08	13	EF550	EF480		TF550L	A/D	TF480L	FX550	A/D	FX480	NF550	NF480	T550	T480	
			14		EFB6518L	EFB4518L	TF650L	BC	TF450L	FX650	BC	FX450	NF659	NF459			
DTS		05		EF550	EF550		TF550L	A/D	TF550L	FX550	A/D	FX550	NF550	NF550	T550	T550	
ELDORADO		87	02	EF550	EF550		TF550L	A/D	TF550L	FX550	A/D	FX550	NF550	NF550	T550	T550	
ELR		14		EFB6518L	EFB6518L		TF650L	BC	TF650L	FX650	BC	FX650	NF659	NF659			
ESCALADE		98	99	EFB5517L	EFB5517L		TF550L	BC	TF550L	FX550	BC	FX550	NF557	NF557			
		98	06	EFB6517L	EFB6517L		TF650L	BC	TF650L	FX650	BC	FX650	NF657	NF657			



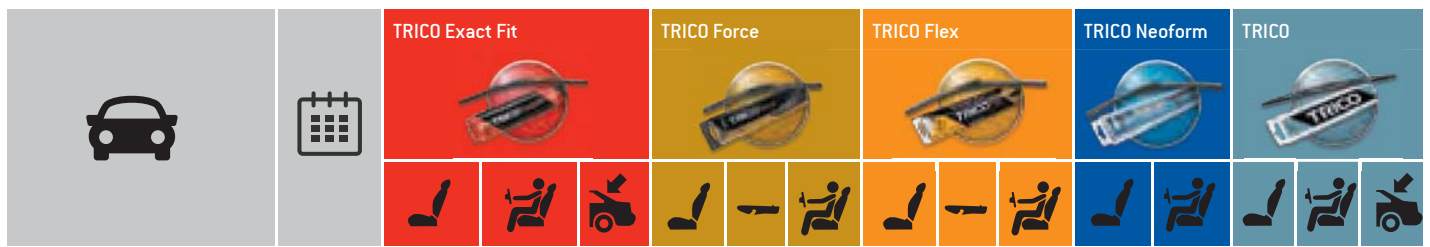

...CADILLAC

...ESCALADE	06	13	EF550	EF550		TF550L	A/D	TF550L	FX550	A/D	FX550	NF550	NF550	T550	T550	
	14		HF550	HF550	EF330	TF550L	A/D	TF550L	FX550	A/D	FX550	NF550	NF550	T550	T550	T330
SEVILLE	79		EF480	EF480		TF480L	A/D	TF480L	FX480	A/D	FX480	NF480	NF480	T480	T480	
	93	97	EF550	EF550		TF550L	A/D	TF550L	FX550	A/D	FX550	NF550	NF550	T550	T550	
	00	04	EF550	EF550		TF550L	A/D	TF550L	FX550	A/D	FX550	NF550	NF550	T550	T550	
SRX	04	08	EF550	EF530	EF330	TF550L	A/D	TF530L	FX550	A/D	FX530	NF550	NF530	T550	T530	T330
	09		EFB6518L	EFB4318L		TF650L	BC	TF430L	FX650	BC	FX430	NF659	NF439			
STS	05		EFB5517L	EFB5317L		TF550L	BC	TF530L	FX550	BC	FX530	NF557	NF537			
XLR	04	09	EF500	EF500		TF500L	A/D	TF500L	FX500	A/D	FX500	NF500	NF500	T500	T500	

CATERHAM

21	94		EF480	EF480		TF480L	A/D	TF480L	FX480	A/D	FX480	NF480	NF480	T480	T480	
----	----	--	-------	-------	--	--------	-----	--------	-------	-----	-------	-------	-------	------	------	--

CHEVROLET

ALERO	99	04	EF550	EF430		TF550L	A/D	TF430L	FX550	A/D	FX430	NF550	NF430	T550	T430		
ASTRO	84	94	EF450	EF450		TF450L	A/D	TF450L	FX450	A/D	FX450	NF450	NF450	T450	T450		
AVALANCHE	00	06	EF550	EF550		TF550L	A/D	TF550L	FX550	A/D	FX550	NF550	NF550	T550	T550		
AVEO		04	10	EF550	EF450		TF550L	A/D	TF450L	FX550	A/D	FX450	NF550	NF450	T550	T450	
		11		EFB6517L	EFB4017L		TF650L	BC	TF400L	FX650	BC	FX400	NF657	NF407			
		08	10	EF550	EF450		TF550L	A/D	TF450L	FX550	A/D	FX450	NF550	NF450	T550	T450	
		11		EFB6517L	EFB4017L		TF650L	BC	TF400L	FX650	BC	FX400	NF657	NF407			
BERETTA	87	96	EF480	EF480		TF480L	A/D	TF480L	FX480	A/D	FX480	NF480	NF480	T480	T480		
BLAZER	93	05	EF500	EF500	EF350	TF500L	A/D	TF500L	FX500	A/D	FX500	NF500	NF500	T500	T500	T350	
BLAZER S	82	94	EF400	EF400	EF400	TF400L	A/D	TF400L	FX400	A/D	FX400	NF400	NF400	T400	T400	T400	
BLAZER S10	94	98	EF500	EF500	EF350	TF500L	A/D	TF500L	FX500	A/D	FX500	NF500	NF500	T500	T500	T350	
BLAZER S10 Van	94	02	EF500	EF500		TF500L	A/D	TF500L	FX500	A/D	FX500	NF500	NF500	T500	T500		
C1500		91	96	EF450	EF450	EF450	TF450L	A/D	TF450L	FX450	A/D	FX450	NF450	NF450	T450	T450	T450
C1500 Van	91	96	EF450	EF450		TF450L	A/D	TF450L	FX450	A/D	FX450	NF450	NF450	T450	T450		
C2500		91	96	EF450	EF450	EF450	TF450L	A/D	TF450L	FX450	A/D	FX450	NF450	NF450	T450	T450	T450
C2500 Van	91	96	EF450	EF450		TF450L	A/D	TF450L	FX450	A/D	FX450	NF450	NF450	T450	T450		
C3500	93	96	EF450	EF450	EF450	TF450L	A/D	TF450L	FX450	A/D	FX450	NF450	NF450	T450	T450	T450	
CAMARO		70	98	EF450	EF450		TF450L	A/D	TF450L	FX450	A/D	FX450	NF450	NF450	T450	T450	
		98	02	EF600	EF600		TF600L	A/D	TF600L	FX600	A/D	FX600	NF600	NF600	T600	T600	
		88	97	EF450	EF450		TF450L	A/D	TF450L	FX450	A/D	FX450	NF450	NF450	T450	T450	
		97	02	EF600	EF600		TF600L	A/D	TF600L	FX600	A/D	FX600	NF600	NF600	T600	T600	
CAPRICE	70	90	EF450	EF450		TF450L	A/D	TF450L	FX450	A/D	FX450	NF450	NF450	T450	T450		
CAPRICE CLASSIC	86	96	EF450	EF450		TF450L	A/D	TF450L	FX450	A/D	FX450	NF450	NF450	T450	T450		
CAPTIVA	06		EF600	EF400		TF600L	A/D	TF400L	FX600	A/D	FX400	NF600	NF400	T600	T400		
CAVALIER		89	05	EF400	EF400		TF400L	A/D	TF400L	FX400	A/D	FX400	NF400	NF400	T400	T400	
		89	05	EF400	EF400		TF400L	A/D	TF400L	FX400	A/D	FX400	NF400	NF400	T400	T400	
		89	03	EF550	EF430		TF550L	A/D	TF430L	FX550	A/D	FX430	NF550	NF430	T550	T430	
COBALT		04		EF550	EF430		TF550L	A/D	TF430L	FX550	A/D	FX430	NF550	NF430	T550	T430	
		04		EF550	EF430		TF550L	A/D	TF430L	FX550	A/D	FX430	NF550	NF430	T550	T430	
COLORADO	03		EF550	EF480		TF550L	A/D	TF480L	FX550	A/D	FX480	NF550	NF480	T550	T480		
CORSICA	87	96	EF480	EF480		TF480L	A/D	TF480L	FX480	A/D	FX480	NF480	NF480	T480	T480		
CORVETTE		90	97	EF500	EF500		TF500L	A/D	TF500L	FX500	A/D	FX500	NF500	NF500	T500	T500	
		97	04	EF550	EF550		TF550L	A/D	TF550L	FX550	A/D	FX550	NF550	NF550	T550	T550	
		04	13	EF530	EF530		TF530L	A/D	TF530L	FX530	A/D	FX530	NF530	NF530	T530	T530	



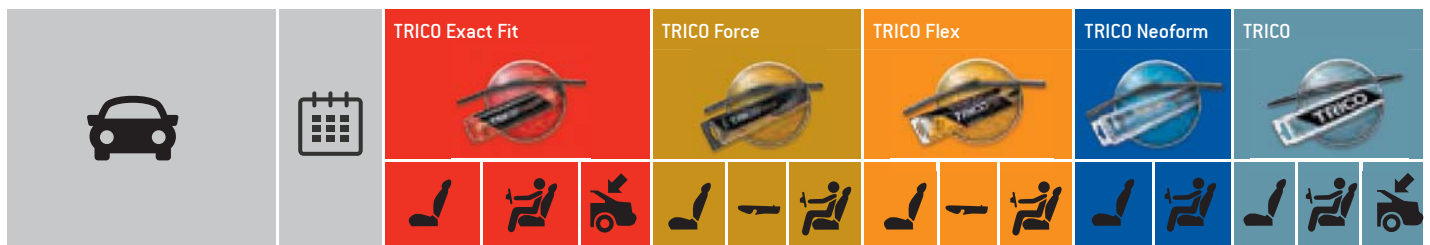

...CHEVROLET

...CORVETTE	14		HF550	HF500		TF550L	A/D	TF500L	FX550	A/D	FX500	NF550	NF500	T550	T500	
	85	97	EF480	EF480		TF480L	A/D	TF480L	FX480	A/D	FX480	NF480	NF480	T480	T480	
	97	04	EF550	EF550		TF550L	A/D	TF550L	FX550	A/D	FX550	NF550	NF550	T550	T550	
	04	13	EF530	EF530		TF530L	A/D	TF530L	FX530	A/D	FX530	NF530	NF530	T530	T530	
	14		HF550	HF500		TF550L	A/D	TF500L	FX550	A/D	FX500	NF550	NF500	T550	T500	
CRUZE		09	EF600	EF450		TF600L	A/D	TF450L	FX600	A/D	FX450	NF600	NF400	T600	T450	
	09		EF600	EF450		TF600L	A/D	TF450L	FX600	A/D	FX450	NF600	NF450	T600	T450	
	12		EF600	EF450		TF600L	A/D	TF450L	FX600	A/D	FX450	NF600	NF450	T600	T450	
EPICA	05		EF550	EF500		TF550L	A/D	TF500L	FX550	A/D	FX500	NF550	NF500	T550	T500	
EQUINOX	03	09	EF600	EF480	EF380	TF600L	A/D	TF480L	FX600	A/D	FX480	NF600	NF480	T600	T480	T380
EVANDA	05		EF550	EF500		TF550L	A/D	TF500L	FX550	A/D	FX500	NF550	NF500	T550	T500	
EXPRESS	95	98	EF550	EF550		TF550L	A/D	TF550L	FX550	A/D	FX550	NF550	NF550	T550	T550	
	07		EF550	EF550		TF550L	A/D	TF550L	FX550	A/D	FX550	NF550	NF550	T550	T550	
G20	89	96	EF400	EF400		TF400L	A/D	TF400L	FX400	A/D	FX400	NF400	NF400	T400	T400	
G20 CHEVY	87	93	EF400	EF400		TF400L	A/D	TF400L	FX400	A/D	FX400	NF400	NF400	T400	T400	
G30	89	94	EF400	EF400		TF400L	A/D	TF400L	FX400	A/D	FX400	NF400	NF400	T400	T400	
HHR	06		EF450	EF450		TF450L	A/D	TF450L	FX450	A/D	FX450	NF450	NF450	T450	T450	
IMPALA	99	05	EF550	EF550		TF550L	A/D	TF550L	FX550	A/D	FX550	NF550	NF550	T550	T550	
KALOS		05	EF550	EF400		TF550L	A/D	TF400L	FX550	A/D	FX400	NF550	NF400	T550	T400	
	05		EF550	EF400	EF380	TF550L	A/D	TF400L	FX550	A/D	FX400	NF550	NF400	T550	T400	T380
LACETTI	05		EF550	EF480	EF450	TF550L	A/D	TF480L	FX550	A/D	FX480	NF550	NF480	T550	T480	T450
MALIBU		80	83	EF450	EF450		TF450L	A/D	TF450L	FX450	A/D	FX450	NF450	NF450	T450	T450
	96	03	EF550	EF480		TF550L	A/D	TF480L	FX550	A/D	FX480	NF550	NF480	T550	T480	
	03	07	EF550	EF500		TF550L	A/D	TF500L	FX550	A/D	FX500	NF550	NF500	T550	T500	
	12		HF600	HF480		TF600L	A/D	TF480L	FX600	A/D	FX480	NF600	NF480			
	03	08	EF550	EF500		TF550L	A/D	TF500L	FX550	A/D	FX500	NF550	NF500	T550	T500	
MATIZ	05	10	EF550	EF350		TF550L	A/D	TF350L	FX550	A/D	FX350	NF550	NF350	T550	T350	
MERIVA	02		EF600	EF600	EX404	TF600L	A/D	TF600L	FX600	A/D	FX600	NF600	NF600	T600	T600	
MONTE CARLO	70	81	EF400	EF400		TF400L	A/D	TF400L	FX400	A/D	FX400	NF400	NF400	T400	T400	
NUBIRA		05	EF550	EF480		TF550L	A/D	TF480L	FX550	A/D	FX480	NF550	NF480	T550	T480	
	05		EF550	EF480		TF550L	A/D	TF480L	FX550	A/D	FX480	NF550	NF480	T550	T480	
OPTRA	99		EF550	EF480		TF550L	A/D	TF480L	FX550	A/D	FX480	NF550	NF480	T550	T480	
ORLANDO	11		EF600	EF480		TF600L	A/D	TF480L	FX600	A/D	FX480	NF600	NF480	T600	T480	
PRIZM	97	01	EF500	EF450		TF500L	A/D	TF450L	FX500	A/D	FX450	NF500	NF450	T500	T450	
REZZO	05		EF600	EF480	EF380	TF600L	A/D	TF480L	FX600	A/D	FX480	NF600	NF480	T600	T480	T380
S10 Pick Up	82	05	EF500	EF500		TF500L	A/D	TF500L	FX500	A/D	FX500	NF500	NF500	T500	T500	
SILVERADO	97		EF550	EF550		TF550L	A/D	TF550L	FX550	A/D	FX550	NF550	NF550	T550	T550	
SPARK	05	09	EF550	EF350		TF550L	A/D	TF350L	FX550	A/D	FX350	NF550	NF350	T550	T350	
	10		EF580	EF380		TF550L	A/D	TF350L	FX550	A/D	FX350	NF550	NF350	T580	T380	
STINGRAY	14		HF550	HF500		TF550L	A/D	TF500L	FX550	A/D	FX500	NF550	NF500			
SUBURBAN		91	96	EF450	EF450									T450	T450	
SUV	84	00	EF450	EF450										T450	T450	
	00	07	EF550	EF550										T550	T550	
	06		EFB5517L	EFB5517L		TF550L	BC	TF550L	FX550	BC	FX550	NF557	NF557			
TAHOE	94	99	EF450	EF450	EF400	TF450L	A/D	TF450L	FX450	A/D	FX450	NF450	NF450	T450	T450	T400
	99	06	EF450	EF450	EF400	TF450L	A/D	TF450L	FX450	A/D	FX450	NF450	NF450	T450	T450	T400





...CHEVROLET

TRACKER	98	07	EF480	EF480	EF380	TF480L	A/D	TF480L	FX480	A/D	FX480	NF480	NF480	T480	T480	T380
TRAILBLAZER	01	08	EF550	EF550	EF400	TF550L	A/D	TF550L	FX550	A/D	FX550	NF550	NF550	T550	T550	T400
TRANS SPORT	96	05	EF600	EF600	EF400	TF600L	A/D	TF600L	FX600	A/D	FX600	NF600	NF600	T600	T600	T400
TRAX	13		EFB6518L	EFB3518L		TF650L	BC	TF350L	FX650	BC	FX350	NF659	NF359			
UPLANDER	04		EF600	EF550	EF400	TF600L	A/D	TF550L	FX600	A/D	FX550	NF600	NF550	T600	T550	T400
VENTURE	98	04	EF600	EF600	EF400	TF600L	A/D	TF600L	FX600	A/D	FX600	NF600	NF600	T600	T600	T400
VOLT	11		EFB6518L	EFB6518L		TF650L	BC	TF650L	FX650	BC	FX650	NF659	NF659			
ZAFIRA	00		EF600	EF580	EX404	TF600L	A/D	TF550L	FX600	A/D	FX550	NF600	NF550	T600	T550	

CHRYSLER

300 C		04	12	EF550	EF550		TF550L	A/D	TF550L	FX550	A/D	FX550	NF550	NF550	T550	T550	
		04	10	EF550	EF550		TF550L	A/D	TF550L	FX550	A/D	FX550	NF550	NF550	T550	T550	
300 M		98	04	EF600	EF550		TF600L	A/D	TF550L	FX600	A/D	FX550	NF600	NF550	T600	T550	
CARAVAN		95	00	EF700	EF700	EF450	TF700L	A/D	TF700L	FX700	A/D	FX700	NF700	NF700	T700	T700	T450
CIRRUS		94	07	EF550	EF550		TF550L	A/D	TF550L	FX550	A/D	FX550	NF550	NF550	T550	T550	
CONCORDE		92	03	EF600	EF550		TF600L	A/D	TF550L	FX600	A/D	FX550	NF600	NF550	T600	T550	
CROSSFIRE		03	07	EF500	EF550		TF500L	A/D	TF550L	FX500	A/D	FX550	NF500	NF550	T500	T550	
		04	07	EF500	EF550		TF500L	A/D	TF550L	FX500	A/D	FX550	NF500	NF550	T500	T550	
DELTA		11		EFB6018L	EFB4318L	EX300	TF600L	BC	TF430L	FX600	BC	FX430	NF609	NF439			
GS		87	92	EF450	EF450		TF450L	A/D	TF450L	FX450	A/D	FX450	NF450	NF450	T450	T450	
LE BARON		86	94	EF450	EF450		TF450L	A/D	TF450L	FX450	A/D	FX450	NF450	NF450	T450	T450	
		86	96	EF450	EF450		TF450L	A/D	TF450L	FX450	A/D	FX450	NF450	NF450	T450	T450	
NEON		94	00	EF530	EF450		TF530L	A/D	TF450L	FX530	A/D	FX450	NF530	NF450	T530	T450	
		99		EF550	EF480		TF550L	A/D	TF480L	FX550	A/D	FX480	NF550	NF480	T550	T480	
NEW YORKER		93	98	EF600	EF600		TF600L	A/D	TF600L	FX600	A/D	FX600	NF600	NF600	T600	T600	
PACIFICA		03	08	EF550	EF550	EF350	TF550L	A/D	TF550L	FX550	A/D	FX550	NF550	NF550	T550	T550	T350
PT CRUISER		00	10	EF500	EF530	EF400	TF500L	A/D	TF530L	FX500	A/D	FX530	NF500	NF530	T500	T530	T400
		04	08	EF500	EF530		TF500L	A/D	TF530L	FX500	A/D	FX530	NF500	NF530	T500	T530	
SEBRING		01	07	EF550	EF550		TF550L	A/D	TF550L	FX550	A/D	FX550	NF550	NF550	T550	T550	
		07	10				TF600L	A/D	TF550L	FX600	A/D	FX550	NF600	NF550			
		95	00	EF600	EF550		TF600L	A/D	TF550L	FX600	A/D	FX550	NF600	NF550	T600	T550	
		07	10				TF600L	A/D	TF550L	FX600	A/D	FX550	NF600	NF550			
STRATUS		95		EF550	EF550		TF550L	A/D	TF550L	FX550	A/D	FX550	NF550	NF550	T550	T550	
		96	01	EF550	EF550		TF550L	A/D	TF550L	FX550	A/D	FX550	NF550	NF550	T550	T550	
TOWN & COUNTRY		00	07	EF700	EF700	EF450	TF700L	A/D	TF700L	FX700	A/D	FX700	NF700	NF700	T700	T700	T450
VISION		93	97	EF600	EF600		TF600L	A/D	TF600L	FX600	A/D	FX600	NF600	NF600	T600	T600	
VOYAGER		87	95	EF450	EF450	EF450	TF450L	A/D	TF450L	FX450	A/D	FX450	NF450	NF450	T450	T450	T450
		94	00	EF700	EF700	EF450	TF700L	A/D	TF700L	FX700	A/D	FX700	NF700	NF700	T700	T700	T450
		00	08	EF700	EF700		TF700L	A/D	TF700L	FX700	A/D	FX700	NF700	NF700	T700	T700	
		08		EF650	EF550		TF650L	A/D	TF550L	FX650	A/D	FX550	NF650	NF550	T650	T550	
YPSILON		11		EFB5318L	EFB3518L		TF550L	BC	TF350L	FX550	BC	FX350	NF539	NF359			

CITROËN

AX		86	98	EF550		EF400	TF550L	A/D		FX550	A/D		NF550		T550		T400
AXEL		81	91	EF500	EF500	EF500	TF500L	A/D	TF500L	FX500	A/D	FX500	NF500	NF500	T500	T500	T500
BERLINGO	MPV	96	07	EF550	EF550	EF400	TF550L	A/D	TF550L	FX550	A/D	FX550	NF550	NF550	T550	T550	T400
		08		EFB6518L	EFB4018L	EX353	TF650L	BC	TF400L	FX650	BC	FX400	NF659	NF409			
BERLINGO Van		96	07	EF550	EF550	EF400	TF550L	A/D	TF550L	FX550	A/D	FX550	NF550	NF550	T550	T550	T400



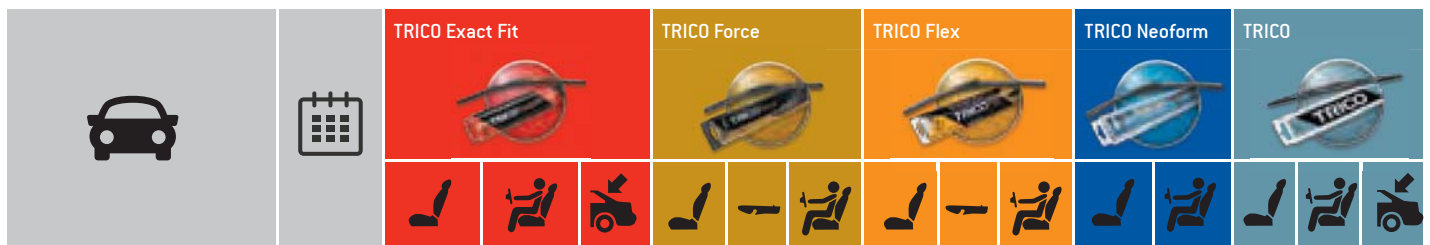

...CITROËN																	
BERLINGO Van		08		EFB6518L	EFB4018L	EX353	TF650L	BC	TF400L	FX650	BC	FX400	NF659	NF409			
BX		82	94	EF500		EF500	TF500L	A/D		FX500	A/D		NF500		T500		T500
		83	94	EF500		EF500	TF500L	A/D		FX500	A/D		NF500		T500		T500
C1		05	13	EF650		EX301	TF650L	A/D		FX650	A/D		NF650		T650		
		14		EFB6517L		EX305	TF650L	BC		FX650	BC		NF657				
C2		03	09	EF600	EF450	EX282	TF600L	A/D	TF450L	FX600	A/D	FX450	NF600	NF450	T600	T450	
C2 Van		05		EF600	EF450		TF600L	A/D	TF450L	FX600	A/D	FX450	NF600	NF450	T600	T450	
C3		02	09	EF600	EF450	EX353	TF600L	A/D	TF450L	FX600	A/D	FX450	NF600	NF450	T600	T450	
		09		EFB6514L	EFB4014L	EX282	TF650L	F	TF400L	FX650	E1	FX400	NF6514	NF4014			
		03		EF550	EF450		TF550L	A/D	TF450L	FX550	A/D	FX450	NF550	NF450	T550	T450	
C3 PICASSO		09	10	EFB6018L	EFB4018L	EX282	TF600L	BC	TF400L	FX600	BC	FX400	NF609	NF409			
C3 PICASSO		11		EFB6014L	EFB4014L	EX282	TF600L	F	TF400L	FX600	E1	FX400	NF6014	NF4014			
C4		04	09	EFB7017L	EFB6017R	EX308	TF700L	BC	TF600R	FX700	BC	FX600	NF707	NF607			
		09		EFB7518L	EFB6518R	EX282	TF750L	BC	TF650R	FX750	BC	FX650	NF759	NF659			
		04	10	EFB7017L	EFB6017R	EX180	TF700L	BC	TF600R	FX700	BC	FX600	NF707	NF607			
C4 AIRCROSS		12		HF600	HF530	EX252	TF600L	A/D	TF530L	FX600	A/D	FX530	NF600	NF530			
C4 CACTUS		14				EX254											
C4 GRAND PICASSO		06	08	EFB806	EFB756	EX357	TF800L	BC	TF750R	FX800	BC+E	FX750	NF806	NF756			
		08	13	EFB8014L	EFB7514R	EX357	TF800L	F	TF750R	FX800	E1	FX750	NF8014	NF7514			
		14		EFB8018L	EFB7518R	EX308	TF800L	BC	TF750R	FX800	BC	FX750	NF809	NF759			
C4 PICASSO		06	08	EFB806	EFB756	EX357	TF800L	BC	TF750R	FX800	BC+E	FX750	NF806	NF756			
		08	13	EFB8014L	EFB7514R	EX357	TF800L	F	TF750R	FX800	E1	FX750	NF8014	NF7514			
		14		EFB8018L	EFB7518R	EX357	TF800L	BC	TF750R	FX800	BC	FX750	NF809	NF759			
C5		08		EFB7017L	EFB5517R		TF700L	BC	TF550R	FX700	BC	FX550	NF707	NF557			
		01	04	EF650	EF480	EX500	TF650L	A/D	TF450L	FX650	A/D	FX450	NF650	NF450	T650	T480	
		04	08	EFB656	EFB456	EX400	TF650L	BC	TF450L	FX650	BC+E	FX450	NF656	NF456			
		01	04	EF650	EF480	EX282	TF650L	A/D	TF450L	FX650	A/D	FX450	NF650	NF450	T650	T480	
		04	08	EFB656	EFB456	EX282	TF650L	BC	TF450L	FX650	BC+E	FX450	NF656	NF456			
		08		EFB7017L	EFB5517R	EX253	TF700L	BC	TF550R	FX700	BC	FX550	NF707	NF557			
C6		05		EFB706	EFB706		TF700L	BC	TF700R	FX700	BC+E	FX700	NF706	NF706			
C8		02	06	EF653	EF653	EX353											
		06		EF650	EF650	EX353	TF650L	A/D	TF650R	FX650	A/D	FX650	NF650	NF650	T650	T650	
C15		87	00	EF450			TF450L	A/D		FX450	A/D		NF450		T450		
C15 Van		84	05	EF450			TF450L	A/D		FX450	A/D		NF450		T450		
C25		81	94	EF500	EF500	EF380	TF500L	A/D	TF500L	FX500	A/D	FX500	NF500	NF500	T500	T500	T380
		81	94	EF500	EF500	EF500	TF500L	A/D	TF500L	FX500	A/D	FX500	NF500	NF500	T500	T500	T500
C35		73	94	EF500	EF500		TF500L	A/D	TF500L	FX500	A/D	FX500	NF500	NF500	T500	T500	
C-CROSSER	SUV	07		HF600	HF530	EX306	TF600L	A/D	TF530L	FX600	A/D	FX530	NF600	NF530			
C-CROSSER Van		09		HF600	HF530	EX306	TF600L	A/D	TF500L	FX600	A/D	FX500	NF600	NF500			
CX		74	92	EF600			TF600L	A/D		FX600	A/D		NF600		T600		
		75	92	EF600		EF400	TF600L	A/D		FX600	A/D		NF600		T600		T400
C-ZERO		10		HF700		EX306	TF700L	A/D		FX700	A/D		NF700				
DS3		09		EFB6014L	EFB4014L	EX282	TF600L	F	TF400L	FX600	E1	FX400	NF6014	NF4014			
DS4		11		EFB7518L	EFB6518R	EX180	TF750L	BC	TF650R	FX750	BC	FX650	NF759	NF659			
DS5		11		EFB7518L	EFB6018R	EX180	TF750L	BC	TF600R	FX750	BC	FX600	NF759	NF609			
EVASION		94	02	EF650	EF500	EF400	TF650L	A/D	TF500L	FX650	A/D	FX500	NF650	NF500	T650	T500	T400



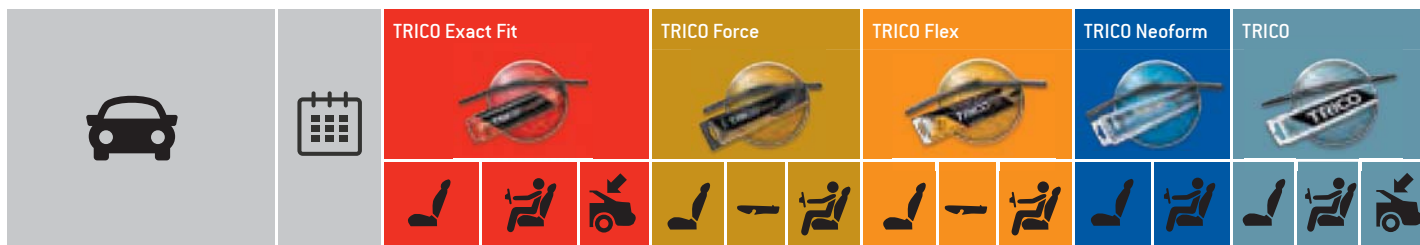

...CITROËN

GS		70	86	EF400	EF400	EF400	TF400L	A/D	TF400L	FX400	A/D	FX400	NF400	NF400	T400	T400	T400
		71	86	EF400	EF400	EF400	TF400L	A/D	TF400L	FX400	A/D	FX400	NF400	NF400	T400	T400	T400
JUMPER		94	06	EF550	EF550		TF550L	A/D	TF550L	FX550	A/D	FX550	NF550	NF550	T550	T550	
		06		EFB6518L	EFB5318L		TF650L	BC	TF550L	FX650	BC	FX550	NF659	NF539			
JUMPY	MPV	95	07	EF650	EF500	EF400	TF650L	A/D	TF500L	FX650	A/D	FX500	NF650	NF500	T650	T500	T400
		07		EF700	EF500	EX404	TF700L	A/D	TF500L	FX700	A/D	FX500	NF700	NF500	T700	T500	
JUMPY Van		07		EF700	EF500	EX404	TF700L	A/D	TF500L	FX700	A/D	FX500	NF700	NF500	T700	T500	
LNA		76	86	EF400	EF400	EF400									T400	T400	T400
MEHARI		68	87	EF280	EF280										T280	T280	
NEMO		09		EFB6514L	EFB4514L		TF650L	F	TF450L	FX650	E1		NF6514	NF4514			
NEMO Van		08		EFB6514L	EFB4014L		TF650L	F	TF400L	FX650	E1		NF6514	NF4014			
SAXO		96	04	EF500	EF450	EX353	TF500L	A/D	TF450L	FX500	A/D	FX450	NF500	NF450	T500	T450	
SM		70	74	EF500	EF500		TF500L	A/D	TF500L	FX500	A/D	FX500	NF500	NF500	T500	T500	
VISA		78	91	EF450			TF450L	A/D		FX450	A/D		NF450		T450		T450
		83	88	EF450			TF450L	A/D		FX450	A/D		NF450		T450		
XANTIA		93	03	EF600	EF480	EF400	TF600L	A/D	TF480L	FX600	A/D	FX480	NF600	NF480	T600	T480	T400
		95	03	EF600	EF480	EF400	TF600L	A/D	TF480L	FX600	A/D	FX480	NF600	NF480	T600	T480	T400
XM		89	94	EF550	EF550	EF450	TF550L	A/D	TF550L	FX550	A/D	FX550	NF550	NF550	T550	T550	T450
		94	00	EF550	EF550	EF400	TF550L	A/D	TF550L	FX550	A/D	FX550	NF550	NF550	T550	T550	T400
		89	00	EF550	EF550	EF400	TF550L	A/D	TF550L	FX550	A/D	FX550	NF550	NF550	T550	T550	T400
XSARA		97	05	EF550	EF500	EF450	TF550L	A/D	TF500L	FX550	A/D	FX500	NF550	NF500	T550	T500	T450
		97	05	EF550	EF500	EX404	TF550L	A/D	TF500L	FX550	A/D	FX500	NF550	NF500	T550	T500	
		98	05	EF550	EF500	EF450	TF550L	A/D	TF500L	FX550	A/D	FX500	NF550	NF500	T550	T500	T450
		99	05	EF650	EF650	EX404	TF650L	A/D	TF650R	FX650	A/D	FX650	NF650	NF650	T650	T650	
		05	10	EFB656	EFB656	EX404	TF650L	BC	TF650R	FX650	BC+E	FX650	NF656	NF656			
XSARA Van		00	05	EF550	EF500		TF550L	A/D	TF500L	FX550	A/D	FX500	NF550	NF500	T550	T500	
ZX		91	97	EF550		EF450	TF550L	A/D		FX550	A/D		NF550		T550		T450
		93	98	EF550		EF350	TF550L	A/D		FX550	A/D		NF550		T550		T350

DACIA

130		72	83	EF380	EF380		TF350L	A/D	TF350L	FX350	A/D	FX350	NF350	NF350	T380	T380	
1210		83	94	EF380	EF380		TF350L	A/D	TF350L	FX350	A/D	FX350	NF350	NF350	T380	T380	
1300		72	83	EF380	EF380		TF350L	A/D	TF350L	FX350	A/D	FX350	NF350	NF350	T380	T380	
1304		83	04	EF380	EF380		TF350L	A/D	TF350L	FX350	A/D	FX350	NF350	NF350	T380	T380	
1307		84	94	EF380	EF380		TF350L	A/D	TF350L	FX350	A/D	FX350	NF350	NF350	T380	T380	
1309		90	01	EF380	EF380		TF350L	A/D	TF350L	FX350	A/D	FX350	NF350	NF350	T380	T380	
1310		83	04	EF380	EF380		TF350L	A/D	TF350L	FX350	A/D	FX350	NF350	NF350	T380	T380	
		83	04	EF380	EF380		TF350L	A/D	TF350L	FX350	A/D	FX350	NF350	NF350	T380	T380	
1410		85	98	EF380	EF380		TF350L	A/D	TF350L	FX350	A/D	FX350	NF350	NF350	T380	T380	
		85	98	EF380	EF380		TF350L	A/D	TF350L	FX350	A/D	FX350	NF350	NF350	T380	T380	
DOKKER		12		EF550	EF400	EX282	TF550L	A/D	TF400L	FX550	A/D	FX400	NF550	NF400	T550	T400	
		12		EF550	EF400	EX251	TF550L	A/D	TF400L	FX550	A/D	FX400	NF550	NF400	T550	T400	
DUSTER		10	13	EF500	EF500	EX300	TF500L	A/D	TF500L	FX500	A/D	FX500	NF500	NF500	T500	T500	
		14		EF600	EF450	EX353	TF600L	A/D	TF450L	FX600	A/D	FX450	NF600	NF450	T600	T450	
LODGY		12		EF550	EF400	EX282	TF550L	A/D	TF400L	FX550	A/D	FX400	NF550	NF400	T550	T400	
LOGAN		04	12	EF500	EF500		TF500L	A/D	TF500L	FX500	A/D	FX500	NF500	NF500	T500	T500	
		12		EF550	EF500		TF550L	A/D	TF500L	FX550	A/D	FX500	NF550	NF500	T550	T500	



		TRICO Exact Fit			TRICO Force			TRICO Flex			TRICO Neoform		TRICO	

...DACIA																
...LOGAN		07	12	EF500	EF500		TF500L	A/D	TF500L	FX500	A/D	FX500	NF500	NF500	T500	T500
		12		EF550	EF500	EX282	TF550L	A/D	TF500L	FX550	A/D	FX500	NF550	NF500	T550	T500
PICK UP		89	00	EF380	EF380		TF350L	A/D	TF350L	FX350	A/D	FX350	NF350	NF350	T380	T380
SANDERO		08	12	EF500	EF500	EX404	TF500L	A/D	TF500L	FX500	A/D	FX500	NF500	NF500	T500	T500
		13		EF550	EF500	EX282	TF550L	A/D	TF500L	FX550	A/D	FX500	NF550	NF500	T550	T500

DAEWOO																	
ESPERO		91	99	EF480	EF480		TF480L	A/D	TF480L	FX480	A/D	FX480	NF480	NF480	T480	T480	
EVANDA		02	05	EF550	EF500		TF550L	A/D	TF500L	FX550	A/D	FX500	NF550	NF500	T550	T500	
KALOS		02	04	EF550	EF400		TF550L	A/D	TF400L	FX550	A/D	FX400	NF550	NF400	T550	T400	
		02	05	EF550	EF400	EF380	TF550L	A/D	TF400L	FX550	A/D	FX400	NF550	NF400	T550	T400	T380
KORANDO		99	05	EF450	EF450	EF280	TF450L	A/D	TF450L	FX450	A/D	FX450	NF450	NF450	T450	T450	T280
LACETTI		97	04	EF550	EF480		TF550L	A/D	TF480L	FX550	A/D	FX480	NF550	NF480	T550	T480	
		04	05	EF550	EF480	EF450	TF550L	A/D	TF480L	FX550	A/D	FX480	NF550	NF480	T550	T480	T450
LANOS		97	05	EF480	EF480		TF480L	A/D	TF480L	FX480	A/D	FX480	NF480	NF480	T480	T480	
		97	05	EF480	EF480	EF480	TF480L	A/D	TF480L	FX480	A/D	FX480	NF480	NF480	T480	T480	T480
LEGANZA		97	04	EF550	EF480		TF550L	A/D	TF480L	FX550	A/D	FX480	NF550	NF480	T550	T480	
MATIZ		98	05	EF530	EF400	EF350	TF530L	A/D	TF400L	FX530	A/D	FX400	NF530	NF400	T530	T400	T350
MUSSO		99	05	EF500	EF450	EF350	TF500L	A/D	TF450L	FX500	A/D	FX450	NF500	NF450	T500	T450	T350
NEXIA		95	01	EF450	EF450		TF450L	A/D	TF450L	FX450	A/D	FX450	NF450	NF450	T450	T450	
		95	97	EF450	EF450	EF450	TF450L	A/D	TF450L	FX450	A/D	FX450	NF450	NF450	T450	T450	T450
NUBIRA		97	03	EF500	EF500	EF450	TF500L	A/D	TF500L	FX500	A/D	FX500	NF500	NF500	T500	T500	T450
		03	05	EF550	EF480		TF550L	A/D	TF480L	FX550	A/D	FX480	NF550	NF480	T550	T480	
		97	03	EF500	EF500	EF450	TF500L	A/D	TF500L	FX500	A/D	FX500	NF500	NF500	T500	T500	T450
		97	05	EF500	EF500	EF380	TF500L	A/D	TF500L	FX500	A/D	FX500	NF500	NF500	T500	T500	T380
		03	05	EF550	EF480		TF550L	A/D	TF480L	FX550	A/D	FX480	NF550	NF480	T550	T480	
REXTON		02	05	EF500	EF500	EF350	TF500L	A/D	TF500L	FX500	A/D	FX500	NF500	NF500	T500	T500	T350
REZZO		00	05	EF600	EF480	EF380	TF600L	A/D	TF480L	FX600	A/D	FX480	NF600	NF480	T600	T480	T380

DAF																
33		67	74	EF280	EF280										T280	T280
44		66	74	EF330	EF330										T330	T330
		68	74	EF330	EF330										T330	T330
55		67	72	EF330	EF330										T330	T330
		68	72	EF330	EF330										T330	T330
		68	72	EF330	EF330										T330	T330
66		72	75	EF330	EF330										T330	T330
		73	75	EF330	EF330										T330	T330
400-Serie		89	93	EF500	EF500		TF500L	A/D	TF500L	FX500	A/D	FX500	NF500	NF500	T500	T500

DAIHATSU																	
APPLAUSE		89	00	EF450*	EF450*										T450*	T450*	
BEGO		05		EF530	EF450	EX305	TF530L	A/D	TF450L	FX530	A/D	FX450	NF530	NF450	T530	T450	
CHARADE		90	93	EF450*	EF450*	EF330									T450*	T450*	T330
		93		EF480	EF450		TF480L	A/D	TF450L	FX480	A/D	FX450	NF480	NF450	T480	T450	
		77	83	EF450*	EF450*	EF330									T450*	T450*	T330
		83	87	EF450	EF450		TF450L	A/D	TF450L	FX450	A/D	FX450	NF450	NF450	T450	T450	
		87	93	EF450*	EF450*										T450*	T450*	
		93	99	EF480	EF450	EF380	TF480L	A/D	TF450L	FX480	A/D	FX450	NF480	NF450	T480	T450	T380

				TRICO Exact Fit			TRICO Force			TRICO Flex			TRICO Neoform		TRICO	
--	--	--	--	------------------------	--	--	--------------------	--	--	-------------------	--	--	----------------------	--	--------------	--

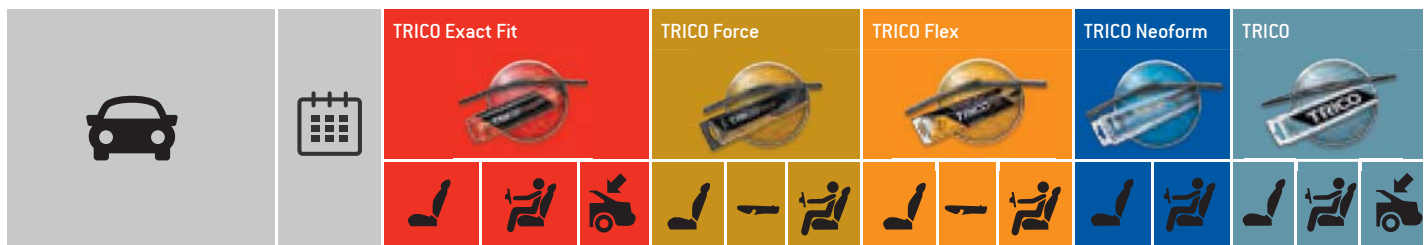

...DAIHATSU

...CHARADE	03		EF480	EF450	EF380	TF480L	A/D	TF450L	FX480	A/D	FX450	NF480	NF450	T480	T450	T380
CHARMANT	81	87	EF450*	EF450*										T450*	T450*	
COO	06		EF500	EF480	EX305	TF500L	A/D	TF480L	FX500	A/D	FX480	NF500	NF480	T500	T480	
COPEN	03		EF450	EF400		TF450L	A/D	TF400L	FX450	A/D	FX400	NF450	NF400	T450	T400	
CUORE	80	85	EF450*	EF400*										T450*	T400*	
	85	94	EF400*	EF400*	EF330									T400*	T400*	T330
	94	98	EF450	EF400		TF450L	A/D	TF400L	FX450	A/D	FX400	NF450	NF400	T450	T400	
	98	03	EF450	EF380	EF280	TF450L	A/D	TF350L	FX450	A/D	FX350	NF450	NF350	T450	T380	T280
	03	07	EF530	EF280	EF280									T530	T280	T280
	07		EF550	EF280	EX305									T550	T280	
ESSE	05		EF500	EF400	EX305	TF500L	A/D	TF400L	FX500	A/D	FX400	NF500	NF400	T500	T400	
FEROZA	88		EF430*	EF430*										T430*	T430*	
GRAN MOVE	96		EF500	EF480	EF280	TF500L	A/D	TF480L	FX500	A/D	FX480	NF500	NF480	T500	T480	T280
HIJET	86	98	EF380	EF380		TF350L	A/D	TF350L	FX350	A/D	FX350	NF350	NF350	T380	T380	
	98		EF400	EF400		TF400L	A/D	TF400L	FX400	A/D	FX400	NF400	NF400	T400	T400	
MATERIA	06		EF500	EF480	EX305	TF500L	A/D	TF480L	FX500	A/D	FX480	NF500	NF480	T500	T480	
MAX	00		EF530	EF280	EF280									T530	T280	T280
MOVE	94		EF430	EF380	EF280	TF430L	A/D	TF350L	FX430	A/D	FX350	NF430	NF350	T430	T380	T280
	02		EF530	EF280										T530	T280	
NAKED	99	05	EF530	EF280	EF280									T530	T280	T280
ROCKY	85	98	EF400*	EF400*	EF330									T400*	T400*	T330
SIRION	98	05	EF480	EF450	EF280	TF480L	A/D	TF450L	FX480	A/D	FX450	NF480	NF450	T480	T450	T280
	05		EF500	EF400	EX350	TF500L	A/D	TF400L	FX500	A/D	FX400	NF500	NF400	T500	T400	
SPARCAR	83	86	EF350	EF350		TF350L	A/D	TF350L	FX350	A/D	FX350	NF350	NF350	T350	T350	
TAFT	76	01	EF280	EF280	EF280									T280	T280	T280
TERIOS	97	05	EF500	EF350	EF280	TF500L	A/D	TF350L	FX500	A/D	FX350	NF500	NF350	T500	T350	T280
	05		EF530	EF450	EX305	TF530L	A/D	TF450L	FX530	A/D	FX450	NF530	NF450	T530	T450	
TREVIS	06		EF500	EF400	EX305	TF500L	A/D	TF400L	FX500	A/D	FX400	NF500	NF400	T500	T400	
WILDCAT/ROCKY	85	87	EF400*	EF400*	EF330									T400*	T400*	T330
YRV	01		EF530	EF350	EX305	TF530L	A/D	TF350L	FX530	A/D	FX350	NF530	NF350	T530	T350	

DAIMLER

2.8 - 5.3	69	93	EF350	EF350		TF350L	A/D	TF350L	FX350	A/D	FX350	NF350	NF350	T350	T350	
COUPE	73	77	EF350	EF350		TF350L	A/D	TF350L	FX350	A/D	FX350	NF350	NF350	T350	T350	
DAIMLER	89	03	EF530			TF530L	A/D		FX530	A/D		NF530		T530		
LIMOUSINE	68	91	EF350	EF350		TF350L	A/D	TF350L	FX350	A/D	FX350	NF350	NF350	T350	T350	
XJ	86	94	EF400	EF400		TF400L	A/D	TF400L	FX400	A/D	FX400	NF400	NF400	T400	T400	

DODGE

AVENGER	07		HF600	HF550		TF600L	A/D	TF550L	FX600	A/D	FX550	NF600	NF550			
CALIBER	06		EF600	EF430	EF280	TF600L	A/D	TF430L	FX600	A/D	FX430	NF600	NF430	T600	T430	T280
MPV	06		EF600	EF430	EF280	TF600L	A/D	TF430L	FX600	A/D	FX430	NF600	NF430	T600	T430	T280
CARAVAN	88	95	EF450	EF450	EF400	TF450L	A/D	TF450L	FX450	A/D	FX450	NF450	NF450	T450	T450	T400
	95	07	EF700	EF700	EF400	TF700L	A/D	TF700L	FX700	A/D	FX700	NF700	NF700	T700	T700	T400
CHALLENGER	07		EF550	EF550		TF550L	A/D	TF550L	FX550	A/D	FX550	NF550	NF550	T550	T550	
CHARGER	05	10	EF550	EF550		TF550L	A/D	TF550L	FX550	A/D	FX550	NF550	NF550	T550	T550	
DAKOTA	89	03	EF500	EF500		TF500L	A/D	TF500L	FX500	A/D	FX500	NF500	NF500	T500	T500	
DURANGO	03	10	EF650	EF530		TF650L	A/D	TF530L	FX650	A/D	FX530	NF650	NF530	T650	T530	



		TRICO Exact Fit			TRICO Force			TRICO Flex			TRICO Neoform		TRICO	

...DODGE

...DURANGO	10		HF550	HF500	EX305	TF550L	A/D	TF500L	FX550	A/D	FX500	NF550	NF500	T550	T500	
GRAND CARAVAN	07		EF650	EF500	EX404	TF650L	A/D	TF500L	FX650	A/D	FX500	NF650	NF500	T650	T500	
INTREPID	92	04	EF600	EF550		TF600L	A/D	TF550L	FX600	A/D	FX550	NF600	NF550	T600	T550	
JOURNEY	08		EF600	EF450		TF600L	A/D	TF450L	FX600	A/D	FX450	NF600	NF450	T600	T450	
NEON	94	99	EF530	EF450		TF530L	A/D	TF450L	FX530	A/D	FX450	NF530	NF450	T530	T450	
	99		EF550	EF480		TF550L	A/D	TF480L	FX550	A/D	FX480	NF550	NF480	T550	T480	
	94	99	EF530	EF450		TF530L	A/D	TF450L	FX530	A/D	FX450	NF530	NF450	T530	T450	
NITRO	07		EF480	EF480		TF480L	A/D	TF480L	FX480	A/D	FX480	NF480	NF480	T480	T480	
RAM	91	01	EF500	EF500		TF500L	A/D	TF500L	FX500	A/D	FX500	NF500	NF500	T500	T500	
	01	09	EF600	EF600		TF600L	A/D	TF600L	FX600	A/D	FX600	NF600	NF600	T600	T600	
	10		EF550	EF550		TF550L	A/D	TF550L	FX550	A/D	FX550	NF550	NF550	T550	T550	
RAMCHARGER	83	93	EF450	EF450	EF450	TF450L	A/D	TF450L	FX450	A/D	FX450	NF450	NF450	T450	T450	T450
STRATUS	95	01	EF550	EF550		TF550L	A/D	TF550L	FX550	A/D	FX550	NF550	NF550	T550	T550	
VIPER	91	02	EF400	EF400		TF400L	A/D	TF400L	FX400	A/D	FX400	NF400	NF400	T400	T400	
		91	02	EF400	EF400		TF400L	A/D	TF400L	FX400	A/D	FX400	NF400	NF400	T400	T400

FERRARI

208/308	75	89	EF450	EF450		TF450L	A/D	TF450L	FX450	A/D	FX450	NF450	NF450	T450	T450
365 GT 2+2	67	71	EF380	EF380		TF350L	A/D	TF350L	FX350	A/D	FX350	NF350	NF350	T380	T380
365 GTB/4 DAYTONA	69	74	EF380	EF380		TF350L	A/D	TF350L	FX350	A/D	FX350	NF350	NF350	T380	T380
365 GTS/4 DAYTONA	71	74	EF380	EF380		TF350L	A/D	TF350L	FX350	A/D	FX350	NF350	NF350	T380	T380
DINO GT	69	73	EF380	EF380		TF350L	A/D	TF350L	FX350	A/D	FX350	NF350	NF350	T380	T380
DINO GTS	72	73	EF380	EF380		TF350L	A/D	TF350L	FX350	A/D	FX350	NF350	NF350	T380	T380
MONDIAL	80	93	EF500	EF500		TF500L	A/D	TF500L	FX500	A/D	FX500	NF500	NF500	T500	T500
		84	93	EF500	EF500		TF500L	A/D	TF500L	FX500	A/D	FX500	NF500	NF500	T500
TESTAROSSA	84	91	EF500	EF500		TF500L	A/D	TF500L	FX500	A/D	FX500	NF500	NF500	T500	T500

FIAT

124	66	75	EF330	EF330										T330	T330	
		67	75	EF330	EF330										T330	T330
	67	76	EF330	EF330										T330	T330	
		66	85	EF330	EF330									T330	T330	
125	67	74	EF330	EF330										T330	T330	
126	72	00	EF330	EF330	EF280									T330	T330	T280
127	71	86	EF330	EF330	EF330									T330	T330	T330
		77	86	EF330	EF330	EF330								T330	T330	T330
128	69	84	EF330	EF330	EF450									T330	T330	T450
130	69	78	EF380	EF380		TF350L	A/D	TF350L	FX350	A/D	FX350	NF350	NF350	T380	T380	
		71	78	EF380	EF380		TF350L	A/D	TF350L	FX350	A/D	FX350	NF350	NF350	T380	T380
131	74	84	EF380	EF380		TF350L	A/D	TF350L	FX350	A/D	FX350	NF350	NF350	T380	T380	
		75	85	EF380	EF380		TF350L	A/D	TF350L	FX350	A/D	FX350	NF350	NF350	T380	T380
132	72	82	EF380	EF380		TF350L	A/D	TF350L	FX350	A/D	FX350	NF350	NF350	T380	T380	
135 DINO	72	74	EF330	EF330										T330	T330	
		67	72	EF330	EF330									T330	T330	
147	76	96	EF400			TF400L	A/D		FX400	A/D		NF400		T400		
		80	95	EF400			TF400L	A/D		FX400	A/D		NF400		T400	
238-SERIE	66	82	EF380	EF380		TF350L	A/D	TF350L	FX350	A/D	FX350	NF350	NF350	T380	T380	
242-SERIE	75	82	EF380	EF380		TF350L	A/D	TF350L	FX350	A/D	FX350	NF350	NF350	T380	T380	

			TRICO Exact Fit			TRICO Force			TRICO Flex			TRICO Neoform		TRICO	
--	--	--	------------------------	--	--	--------------------	--	--	-------------------	--	--	----------------------	--	--------------	--

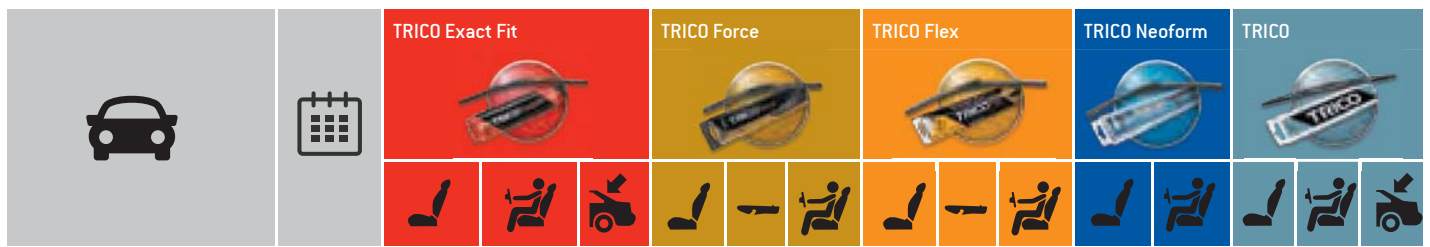

...FIAT

500		07		EFB6018L	EFB3518L	EX282	TF600L	BC	TF350L	FX600	BC	FX350	NF609	NF359			
		60	66	EF280	EF280											T280	T280
		09		EFB6018L	EFB3518L		TF600L	BC	TF350L	FX600	BC	FX350	NF609	NF359			
Special Design		57	76	EF280	EF280											T280	T280
500 L		12		EFB6018L	EFB3518L	EX282	TF600L	BC	TF350L	FX600	BC	FX350	NF609	NF359			
500 L Living		12		EFB6018L	EFB3518L		TF600L	BC	TF350L	FX600	BC	FX350	NF609	NF359			
500 X		14		EFB6518L	EFB3518L	EX282	TF650L	BC	TF350L	FX650	BC	FX350	NF659	NF359			
600		55	71	EF330	EF330											T330	T330
850		64	72	EF330	EF330											T330	T330
		68	72	EF330	EF330											T330	T330
		65	72	EF330	EF330											T330	T330
ARGENTA		78	86	EF380	EF380		TF350L	A/D	TF350L	FX350	A/D	FX350	NF350	NF350	T380	T380	
BARCHETTA		95	05	EF480	EF480		TF480L	A/D	TF480L	FX480	A/D	FX480	NF480	NF480	T480	T480	
BRAVA		95	02	EF580	EF480		TF550L	A/D	TF480L	FX550	A/D	FX480	NF550	NF480	T580	T480	
BRAVO		95	02	EF580	EF480		TF550L	A/D	TF480L	FX550	A/D	FX480	NF550	NF480	T580	T480	
		06		EFB6018L	EFB4318L	EX282	TF600L	BC	TF430L	FX600	BC	FX430	NF609	NF439			
CINQUECENTO		91	99	EF480	EF480	EF280	TF480L	A/D	TF480L	FX480	A/D	FX480	NF480	NF480	T480	T480	T280
COUPE		93	00	EF530	EF480		TF530L	A/D	TF480L	FX530	A/D	FX480	NF530	NF480	T530	T480	
CROMA		85	96	EF500	EF500	EF450	TF500L	A/D	TF500L	FX500	A/D	FX500	NF500	NF500	T500	T500	T450
		05		EFB606	EFB436		TF600L	BC	TF430L	FX600	BC+E	FX430	NF606	NF436			
DOBLO	MPV	01	08	EF550	EF450		TF550L	A/D	TF450L	FX550	A/D	FX450	NF550	NF450	T550	T450	
		09		EFB6018L	EFB4018L	EX358	TF600L	BC	TF400L	FX600	BC	FX400	NF609	NF409			
DOBLO Van		01	09	EF550	EF450		TF550L	A/D	TF450L	FX550	A/D	FX450	NF550	NF450	T550	T450	
		10		EFB6018L	EFB4018L		TF600L	BC	TF400L	FX600	BC	FX400	NF609	NF409			
DUCATO Van		94	06	EF550	EF550		TF550L	A/D	TF550L	FX550	A/D	FX550	NF550	NF550	T550	T550	
		06		EFB6518L	EFB5318L		TF650L	BC	TF550L	FX650	BC	FX550	NF659	NF539			
DUNA		87	91	EF450	EF450	EF450	TF450L	A/D	TF450L	FX450	A/D	FX450	NF450	NF450	T450	T450	T450
		87	91	EF450	EF450	EF450	TF450L	A/D	TF450L	FX450	A/D	FX450	NF450	NF450	T450	T450	T450
FIORINO Van		77	87	EF330	EF330											T330	T330
		78	88	EF400			TF400L	A/D		FX400	A/D		NF400			T400	
		80	93	EF450			TF450L	A/D		FX450	A/D		NF450			T450	
		07		EFB6514L	EFB4014L		TF650L	F	TF450L	FX650	E1		NF6514	NF4014			
FREEMONT		11		EF600	EF480	EX305	TF600L	A/D	TF480L	FX600	A/D	FX480	NF600	NF480	T600	T480	
GRANDE PUNTO		08		EFB6517L	EFB4017L	EX300	TF650L	BC	TF400L	FX650	BC	FX400	NF657	NF407			
IDEA		03		EF580	EF400		TF550L	A/D	TF400L	FX550	A/D	FX400	NF550	NF400	T580	T400	
LINEA		07		EFB606	EFB436		TF600L	BC	TF430L	FX600	BC+E	FX430	NF606	NF436			
MAREA		96	07	EF580	EF480		TF550L	A/D	TF480L	FX550	A/D	FX480	NF550	NF480	T580	T480	
		96	07	EF580	EF480		TF550L	A/D	TF480L	FX550	A/D	FX480	NF550	NF480	T580	T480	
MULTIPLA		99	05	EF600	EF550		TF600L	A/D	TF550L	FX600	A/D	FX550	NF600	NF550	T600	T550	
		06	12	EFB6017L	EFB5517L		TF600L	BC	TF550L	FX600	BC	FX550	NF607	NF557			
PALIO		96		EF580	EF450		TF550L	A/D	TF450L	FX550	A/D	FX450	NF550	NF450	T580	T450	
		96		EF580	EF450		TF550L	A/D	TF450L	FX550	A/D	FX450	NF550	NF450	T580	T450	
PANDA		80	04	EF400		EF330	TF400L	A/D		FX400	A/D		NF400			T400	T330
		03	11	EF580	EF400		TF550L	A/D	TF400L	FX550	A/D	FX400	NF550	NF400	T580	T400	
		12		EFB6018L	EFB3518L	EX282	TF600L	BC	TF350L	FX600	BC	FX350	NF609	NF359			
PUNTO / GRANDE PUNTO		05		EFB6517L	EFB4017L	EX300	TF650L	BC	TF400L	FX650	BC	FX400	NF657	NF407			





...FIAT

PUNTO		93	99	EF580	EF400		TF550L	A/D	TF400L	FX550	A/D	FX400	NF550	NF400	T550	T400	
		99	07	EF550	EF450		TF550L	A/D	TF450L	FX550	A/D	FX450	NF550	NF450	T550	T450	
		12		EFB6517L	EFB4017L	EX300	TF650L	BC	TF400L	FX650	BC	FX400	NF657	NF407			
		94	00	EF580	EF400		TF550L	A/D	TF400L	FX550	A/D	FX400	NF550	NF400	T580	T400	
PUNTO EVO		08	12	EFB6517L	EFB4017L	EX300	TF650L	BC	TF400L	FX650	BC	FX400	NF657	NF407			
PUNTO Van		96	00	EF580	EF400		TF550L	A/D	TF400L	FX550	A/D	FX400	NF550	NF400	T580	T400	
		00	09	EF550	EF450		TF550L	A/D	TF450L	FX550	A/D	FX450	NF550	NF450	T550	T450	
		09		EFB6517L	EFB4017L		TF650L	BC	TF400L	FX650	BC	FX400	NF657	NF407			
QUBO		08		EFB6514L	EFB4514L		TF650L	F	TF450L	FX650	E1	FX450	NF6514	NF4514			
REGATA		83	90	EF400	EF400	EF380	TF400L	A/D	TF400L	FX400	A/D	FX400	NF400	NF400	T400	T400	T380
		83	90	EF400	EF400	EF380	TF400L	A/D	TF400L	FX400	A/D	FX400	NF400	NF400	T400	T400	T380
RITMO		78	88	EF400	EF400	EF380	TF400L	A/D	TF400L	FX400	A/D	FX400	NF400	NF400	T400	T400	T380
		79	89	EF400	EF400		TF400L	A/D	TF400L	FX400	A/D	FX400	NF400	NF400	T400	T400	
SCUDO		96	06	EF650	EF500	EF400							NF650	NF500			
	MPV	07		EF700	EF500	EX404	TF700L	A/D	TF500L	FX700	A/D	FX500	NF700	NF500	T700	T500	
SCUDO Van		07		EF700	EF500		TF700L	A/D	TF500L	FX700	A/D	FX500	NF700	NF500	T700	T500	
SEDICI		06		EF650	EF350		TF650L	A/D	TF350L	FX650	A/D	FX350	NF650	NF350	T650	T350	
SEICENTO		98	10	EF480	EF480		TF480L	A/D	TF480L	FX480	A/D	FX480	NF480	NF480	T480	T480	
Van		98	10	EF480	EF480		TF480L	A/D	TF480L	FX480	A/D	FX480	NF480	NF480	T480	T480	
SIENA		96		EF580	EF450		TF550L	A/D	TF450L	FX550	A/D	FX450	NF550	NF450	T580	T450	
STILO		01	05	EF530	EF480		TF530L	A/D	TF480L	FX530	A/D	FX480	NF530	NF480	T530	T480	
		03	05	EF530	EF480	EX353	TF530L	A/D	TF480L	FX530	A/D	FX480	NF530	NF480	T530	T480	
		06	08	EFB5517L	EFB4817L	EX353	TF550L	BC	TF480L	FX550	BC	FX480	NF557	NF487			
STRADA		98		EF600	EF400		TF600L	A/D	TF400L	FX600	A/D	FX400	NF600	NF400	T600	T400	
TALENTO		89	94	EF500	EF500	EF380	TF500L	A/D	TF500L	FX500	A/D	FX500	NF500	NF500	T500	T500	T380
TIPO		87	96	EF480	EF480	EF400	TF480L	A/D	TF480L	FX480	A/D	FX480	NF480	NF480	T480	T480	T400
ULYSSE		94	02	EF650	EF500	EF400	TF650L	A/D	TF500L	FX650	A/D	FX500	NF650	NF500	T650	T500	T400
		02	06	EF653	EF653	EX353											
		06	11	EF650	EF650	EX353	TF650L	A/D	TF650R	FX650	A/D	FX650	NF650	NF650	T650	T650	
UNO		83	06	EF450		EF330	TF450L	A/D		FX450	A/D		NF450		T450		T330
X 1/9		73	89	EF380	EF380		TF350L	A/D	TF350L	FX350	A/D	FX350	NF350	NF350	T380	T380	

FORD

B-MAX		12		EFB7317L	EFB6517R	EX300	TF730L	BC	TF650R	FX730	BC	FX650	NF739	NF657			
CAPRI		78	87	EF380	EF380		TF350L	A/D	TF350L	FX350	A/D	FX350	NF350	NF350	T380	T380	
C-MAX		07	10	EFB656	EFB486	EX281	TF650L	BC	TF480L	FX650	BC+E	FX480	NF656	NF486			
		10		EFB7317L	EFB6517R	EX300	TF730L	BC	TF650R	FX730	BC	FX650	NF739	NF657			
CONSUL		72	75	EF450	EF450	EF380	TF450L	A/D	TF450L	FX450	A/D	FX450	NF450	NF450	T450	T450	T380
		72	75	EF450	EF450	EF380	TF450L	A/D	TF450L	FX450	A/D	FX450	NF450	NF450	T450	T450	T380
		72	75	EF450	EF450		TF450L	A/D	TF450L	FX450	A/D	FX450	NF450	NF450	T450	T450	
CORTINA		79	82	EF400*	EF400*										T400*	T400*	
COUGAR		98	01	EF550	EF500		TF550L	A/D	TF500L	FX550	A/D	FX500	NF550	NF500	T550	T500	
COURIER		98	02	EF480	EF480		TF480L	A/D	TF480L	FX480	A/D	FX480	NF480	NF480	T480	T480	
ECONOVAN		85	92	EF400	EF400		TF400L	A/D	TF400L	FX400	A/D	FX400	NF400	NF400	T400	T400	
ECOSPORT		13				EF280											T280
ESCORT		68	76	EF350	EF350		TF350L	A/D	TF350L	FX350	A/D	FX350	NF350	NF350	T350	T350	
		73	80	EF350	EF350	EF350	TF350L	A/D	TF350L	FX350	A/D	FX350	NF350	NF350	T350	T350	T350



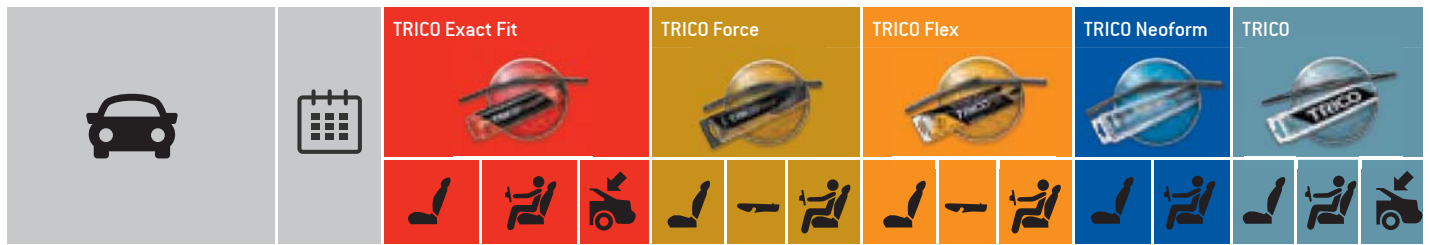

...FORD

...ESCORT	93	99	EF500	EF500		TF500L	A/D	TF500L	FX500	A/D	FX500	NF500	NF500	T500	T500		
	80	85	EF450	EF450	EF450	TF450L	A/D	TF450L	FX450	A/D	FX450	NF450	NF450	T450	T450	T450	
	85	90	EF450	EF450	EF450	TF450L	A/D	TF450L	FX450	A/D	FX450	NF450	NF450	T450	T450	T450	
	90	02	EF500	EF500	EF500							NF500	NF500				
	75	81	EF350	EF350	EF330	TF350L	A/D	TF350L	FX350	A/D	FX350	NF350	NF350	T350	T350	T330	
	80	90	EF450	EF450	EF380	TF450L	A/D	TF450L	FX450	A/D	FX450	NF450	NF450	T450	T450	T380	
	90	00	EF500	EF500	EF380							NF500	NF500			T380	
	83	90	EF450	EF450		TF450L	A/D	TF450L	FX450	A/D	FX450	NF450	NF450	T450	T450		
	90	00	EF500	EF500		TF500L	A/D	TF500L	FX500	A/D	FX500	NF500	NF500	T500	T500		
ESCORT Van	81	90	EF450	EF450		TF450L	A/D	TF450L	FX450	A/D	FX450	NF450	NF450	T450	T450		
	90	01	EF500	EF500		TF500L	A/D	TF500L	FX500	A/D	FX500	NF500	NF500	T500	T500		
FIESTA		83	89	EF400	EF400	EF400	TF400L	A/D	TF400L	FX400	A/D	FX400	NF400	NF400	T400	T400	T400
		89	02	EF480	EF480	EF400	TF480L	A/D	TF480L	FX480	A/D	FX480	NF480	NF480	T480	T480	T400
		01	08	EF550	EF400	EX281	TF550L	A/D	TF400L	FX550	A/D	FX400	NF550	NF400	T550	T400	
		08		EFB6518L	EFB4018L	EX308	TF650L	BC	TF400L	FX650	BC	FX400	NF659	NF409			
FIESTA Van		77	95	EF400	EF400		TF400L	A/D	TF400L	FX400	A/D	FX400	NF400	NF400	T400	T400	
		91	02	EF480	EF480		TF480L	A/D	TF480L	FX480	A/D	FX480	NF480	NF480	T480	T480	
		03	08	EF550	EF400		TF550L	A/D	TF400L	FX550	A/D	FX400	NF550	NF400	T550	T400	
		09		EFB6518L	EFB4018L	EX308	TF650L	BC	TF400L	FX650	BC	FX400	NF659	NF409			
FOCUS		99	05	EF550	EF480		TF550L	A/D	TF480L	FX550	A/D	FX480	NF550	NF480	T550	T480	
		05	10	EFB656	EFB436		TF650L	BC	TF430L	FX650	BC+E	FX430	NF656	NF436			
		11		EFB7318L	EFB7318R					FX730	BC	FX730	NF739	NF739			
		99	05	EF550	EF480	EF380	TF550L	A/D	TF480L	FX550	A/D	FX480	NF550	NF480	T550	T480	T380
		04	05	EFB656	EFB436	EX355	TF650L	BC	TF430L	FX650	BC+E	FX430	NF656	NF436			T350
		06	10	EFB656	EFB436	EX357	TF650L	BC	TF430L	FX650	BC+E	FX430	NF656	NF436			
		11		EFB7318L	EFB7318R	EX308				FX730	BC	FX730	NF739	NF739			
		99	05	EF550	EF480	EX281	TF550L	A/D	TF480L	FX550	A/D	FX480	NF550	NF480	T550	T480	T280
		04	10	EFB656	EFB436	EX281	TF650L	A/D	TF430L	FX650	A/D	FX430	NF656	NF436			
		11		EFB7318L	EFB7318R	EX308				FX730	BC	FX730	NF739	NF739			
		06	10	EFB656	EFB436		TF650L	BC	TF430L	FX650	BC+E	FX430	NF656	NF436			
FOCUS C-MAX		03	07	EFB656	EFB486	EF280	TF650L	BC	TF480L	FX650	BC+E	FX480	NF656	NF486			T280
FUSION		02	08	EF550	EF400	EX281	TF550L	A/D	TF400L	FX550	A/D	FX400	NF550	NF400	T550	T400	T280
GALAXY		95	00	EF701	EF701	EF400											T400
		01	06	EFB706	EFB706	EF400	TF700L	BC	TF700R	FX700	BC+E	FX700	NF706	NF706			T400
		06	08	EFB7518L	EFB6518R		TF750L	BC		FX750	BC	FX650	NF759	NF659			
		09		EFB7518L	EFB6518R	EX308	TF750L	BC		FX750	BC	FX650	NF759	NF659			
GRANADA		72	85	EF450	EF450		TF450L	A/D	TF450L	FX450	A/D	FX450	NF450	NF450	T450	T450	
		72	77	EF450	EF450		TF450L	A/D	TF450L	FX450	A/D	FX450	NF450	NF450	T450	T450	
		77	85	EF450	EF450	EF500	TF450L	A/D	TF450L	FX450	A/D	FX450	NF450	NF450	T450	T450	T500
		72	76	EF450	EF450		TF450L	A/D	TF450L	FX450	A/D	FX450	NF450	NF450	T450	T450	
GRAND C-MAX		10		EFB7317L	EFB6517R	EX300	TF730L	BC	TF650R	FX730	BC	FX650	NF759	NF657			
KA		96	08	EF480	EF430	EX355	TF480L	A/D	TF430L	FX480	A/D	FX430	NF480	NF430	T480	T430	T350
		08	10	EF600	EF350	EX282	TF600L	A/D	TF350L	FX600	A/D	FX350	NF600	NF350	T600	T350	
		11		EFB6018L	EFB3518L	EX282	TF600L	BC	TF350L	FX600	BC	FX350	NF609	NF359			
KUGA		08	13	EFB6018L	EFB4318L	EX308	TF600L	BC	TF430L	FX600	BC	FX430	NF609	NF439			T350
		13		EFB7017L	EFB7017R	EX304	TF700L	BC	TF700R	FX700	BC	FX700	NF707	NF707			





...FORD				TRICO Exact Fit			TRICO Force			TRICO Flex			TRICO Neoform		TRICO		
MAVERICK	SUV	93	98	EF530	EF500	EF280	TF530L	A/D	TF500L	FX530	A/D	FX500	NF530	NF500	T530	T500	T280
		01	07	EF480	EF480	EF280	TF480L	A/D	TF480L	FX480	A/D	FX480	NF480	NF480	T480	T480	T280
		96	98	EF530	EF500		TF530L	A/D	TF500L	FX530	A/D	FX500	NF530	NF500	T530	T500	
MONDEO		93	00	EF530	EF500		TF530L	A/D	TF500L	FX530	A/D	FX500	NF530	NF500	T530	T500	
		00	07	EF550	EF500		TF550L	A/D	TF500L	FX550	A/D	FX500	NF550	NF500	T550	T500	
		07	14	EFB6518L	EFB4818L		TF650L	BC	TF480L	FX650	BC	FX480	NF659	NF489			
		15		EFB7017L	EFB7017L		TF700L	BC	TF700L	FX700	BC	FX700	NF707	NF707			
		93	00	EF530	EF500	EF550	TF530L	A/D	TF500L	FX530	A/D	FX500	NF530	NF500	T530	T500	T550
		00	07	EF550	EF500	EF480	TF550L	A/D	TF500L	FX550	A/D	FX500	NF550	NF500	T550	T500	T480
		07	14	EFB6518L	EFB4818L	NF489	TF650L	BC	TF480L	FX650	BC	FX480	NF659	NF489			
		15		EFB7017L	EFB7017L	EFB5017L	TF700L	BC	TF700L	FX700	BC	FX700	NF707	NF707			
		93	00	EF530	EF500	EF330	TF530L	A/D	TF500L	FX530	A/D	FX500	NF530	NF500	T530	T500	T330
		00	07	EF550	EF500	EX281	TF550L	A/D	TF500L	FX550	A/D	FX500	NF550	NF500	T550	T500	
		07	14	EFB6518L	EFB4818L	EX308	TF650L	BC	TF480L	FX650	BC	FX480	NF659	NF489			
		15		EFB7017L	EFB7017L	EX253	TF700L	BC	TF700L	FX700	BC	FX700	NF707	NF707			
ORION		83	90	EF450	EF450		TF450L	A/D	TF450L	FX450	A/D	FX450	NF450	NF450	T450	T450	
		90	94	EF500	EF500		TF500L	A/D	TF500L	FX500	A/D	FX500	NF500	NF500	T500	T500	
P 100		82	87	EF450	EF450		TF450L	A/D	TF450L	FX450	A/D	FX450	NF450	NF450	T450	T450	
		87	92	EF500	EF500		TF500L	A/D	TF500L	FX500	A/D	FX500	NF500	NF500	T500	T500	
PUMA		97	02	EF480	EF480		TF480L	A/D	TF480L	FX480	A/D	FX480	NF480	NF480	T480	T480	
RANGER		98	10	EF450	EF450		TF450L	A/D	TF450L	FX450	A/D	FX450	NF450	NF450	T450	T450	
		11		EF600	EF400		TF600L	A/D	TF400L	FX600	A/D	FX400	NF600	NF400	T600	T400	
SCORPIO		86	98	EF500	EF500		TF500L	A/D	TF500L	FX500	A/D	FX500	NF500	NF500	T500	T500	
		85	94	EF500	EF500	EF500	TF500L	A/D	TF500L	FX500	A/D	FX500	NF500	NF500	T500	T500	T500
		88	98	EF500	EF500		TF500L	A/D	TF500L	FX500	A/D	FX500	NF500	NF500	T500	T500	
SIERRA		87	93	EF500	EF500		TF500L	A/D	TF500L	FX500	A/D	FX500	NF500	NF500	T500	T500	
		82	87	EF500	EF500	EF500	TF500L	A/D	TF500L	FX500	A/D	FX500	NF500	NF500	T500	T500	T500
		87	93	EF500	EF500	EF500	TF500L	A/D	TF500L	FX500	A/D	FX500	NF500	NF500	T500	T500	T500
		82	86	EF500	EF500	EF330	TF500L	A/D	TF500L	FX500	A/D	FX500	NF500	NF500	T500	T500	T330
		87	93	EF500	EF500	EF330	TF500L	A/D	TF500L	FX500	A/D	FX500	NF500	NF500	T500	T500	T330
S-MAX		06	08	EFB7518L	EFB6518R		TF750L	BC		FX750	BC	FX650	NF759	NF659			
		09	15	EFB7518L	EFB6518R	EX308	TF750L	BC		FX750	BC	FX650	NF759	NF659			
		15		EFB7518L	EFB7318R		TF750L	BC		FX750	BC	FX730	NF759	NF739			
STREET KA		03	05	EF480	EF430		TF480L	A/D	TF430L	FX480	A/D	FX430	NF480	NF430	T480	T430	
TAUNUS		70	76	EF380	EF380		TF350L	A/D	TF350L	FX350	A/D	FX350	NF350	NF350	T380	T380	
		75	79	EF380*	EF380*										T380*	T380*	
		79	82	EF450	EF450		TF450L	A/D	TF450L	FX450	A/D	FX450	NF450	NF450	T450	T450	
		70	76	EF380	EF380		TF350L	A/D	TF350L	FX350	A/D	FX350	NF350	NF350	T380	T380	
		75	79	EF400*	EF400*	EF330									T400*	T400*	T330
		79	82	EF450	EF450	EF330	TF450L	A/D	TF450L	FX450	A/D	FX450	NF450	NF450	T450	T450	T330
TOURNEO CONNECT		02	13	EF550	EF500	EX353	TF550L	A/D	TF500L	FX550	A/D	FX500	NF550	NF500	T550	T500	
		14		EFB7017L	EFB7017R		TF750L	BC	TF700R	FX750	BC	FX700	NF759	NF707			
		13		EFB7518L	EFB7018R					FX750	BC	FX700	NF759	NF709			
TRANSIT		78	00	EF550	EF550		TF550L	A/D	TF550L	FX550	A/D	FX550	NF550	NF550	T550	T550	
		00	06	EF700	EF600		TF700L	A/D	TF600L	FX700	A/D	FX600	NF700	NF600	T700	T600	
		06	12	EF650	EF550		TF650L	A/D	TF550L	FX650	A/D	FX550	NF650	NF550	T650	T550	













...FORD

...TRANSIT	13		EFB7518L	EFB5318L		TF750L	BC	TF530L	FX750	BC	FX530	NF759	NF539			
TRANSIT CONNECT	02	13	EF550	EF500	EX353	TF550L	A/D	TF500L	FX550	A/D	FX500	NF550	NF500	T550	T500	
		14	EFB7017L	EFB7017R		TF750L	BC	TF700R	FX750	BC	FX700	NF759	NF707			
TRANSIT COURIER	14		EFB7017L	EFB4017L		TF700L	BC	TF400L	FX700	BC	FX400	NF707	NF407			
TRANSIT CUSTOM	13		EFB7518L	EFB7018R					FX750	BC	FX700	NF759	NF709			
TRANSIT TOURNEO	94	00	EF550	EF550		TF550L	A/D	TF550L	FX550	A/D	FX550	NF550	NF550	T550	T550	
		06	EF650	EF550		TF650L	A/D	TF550L	FX650	A/D	FX550	NF650	NF550	T650	T550	
		13	EFB7518L	EFB5318L		TF750L	BC	TF530L	FX750	BC	FX530	NF759	NF539			

FORD USA

AEROSTAR	86	97	EF550	EF550		TF550L	A/D	TF550L	FX550	A/D	FX550	NF550	NF550	T550	T550	
BRONCO	88	90	EF450	EF450		TF450L	A/D	TF450L	FX450	A/D	FX450	NF450	NF450	T450	T450	
CONTOUR	93	00	EF530	EF500		TF530L	A/D	TF500L	FX530	A/D	FX500	NF530	NF500	T530	T500	
CROWN VICTORIA	91	05	EF550	EF550		TF550L	A/D	TF550L	FX550	A/D	FX550	NF550	NF550	T550	T550	
ECONOLINE	75	92	EF450	EF450		TF450L	A/D	TF450L	FX450	A/D	FX450	NF450	NF450	T450	T450	
		93	EF550	EF550		TF550L	A/D	TF550L	FX550	A/D	FX550	NF550	NF550	T550	T550	
ESCAPE	01	07	EF480	EF450	EF280	TF480L	A/D	TF480L	FX480	A/D	FX480	NF480	NF480	T480	T450	T280
		01	EF500	EF480		TF500L	A/D	TF480L	FX500	A/D	FX480	NF500	NF480	T500	T480	
E SERIES	93		EF500	EF500		TF500L	A/D	TF500L	FX500	A/D	FX500	NF500	NF500	T500	T500	
EXCURSION	99	05	EF500	EF500	EF400	TF500L	A/D	TF500L	FX500	A/D	FX500	NF500	NF500	T500	T500	T400
EXPEDITION	96		EF500	EF500	EF430	TF500L	A/D	TF500L	FX500	A/D	FX500	NF500	NF500	T500	T500	T430
EXPLORER	93		EF450	EF450	EF330	TF450L	A/D	TF450L	FX450	A/D	FX450	NF450	NF450	T450	T450	T330
		02	EF550	EF550	EF400	TF550L	A/D	TF550L	FX550	A/D	FX550	NF550	NF550	T550	T550	T400
F150	86	07	EF500	EF500		TF500L	A/D	TF500L	FX500	A/D	FX500	NF500	NF500	T500	T500	
F250	82	09	EF500	EF500		TF500L	A/D	TF500L	FX500	A/D	FX500	NF500	NF500	T500	T500	
F350	88	07	EF500	EF500		TF500L	A/D	TF500L	FX500	A/D	FX500	NF500	NF500	T500	T500	
FIVE HUNDRED	04		EFB606	EFB506		TF600L	A/D	TF500L	FX600	A/D	FX500	NF606	NF506			
FREESTAR	03	07	EF600	EF500	EF400	TF600L	A/D	TF500L	FX600	A/D	FX500	NF600	NF500	T600	T500	T400
FUSION	05	09	EF600	EF480		TF600L	A/D	TF480L	FX600	A/D	FX480	NF600	NF480	T600	T480	
MUSTANG		93	EF500	EF500		TF500L	A/D	TF500L	FX500	A/D	FX500	NF500	NF500	T500	T500	
		93	EF500	EF500		TF500L	A/D	TF500L	FX500	A/D	FX500	NF500	NF500	T500	T500	
PROBE	88	93	EF480	EF480		TF480L	A/D	TF480L	FX480	A/D	FX480	NF480	NF480	T480	T480	
		93	EF500	EF500		TF500L	A/D	TF500L	FX500	A/D	FX500	NF500	NF500	T500	T500	
RANGER	90	98	EF450	EF450		TF450L	A/D	TF450L	FX450	A/D	FX450	NF450	NF450	T450	T450	
TAURUS		91	EF600	EF500		TF600L	A/D	TF500L	FX600	A/D	FX500	NF600	NF500	T600	T500	
		96	EF600	EF500		TF600L	A/D	TF500L	FX600	A/D	FX500	NF600	NF500	T600	T500	
		88	EF500	EF500	EF380	TF500L	A/D	TF500L	FX500	A/D	FX500	NF500	NF500	T500	T500	T380
		96	EF600	EF500	EF380	TF600L	A/D	TF500L	FX600	A/D	FX500	NF600	NF500	T600	T500	T380
TEMPO	86	87	EF480	EF480		TF480L	A/D	TF480L	FX480	A/D	FX480	NF480	NF480	T480	T480	
THUNDERBIRD		93	EF600	EF550		TF600L	A/D	TF550L	FX600	A/D	FX550	NF600	NF550	T600	T550	
		00	EF600	EF550		TF600L	A/D	TF550L	FX600	A/D	FX550	NF600	NF550	T600	T550	
WINDSTAR	95		EF600	EF500	EF400	TF600L	A/D	TF500L	FX600	A/D	FX500	NF600	NF500	T600	T500	T400

F50

125P		67	92	EF330	EF330									T330	T330	
		67	92	EF330	EF330									T330	T330	
126P		72	00	EF330	EF330									T330	T330	
127P		69	76	EF330	EF330									T330	T330	



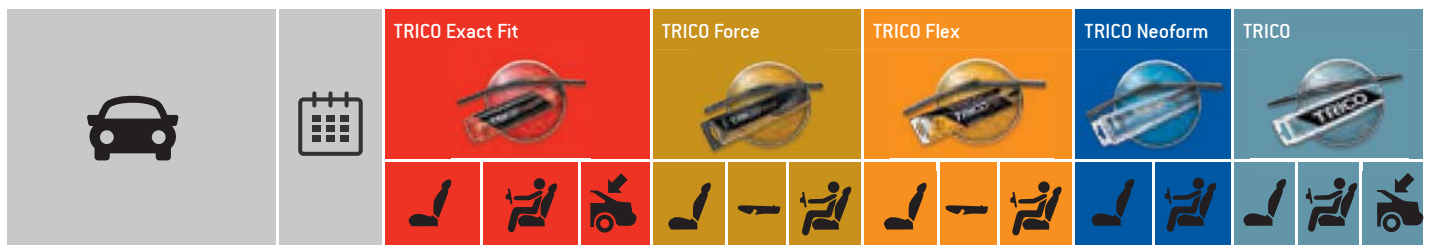

...FSO

132P		74	78	EF330	EF330									T330	T330		
POLONEZ		92	02	EF400	EF400		TF400L	A/D	TF400L	FX400	A/D	FX400	NF400	NF400	T400	T400	
		77	92	EF400	EF400		TF400L	A/D	TF400L	FX400	A/D	FX400	NF400	NF400	T400	T400	
		92	05	EF400	EF400	EF400	TF400L	A/D	TF400L	FX400	A/D	FX400	NF400	NF400	T400	T400	T400

GEELY

CK		05		EF530	EF450		TF530L	A/D	TF450L	FX530	A/D	FX450	NF530	NF450	T530	T450
HQ		05		EF450	EF450		TF450L	A/D	TF450L	FX450	A/D	FX450	NF450	NF450	T450	T450
		05		EF450	EF450		TF450L	A/D	TF450L	FX450	A/D	FX450	NF450	NF450	T450	T450
MR		05		EF550			TF550L	A/D		FX550	A/D		NF550		T550	
		05		EF550			TF550L	A/D		FX550	A/D		NF550		T550	

GEO

METRO		89	98	EF500	EF480		TF500L	A/D	TF480L	FX500	A/D	FX480	NF500	NF480	T500	T480
		89	98	EF500	EF480		TF500L	A/D	TF480L	FX500	A/D	FX480	NF500	NF480	T500	T480
		89	98	EF500	EF480		TF500L	A/D	TF480L	FX500	A/D	FX480	NF500	NF480	T500	T480

GMC

G SERIE		75	84	EF400	EF400		TF400L	A/D	TF400L	FX400	A/D	FX400	NF400	NF400	T400	T400	
JIMMY		89	98	EF400	EF400	EF400	TF400L	A/D	TF400L	FX400	A/D	FX400	NF400	NF400	T400	T400	T400
SAFARI		93	04	EF450	EF450		TF450L	A/D	TF450L	FX450	A/D	FX450	NF450	NF450	T450	T450	
SIERRA		96	07	EF450	EF450		TF450L	A/D	TF450L	FX450	A/D	FX450	NF450	NF450	T450	T450	
SUBURBAN		86	99	EF450	EF450	EF350	TF450L	A/D	TF450L	FX450	A/D	FX450	NF450	NF450	T450	T450	T350
YUKON		91	00	EF400	EF400	EF350	TF400L	A/D	TF400L	FX400	A/D	FX400	NF400	NF400	T400	T400	T350
		91	00	EF450	EF450		TF450L	A/D	TF450L	FX450	A/D	FX450	NF450	NF450	T450	T450	

HONDA

ACCORD		78	85	EF430*	EF430*										T430*	T430*	
		85	89	EF450	EF450		TF450L	A/D	TF450L	FX450	A/D	FX450	NF450	NF450	T450	T450	
		90	93	EF550	EF480		TF550L	A/D	TF480L	FX550	A/D	FX480	NF550	NF480	T550	T480	
		93	97	EF550	EF500		TF550L	A/D	TF500L	FX550	A/D	FX500	NF550	NF500	T550	T500	
		03	07	EF650	EF380		TF650L	A/D	TF350L	FX650	A/D	FX350	NF650	NF350	T650	T380	
		08		HF600	HF550		TF600L	A/D	TF500L	FX600	A/D	FX500	NF600	NF550			
		79	85	EF430*	EF430*										T430*	T430*	
		99	02	EF550	EF480	EX404	TF550L	A/D	TF480L	FX550	A/D	FX480	NF550	NF480	T550	T480	
		85	89	EF450	EF450	EF380	TF450L	A/D	TF450L	FX450	A/D	FX450	NF450	NF450	T450	T450	T380
		91	93	EF550	EF480	EF380	TF550L	A/D	TF480L	FX550	A/D	FX480	NF550	NF480	T550	T480	T380
		93	98	EF550	EF500		TF550L	A/D	TF500L	FX550	A/D	FX500	NF550	NF500	T550	T500	
		03	07	EF650	EF380	EX306	TF650L	A/D	TF350L	FX650	A/D	FX350	NF650	NF350	T650	T380	
		08		HF600	HF550	EX306	TF600L	A/D	TF500L	FX600	A/D	FX500	NF600	NF550			
		92	93	EF550	EF480		TF550L	A/D	TF480L	FX550	A/D	FX480	NF550	NF480	T550	T480	
		93	98	EF550	EF500		TF550L	A/D	TF500L	FX550	A/D	FX500	NF550	NF500	T550	T500	
		03	07	EF650	EF450		TF650L	A/D	TF450L	FX650	A/D	FX450	NF650	NF450	T650	T450	
ACTY TN		79	86	EF330	EF330										T330	T330	
CIVIC		79	87	EF430	EF430	EF380	TF430L	A/D	TF430L	FX430	A/D	FX430	NF430	NF430	T430	T430	T380
		87	90	EF480	EF450		TF480L	A/D	TF450L	FX480	A/D	FX450	NF480	NF450	T480	T450	
		91	01	EF500	EF450		TF500L	A/D	TF450L	FX500	A/D	FX450	NF500	NF450	T500	T450	
		00	05	EF600	EF380		TF600L	A/D	TF350L	FX600	A/D	FX350	NF600	NF350	T600	T380	
		12		HF650	HF450		TF650L	A/D	TF450L	FX650	A/D	FX450	NF650	NF450		T450	
		72	83	EF380	EF380		TF350L	A/D	TF350L	FX350	A/D	FX350	NF350	NF350	T380	T380	



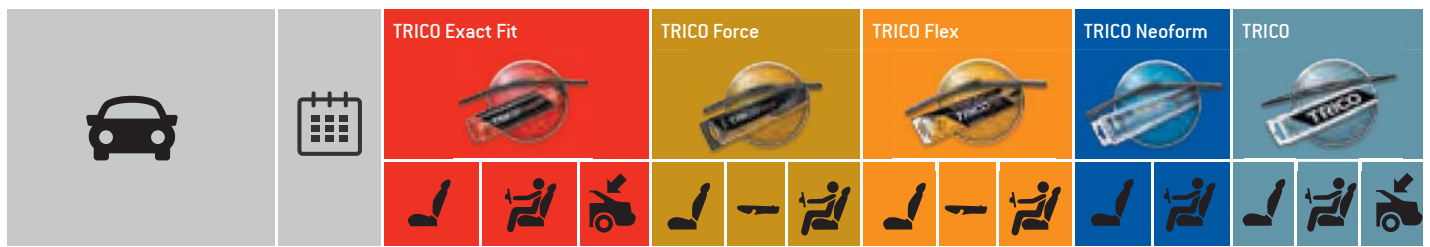

...HONDA

...CIVIC	83	87	EF430	EF430	EF380	TF430L	A/D	TF430L	FX430	A/D	FX430	NF430	NF430	T430	T430	T380
	87	90	EF480	EF450		TF480L	A/D	TF450L	FX480	A/D	FX450	NF480	NF450	T480	T450	
	91	01	EF500	EF450	EF450	TF500L	A/D	TF450L	FX500	A/D	FX450	NF500	NF450	T500	T450	T450
	00	05	EF600	EF380	EX300	TF600L	A/D	TF350L	FX600	A/D	FX350	NF600	NF350	T600	T380	
	12		HF650	HF450	HF450	TF650L	A/D	TF450L	FX650	A/D	FX450	NF650	NF450			T450
	83	95	EF430	EF430	EF380	TF430L	A/D	TF430L	FX430	A/D	FX430	NF430	NF430	T430	T430	T380
	98	01	EF500	EF450	EF380	TF500L	A/D	TF450L	FX500	A/D	FX450	NF500	NF450	T500	T450	T380
	12		HF650	HF450	EX306	TF650L	A/D	TF450L	FX650	A/D	FX450	NF650	NF450			
	93	00	EF500	EF450		TF500L	A/D	TF450L	FX500	A/D	FX450	NF500	NF450	T500	T450	
	01	05	EF530	EF480		TF530L	A/D	TF480L	FX530	A/D	FX480	NF530	NF480	T530	T480	
	12		HF650	HF450		TF650L	A/D	TF450L	FX650	A/D	FX450	NF650	NF450			
CONCERTO	89	95	EF450	EF450		TF450L	A/D	TF450L	FX450	A/D	FX450	NF450	NF450	T450	T450	
	89	96	EF450	EF450	EF450	TF450L	A/D	TF450L	FX450	A/D	FX450	NF450	NF450	T450	T450	T450
CR-V	95	02	EF480	EF480	EF280	TF480L	A/D	TF480L	FX480	A/D	FX480	NF480	NF480	T480	T480	T280
	02	06	EF530	EF500		TF530L	A/D	TF500L	FX530	A/D	FX500	NF530	NF500	T530	T500	
	06	12	HF650	HF430	EX351	TF650L	A/D	TF430L	FX650	A/D	FX430	NF650	NF430			
	13		HF650	HF400	EF280	TF650L	A/D	TF400L	FX650	A/D	FX400	NF650	NF400			T280
CRX	83	92	EF450	EF450		TF450L	A/D	TF450L	FX450	A/D	FX450	NF450	NF450	T450	T450	
	92	98	EF500	EF450		TF500L	A/D	TF450L	FX500	A/D	FX450	NF500	NF450	T500	T450	
CR-Z	10		HF650	HF500		TF650L	A/D	TF500L	FX650	A/D	FX500	NF650	NF500			
ELEMENT	02		EF500	EF500		TF500L	A/D	TF500L	FX500	A/D	FX500	NF500	NF500	T500	T500	
FR-V	04		EF650	EF480		TF650L	A/D	TF480L	FX650	A/D	FX480	NF650	NF480	T650	T480	
MPV	04		EF650	EF480		TF650L	A/D	TF480L	FX650	A/D	FX480	NF650	NF480	T650	T480	
HR-V	99	06	EF500	EF430		TF500L	A/D	TF430L	FX500	A/D	FX430	NF500	NF430	T500	T430	
	15		EF650	EF450	EX252	TF650L	A/D	TF450L	FX650	A/D	FX450	NF650	NF450			
INSIGHT	00	06	EF500	EF450		TF500L	A/D	TF450L	FX500	A/D	FX450	NF500	NF450	T500	T450	
	08		HF650	HF400		TF650L	A/D	TF400L	FX650	A/D	FX400	NF650	NF400	T650	T400	
INTEGRA	89	93	EF450	EF450		TF450L	A/D	TF450L	FX450	A/D	FX450	NF450	NF450	T450	T450	
	85	89	EF450	EF450	EF450	TF450L	A/D	TF450L	FX450	A/D	FX450	NF450	NF450	T450	T450	T450
	93		EF500	EF450		TF500L	A/D	TF450L	FX500	A/D	FX450	NF500	NF450	T500	T450	
JAZZ	03	08	EF500	EF380		TF500L	A/D	TF350L	FX500	A/D	FX350	NF500	NF350	T500	T380	
	09		HF650	HF350		TF650L	A/D	TF350L	FX650	A/D	FX350	NF650	NF350			
	83	86	EF430*	EF430*	EF330									T430*	T430*	T330
	02	08	EF500	EF380	EX351	TF500L	A/D	TF350L	FX500	A/D	FX350	NF500	NF350	T500	T380	
	09	14	HF650	HF350	EX351	TF650L	A/D	TF350L	FX650	A/D	FX350	NF650	NF350			
LAGREAT	94	02	EF600	EF530	EF430	TF600L	A/D	TF530L	FX600	A/D	FX530	NF600	NF530	T600	T530	T430
LEGEND	86	90	EF500	EF500		TF500L	A/D	TF500L	FX500	A/D	FX500	NF500	NF500	T500	T500	
	91	96	EF500	EF480		TF500L	A/D	TF480L	FX500	A/D	FX480	NF500	NF480	T500	T480	
	87	90	EF500	EF500		TF500L	A/D	TF500L	FX500	A/D	FX500	NF500	NF500	T500	T500	
	91	96	EF500	EF480		TF500L	A/D	TF480L	FX500	A/D	FX480	NF500	NF480	T500	T480	
LOGO	99	02	EF500	EF430		TF500L	A/D	TF430L	FX500	A/D	FX430	NF500	NF430	T500	T430	
NSX	90	05	EF500	EF500		TF500L	A/D	TF500L	FX500	A/D	FX500	NF500	NF500	T500	T500	
	95	05	EF500	EF500		TF500L	A/D	TF500L	FX500	A/D	FX500	NF500	NF500	T500	T500	
ODYSSEY	97	02	EF600	EF530	EF430	TF600L	A/D	TF530L	FX600	A/D	FX530	NF600	NF530	T600	T530	T430
PRELUDE	78	82	EF430*	EF430*										T430*	T430*	
	83	87	EF450*	EF450*	EF380									T450*	T450*	T380



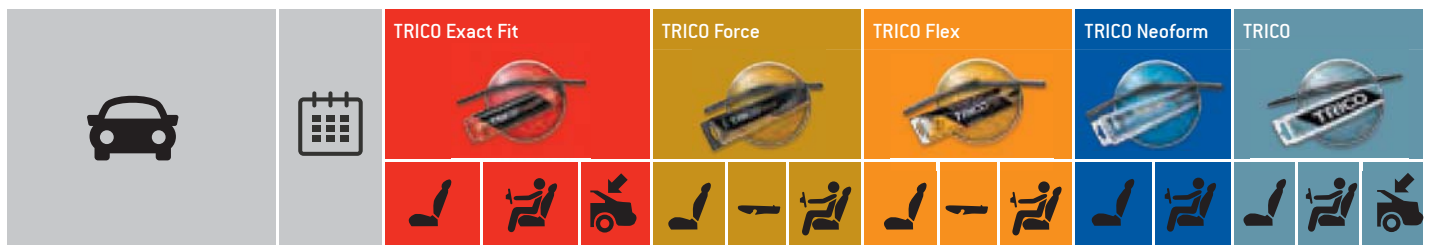

...HONDA																	
...PRELUDE	86	96	EF480	EF450		TF480L	A/D	TF450L	FX480	A/D	FX450	NF480	NF450	T480	T450		
	92	02	EF500	EF480		TF500L	A/D	TF480L	FX500	A/D	FX480	NF500	NF480	T500	T480		
QUINTET	80	84	EF430	EF430		TF430L	A/D	TF430L	FX430	A/D	FX430	NF430	NF430	T430	T430		
RIDGELINE	05		EF600	EF550		TF600L	A/D	TF550L	FX600	A/D	FX550	NF600	NF550	T600	T550		
S2000	99		EF400	EF500		TF400L	A/D	TF500L	FX400	A/D	FX500	NF400	NF500	T400	T500		
SHUTTLE	94	04	EF550	EF550	EF380	TF550L	A/D	TF550L	FX550	A/D	FX550	NF550	NF550	T550	T550	T380	
STREAM	01		EF600	EF350		TF600L	A/D	TF350L	FX600	A/D	FX350	NF600	NF350	T600	T350		
HUMMER																	
HUMMER	92	02	EF430	EF430		TF430L	A/D	TF430L	FX430	A/D	FX430	NF430	NF430	T430	T430		
	02	09	EF400	EF400		TF400L	A/D	TF400L	FX400	A/D	FX400	NF400	NF400	T400	T400		
HYUNDAI																	
ACCENT		94	07	EF500	EF450		TF500L	A/D	TF450L	FX500	A/D	FX450	NF500	NF450	T500	T450	
		94	07	EF500	EF450	EF500	TF500L	A/D	TF450L	FX500	A/D	FX450	NF500	NF450	T500	T450	T500
AMICA		98	06	EF500	EF400	EF350	TF500L	A/D	TF400L	FX500	A/D	FX400	NF500	NF400	T500	T400	T350
ATOS		98	06	EF500	EF400	EF350	TF500L	A/D	TF400L	FX500	A/D	FX400	NF500	NF400	T500	T400	T350
ATOS PRIME		99	06	EF500	EF400	EF400	TF500L	A/D	TF400L	FX500	A/D	FX400	NF500	NF400	T500	T400	T400
COUPE		96	09	EF550	EF450	EF500	TF550L	A/D	TF450L	FX550	A/D	FX450	NF550	NF450	T550	T450	T500
ELANTRA		00	06	EF500	EF450		TF500L	A/D	TF450L	FX500	A/D	FX450	NF500	NF450	T500	T450	
		06	11	EF600	EF450		TF600L	A/D	TF450L	FX600	A/D	FX450	NF600	NF450	T600	T450	
		00	06	EF500	EF450	EF380	TF500L	A/D	TF450L	FX500	A/D	FX450	NF500	NF450	T500	T450	T380
EQUUS		09		HF600	HF500		TF600L	A/D	TF500L	FX600	A/D	FX500	NF600	NF500	T600	T500	
GALLOPER		91	98	EF430	EF430	EF350	TF430L	A/D	TF430L	FX430	A/D	FX430	NF430	NF430	T430	T430	T350
GETZ		02	09	EF550	EF350	EF350	TF550L	A/D	TF350L	FX550	A/D	FX350	NF550	NF350	T550	T350	T350
GRANDEUR		05		EF600	EF500		TF600L	A/D	TF500L	FX600	A/D	FX500	NF600	NF500	T600	T500	
H-1		00		EF650	EF500		TF650L	A/D	TF500L	FX650	A/D	FX500	NF650	NF500	T650	T500	
		08		EF600	EF500		TF600L	A/D	TF500L	FX600	A/D	FX500	NF600	NF500	T600	T500	
H-1 / STAREX	MPV	97	07	EF650	EF500	EF380	TF650L	A/D	TF500L	FX650	A/D	FX500	NF650	NF500	T650	T500	T380
		97	07	EF650	EF500		TF650L	A/D	TF500L	FX650	A/D	FX500	NF650	NF500	T650	T500	
H100		93	04	EF450	EF450		TF450L	A/D	TF450L	FX450	A/D	FX450	NF450	NF450	T450	T450	
H350		14		EF650	EF600		TF650L	A/D	TF600L	FX650	A/D	FX600	NF650	NF600	T650	T600	
i10		07	13	EF550	EF400		TF550L	A/D	TF400L	FX550	A/D	FX400	NF550	NF400	T550	T400	
		14		HF550	HF400		TF550L	A/D	TF400L	FX550	A/D	FX400	NF550	NF400	T550	T400	
i20		08	14	EF600	EF400	EX305	TF600L	A/D	TF400L	FX600	A/D	FX400	NF600	NF400	T600	T400	
		15		HF600	HF400	EX300	TF600L	A/D	TF400L	FX600	A/D	FX400	NF600	NF400			
i30		07	11	EFB6018L	EFB4518L	EX309	TF600L	BC	TF450L	FX600	BC	FX450	NF609	NF459			
		11		HF650	HF350		TF650L	A/D	TF350L	FX650	A/D	FX350	NF650	NF350	T650	T350	
		07	11	EFB6018L	EFB4518L	EX309	TF600L	BC	TF450L	FX600	BC	FX450	NF609	NF459			
		12		HF650	HF350		TF650L	A/D	TF350L	FX650	A/D	FX350	NF650	NF350	T650	T350	
i40		12		HF650	HF400		TF650L	A/D	TF400L	FX650	A/D	FX400	NF650	NF400	T650	T400	
		11		HF650	HF400		TF650L	A/D	TF400L	FX650	A/D	FX400	NF650	NF400	T650	T400	
ix20		10		EFB6518L	EFB3518L	EX300	TF650L	BC	TF350L	FX650	BC	FX350	NF659	NF359			
ix35		10		HF600	HF400	EX309	TF600L	A/D	TF400L	FX600	A/D	FX400	NF600	NF400	T600	T400	
ix55		08		EFB6018L	EFB5018L		TF600L	BC	TF500L	FX600	BC	FX500	NF609	NF509			
i800		08		EF600	EF500	EX350	TF600L	A/D	TF500L	FX600	A/D	FX500	NF600	NF500	T600	T400	
iLoad		08		EF600	EF500		TF600L	A/D	TF500L	FX600	A/D	FX500	NF600	NF500	T600	T400	
LANTRA		90	95	EF500	EF480		TF500L	A/D	TF480L	FX500	A/D	FX480	NF500	NF480	T500	T480	

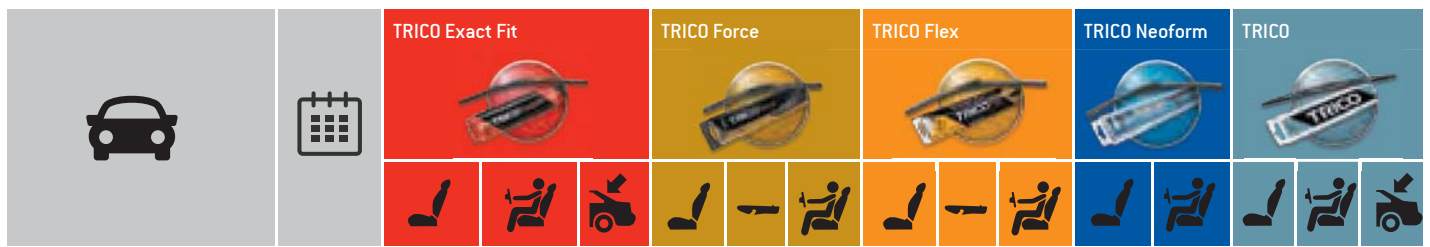

...HYUNDAI

...LANTRA	95	00	EF500	EF450		TF500L	A/D	TF450L	FX500	A/D	FX450	NF500	NF450	T500	T450	
	96	00	EF500	EF450	EF380	TF500L	A/D	TF450L	FX500	A/D	FX450	NF500	NF450	T500	T450	T380
MATRIX	01	10	EF550	EF400	EF350	TF550L	A/D	TF400L	FX550	A/D	FX400	NF550	NF400	T550	T400	T350
PONY / EXCEL	90	95	EF450	EF450		TF450L	A/D	TF450L	FX450	A/D	FX450	NF450	NF450	T450	T450	
	85	89	EF430*	EF430*										T430*	T430*	
	74	84	EF400	EF400	EF400	TF400L	A/D	TF400L	FX400	A/D	FX400	NF400	NF400	T400	T400	T400
	85	89	EF430*	EF430*										T430*	T430*	
	89	95	EF450	EF450		TF450L	A/D	TF450L	FX450	A/D	FX450	NF450	NF450	T450	T450	
	78	95	EF400	EF400		TF400L	A/D	TF400L	FX400	A/D	FX400	NF400	NF400	T400	T400	
PORTER	94	04	EF450	EF450		TF450L	A/D	TF450L	FX450	A/D	FX450	NF450	NF450	T450	T450	
SANTA FÉ	00	04	EF550	EF500	EF330	TF550L	A/D	TF500L	FX550	A/D	FX500	NF550	NF500	T550	T500	T330
	04	11	EF600	EF450	EX350	TF600L	A/D	TF450L	FX600	A/D	FX450	NF600	NF450	T600	T450	
	12		HF650	HF350		TF650L	A/D	TF350L	FX650	A/D	FX350	NF650	NF350	T650	T350	
SANTAMO	98		EF550	EF450	EF400	TF550L	A/D	TF450L	FX550	A/D	FX450	NF550	NF450	T550	T450	T400
S COUPE	90	96	EF480	EF450		TF480L	A/D	TF450L	FX480	A/D	FX450	NF480	NF450	T480	T450	
SONATA	88	93	EF500	EF450		TF500L	A/D	TF450L	FX500	A/D	FX450	NF500	NF450	T500	T450	
	93	98	EF500	EF500		TF500L	A/D	TF500L	FX500	A/D	FX500	NF500	NF500	T500	T500	
	98	05	EF550	EF500		TF550L	A/D	TF500L	FX550	A/D	FX500	NF550	NF500	T550	T500	
	05	11	EF600	EF500		TF600L	A/D	TF500L	FX600	A/D	FX500	NF600	NF500	T600	T500	
	12		HF650	HF450		TF650L	A/D	TF450L	FX650	A/D	FX450	NF650	NF450	T650	T450	
STELLAR	83	91	EF450	EF450		TF450L	A/D	TF450L	FX450	A/D	FX450	NF450	NF450	T450	T450	
TERRACAN	01	06	EF550	EF500	EF400	TF550L	A/D	TF500L	FX550	A/D	FX500	NF550	NF500	T550	T500	T400
TIBURON	06		EF550	EF450		TF550L	A/D	TF450L	FX550	A/D	FX450	NF550	NF450	T550	T450	
TRAJET	00	08	EF650	EF550	EF400	TF650L	A/D	TF550L	FX650	A/D	FX550	NF650	NF550	T650	T550	T400
TUCSON	04	10	EF600	EF400		TF600L	A/D	TF400L	FX600	A/D	FX400	NF600	NF400	T600	T400	
	15		HF650	HF400		TF650L	A/D	TF400L	FX650	A/D	FX400	NF650	NF400			
VELOSTER	11		HF650	HF450		TF650L	A/D	TF450L	FX650	A/D	FX450	NF650	NF450	T650	T450	
VERACRUZ	08		EFB6018L	EFB5018L		TF600L	BC	TF500L	FX600	BC	FX500	NF609	NF509			
XG	98		EF550	EF500		TF550L	A/D	TF500L	FX550	A/D	FX500	NF550	NF500	T550	T500	

INFINITI

EX	10		HF600	HF430	EX351	TF600L	A/D	TF430L	FX600	A/D	FX430	NF600	NF430	T600	T430	
FX	03	08	EF550	EF500		TF550L	A/D	TF500L	FX550	A/D	FX500	NF550	NF500	T550	T500	
	08		HF550	HF480	EX351	TF550L	A/D	TF480L	FX550	A/D	FX480	NF550	NF480	T550	T480	
	08		HF650	HF430		TF650L	A/D	TF430L	FX650	A/D	FX430	NF650	NF430	T650	T430	
	10		HF650	HF430		TF650L	A/D	TF430L	FX650	A/D	FX430	NF650	NF430	T650	T430	
	10		HF650	HF430		TF650L	A/D	TF430L	FX650	A/D	FX430	NF650	NF430	T650	T430	
G20	90	97	EF530	EF480		TF530L	A/D	TF480L	FX530	A/D	FX480	NF530	NF480	T530	T480	
I30	97		EF600	EF430		TF600L	A/D	TF430L	FX600	A/D	FX430	NF600	NF430	T600	T430	
M	10		HF650	HF480		TF650L	A/D	TF480L	FX650	A/D	FX480	NF650	NF480	T650	T480	
	89	93	EF530	EF480		TF530L	A/D	TF480L	FX530	A/D	FX480	NF530	NF480	T530	T480	
	90	93	EF530	EF480		TF530L	A/D	TF480L	FX530	A/D	FX480	NF530	NF480	T530	T480	
M35	05		EF600	EF480		TF600L	A/D	TF480L	FX600	A/D	FX480	NF600	NF480	T600	T480	
M45	05		EF600	EF480		TF600L	A/D	TF480L	FX600	A/D	FX480	NF600	NF480	T600	T480	
Q45	89		EF600	EF450		TF600L	A/D	TF450L	FX600	A/D	FX450	NF600	NF450	T600	T450	
Q50	13		HF650	HF430		TF650L	A/D	TF430L	FX650	A/D	FX430	NF650	NF430	T650	T430	
Q60	13		HF650	HF430		TF650L	A/D	TF430L	FX650	A/D	FX430	NF650	NF430	T650	T430	





...INFINITI

QX4	97		EF550	EF530		TF550L	A/D	TF530L	FX550	A/D	FX530	NF550	NF530	T550	T530	
QX70	13		HF650	HF480		TF600L	A/D	TF480L	FX650	A/D	FX480	NF600	NF480			

INNOCENTI

MINI	74	95	EF280	EF280										T280	T280	
------	----	----	-------	-------	--	--	--	--	--	--	--	--	--	------	------	--

IRMSCHER

COUPE	97		EF500	EF480		TF500L	A/D	TF480L	FX500	A/D	FX480	NF500	NF480	T500	T480	
GT	88	90	EF450	EF450		TF450L	A/D	TF450L	FX450	A/D	FX450	NF450	NF450	T450	T450	
OMEGA	90	96	EF480	EF480		TF480L	A/D	TF480L	FX480	A/D	FX480	NF480	NF480	T480	T480	
SENATOR	90	96	EF480	EF480		TF480L	A/D	TF480L	FX480	A/D	FX480	NF480	NF480	T480	T480	

ISUZU

ASCENDER	03		EF550	EF550	EF400	TF550L	A/D	TF550L	FX550	A/D	FX550	NF550	NF550	T550	T550	T400
CAMPO	77	91	EF450	EF450		TF450L	A/D	TF450L	FX450	A/D	FX450	NF450	NF450	T450	T450	
D-MAX	02	11	EF550	EF480		TF550L	A/D	TF480L	FX550	A/D	FX480	NF550	NF480	T550	T480	
	12		EF550	EF450		TF550L	A/D	TF450L	FX550	A/D	FX450	NF550	NF450	T550	T450	
ELF	85	03	EF500	EF500		TF500L	A/D	TF500L	FX500	A/D	FX500	NF500	NF500	T500	T500	
GEMINI	74	93	EF450	EF450		TF450L	A/D	TF450L	FX450	A/D	FX450	NF450	NF450	T450	T450	
			88	93	EF450	EF450	EF400	TF450L	A/D	TF450L	FX450	A/D	FX450	NF450	NF450	T450
IMPULSE	90	93	EF550	EF550		TF550L	A/D	TF550L	FX550	A/D	FX550	NF550	NF550	T550	T550	
MIDI	88		EF450	EF450	EF400	TF450L	A/D	TF450L	FX450	A/D	FX450	NF450	NF450	T450	T450	T400
PIAZZA	85	90	EF450*	EF450*										T450*	T450*	
PICK UP	79	96	EF450	EF450										T450	T450	
TFR/TFS	88	99	EF450	EF450		TF450L	A/D	TF450L	FX450	A/D	FX450	NF450	NF450	T450	T450	
TROOPER	83	91	EF430	EF430	EF400*	TF430L	A/D	TF430L	FX430	A/D	FX430	NF430	NF430	T430	T430	T400*
			91	02	EF500	EF500	EF400*	TF500L	A/D	TF500L	FX500	A/D	FX500	NF500	NF500	T500

IVECO

DAILY	78	99	EF550	EF550		TF550L	A/D	TF550L	FX550	A/D	FX550	NF550	NF550	T550	T550	
		99	EF603	EF603												

JAGUAR

E-TYPE	61	75	EF380	EF380		TF350L	A/D	TF350L	FX350	A/D	FX350	NF350	NF350	T380	T380	
F-TYPE	13		EF550	EF530		TF550L	A/D	TF530L	FX550	A/D	FX530	NF550	NF530	T550	T530	
S-TYPE	99	04	EF550	EF550		TF550L	A/D	TF550L	FX550	A/D	FX550	NF550	NF550	T550	T550	
	04	08	EF603	EF453												
XE	15		EFB6518L	EFB4318L		TF650L	BC	TF430L	FX640	BC	FX430	NF659	NF439			
XF	08		EFB6017L	EFB4817L		TF600L	BC	TF480L	FX600	BC	FX480	NF607	NF487			
		13		EFB6017L	EFB4817L	EX282	TF600L	BC	TF480L	FX600	BC	FX480	NF607	NF487		
XJ	68	79	EF380	EF380		TF350L	A/D	TF350L	FX350	A/D	FX350	NF350	NF350	T380	T380	
	79	92	EF400*	EF400*										T400*	T400*	
	92	03	EF530			TF530L	A/D		FX530	A/D		NF530		T530		
	03	09	EF603	EF453												
	09		EFB6017L	EFB4817L		TF600L	BC	TF480L	FX600	BC	FX480	NF607	NF487			
XJS	73	96	EF380	EF380		TF350L	A/D	TF350L	FX350	A/D	FX350	NF350	NF350	T380	T380	
			85	96	EF380	EF380		TF350L	A/D	TF350L	FX350	A/D	FX350	NF350	NF350	T380
XK	06		HF530	HF530		TF530L	A/D	TF530L	FX530	A/D	FX530	NF530	NF530	T530	T530	
		06		HF530	HF530		TF530L	A/D	TF530L	FX530	A/D	FX530	NF530	NF530	T530	T530
XK 8	96	07	HF530	HF530		TF530L	A/D	TF530L	FX530	A/D	FX530	NF530	NF530	T530	T530	
			96	07	HF530	HF530		TF530L	A/D	TF530L	FX530	A/D	FX530	NF530	NF530	T530



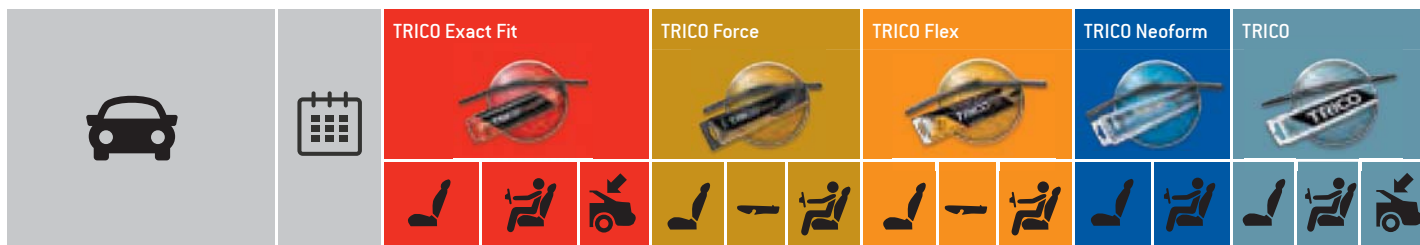

...JAGUAR

X-TYPE		01	09	EF550	EF480		TF550L	A/D	TF480L	FX550	A/D	FX480	NF550	NF480	T550	T480	
		03	09	EF550	EF480	EX357	TF550L	A/D	TF480L	FX550	A/D	FX480	NF550	NF480	T550	T480	

JEEP

CHEROKEE		80	00	EF450	EF450	EF330	TF450L	A/D	TF450L	FX450	A/D	FX450	NF450	NF450	T450	T450	T330
		01	08	EF450	EF450	EF280	TF450L	A/D	TF450L	FX450	A/D	FX450	NF450	NF450	T450	T450	T280
		08	13	EF480	EF480		TF480L	A/D	TF480L	FX480	A/D	FX480	NF480	NF480	T480	T480	
		14		HF650	HF450	EX351	TF650L	A/D	TF450L	FX650	A/D	FX450	NF650	NF450			
CJ5 - CJ8		66	87	EF280	EF280										T280	T280	
COMMANDER		05	10	EF450	EF450		TF450L	A/D	TF450L	FX450	A/D	FX450	NF450	NF450	T450	T450	
COMPASS		06		EF500	EF500	EF280	TF500L	A/D	TF500L	FX500	A/D	FX500	NF500	NF500	T500	T500	T280
GRAND CHEROKEE		91	99	EF500	EF500	EF280	TF500L	A/D	TF500L	FX500	A/D	FX500	NF500	NF500	T500	T500	T280
		99	05	EF530	EF530	EF280	TF530L	A/D	TF530L	FX530	A/D	FX530	NF530	NF530	T530	T530	T280
		05	10	EF530	EF530	EX305	TF530L	A/D	TF530L	FX530	A/D	FX530	NF530	NF530	T530	T530	
		10	12	EF530	EF530	EX280	TF530L	A/D	TF530L	FX530	A/D	FX530	NF530	NF530	T530	T530	
		13		HF530	HF530	EX280	TF530L	A/D	TF530L	FX530	A/D	FX530	NF530	NF530	T530	T530	
PATRIOT		07		EF530	EF530	EF280	TF530L	A/D	TF530L	FX530	A/D	FX530	NF530	NF530	T530	T530	T280
RENEGADE		15		EFB5318L	EFB5018L	EX254	TF550L	BC	TF500L	FX550	BC	FX500	NF557	NF509			
WRANGLER		86	08	EF330	EF330	EF450	TF350L	A/D	TF350L	FX350	A/D	FX350	NF350	NF350	T330	T330	T450
		07		EF380	EF380		TF350L	A/D	TF350L	FX350	A/D	FX350	NF350	NF350	T380	T380	

JENSEN

S-V8		98	07	EF450	EF450		TF450L	A/D	TF450L	FX450	A/D	FX450	NF450	NF450	T450	T450	
------	--	----	----	-------	-------	--	--------	-----	--------	-------	-----	-------	-------	-------	------	------	--

KIA

AVELLA		95	01	EF500	EF400		TF500L	A/D	TF400L	FX500	A/D	FX400	NF500	NF400	T500	T400	
		95	01	EF500	EF400		TF500L	A/D	TF400L	FX500	A/D	FX400	NF500	NF400	T500	T400	
BESTA		96		EF450	EF450		TF450L	A/D	TF450L	FX450	A/D	FX450	NF450	NF450	T450	T450	
CARENS		00	05	EF600	EF480	EF350	TF600L	A/D	TF480L	FX600	A/D	FX480	NF600	NF480	T600	T480	T350
		06	12	EF600	EF480	EX350	TF600L	A/D	TF480L	FX600	A/D	FX480	NF600	NF480	T600	T480	T350
		13		HF700	HF700		TF700L	A/D	TF700L	FX700	A/D	FX700	NF700	NF700			
CARNIVAL		99	01	EF600	EF600	EF450	TF600L	A/D	TF600L	FX600	A/D	FX600	NF600	NF600	T600	T600	T450
		01		EF650	EF450	EF450	TF650L	A/D	TF450L	FX650	A/D	FX450	NF650	NF450	T650	T450	T450
CEE'D		06	11	EFB6018L	EFB4518L	EX309	TF600L	BC	TF450L	FX600	BC	FX450	NF609	NF459			
		12		HF650	HF350		TF650L	A/D	TF350L	FX650	A/D	FX350	NF650	NF350	T650	T350	
		07	11	EFB6018L	EFB4518L	EX309	TF600L	BC	TF450L	FX600	BC	FX450	NF609	NF459			
		12		HF650	HF350		TF650L	A/D	TF350L	FX650	A/D	FX350	NF650	NF350	T650	T350	
CERATO		04		EF600	EF400		TF600L	A/D	TF400L	FX600	A/D	FX400	NF600	NF400	T600	T400	
		04		EF600	EF400		TF600L	A/D	TF400L	FX600	A/D	FX400	NF600	NF400	T600	T400	
CLARUS		96		EF530	EF480		TF530L	A/D	TF480L	FX530	A/D	FX480	NF530	NF480	T530	T480	
		98		EF530	EF480		TF530L	A/D	TF480L	FX530	A/D	FX480	NF530	NF480	T530	T480	
JOICE		00		EF550	EF550		TF550L	A/D	TF550L	FX550	A/D	FX550	NF550	NF550	T550	T550	
K2500		03		EF450	EF450		TF450L	A/D	TF450L	FX450	A/D	FX450	NF450	NF450	T450	T450	
K2700		97		EF450	EF450		TF450L	A/D	TF450L	FX450	A/D	FX450	NF450	NF450	T450	T450	
MAGENTIS		01	04	EF550	EF500		TF550L	A/D	TF500L	FX550	A/D	FX500	NF550	NF500	T550	T500	
		05		EF600	EF450		TF600L	A/D	TF450L	FX600	A/D	FX450	NF600	NF450	T600	T450	
OPIRUS		03		EF600	EF450		TF600L	A/D	TF450L	FX600	A/D	FX450	NF600	NF450	T600	T450	
OPTIMA		13		HF600	HF450		TF600L	A/D	TF450L	FX600	A/D	FX450	NF600	NF450	T600	T450	
PICANTO		04	11	EF550	EF400	EX308	TF550L	A/D	TF400L	FX550	A/D	FX400	NF550	NF400	T550	T400	



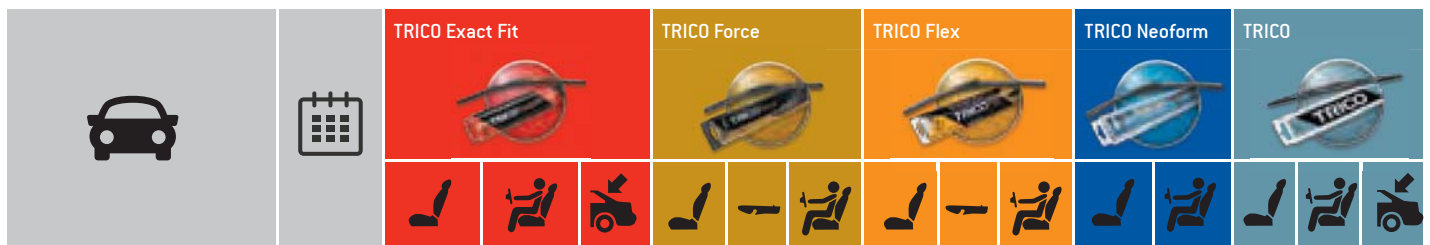

...KIA

...PICANTO	11		EF550	EF400		TF550L	A/D	TF400L	FX550	A/D	FX400	NF550	NF400	T550	T400	
PREGIO	97		EF530	EF450		TF530L	A/D	TF450L	FX530	A/D	FX450	NF530	NF450	T530	T450	
PRIDE	90	04	EF450	EF450	EF380	TF450L	A/D	TF450L	FX450	A/D	FX450	NF450	NF450	T450	T450	T380
	99	04	EF450	EF450	EF380	TF450L	A/D	TF450L	FX450	A/D	FX450	NF450	NF450	T450	T450	T380
PRO CEE'D	08	11	EFB6018L	EFB4518L	EX309	TF600L	BC	TF450L	FX600	BC	FX450	NF609	NF459			
RETONA	99		EF350	EF350		TF350L	A/D	TF350L	FX350	A/D	FX350	NF350	NF350	T350	T350	
RIO	00	04	EF530	EF450	EF350	TF530L	A/D	TF450L	FX530	A/D	FX450	NF530	NF450	T530	T450	T350
	05	11	EF550	EF400		TF550L	A/D	TF400L	FX550	A/D	FX400	NF550	NF400	T550	T400	
	12		HF650	HF400		TF650L	A/D	TF400L	FX650	A/D	FX400	NF650	NF400	T650	T400	
	05	11	EF550	EF400	EX350	TF550L	A/D	TF400L	FX550	A/D	FX400	NF550	NF400	T550	T400	
	12		HF650	HF400	EX280	TF650L	A/D	TF400L	FX650	A/D	FX400	NF650	NF400	T650	T400	
	00	05	EF530	EF450	EF350	TF530L	A/D	TF450L	FX530	A/D	FX450	NF530	NF450	T530	T450	T350
ROADSTER	99		EF550	EF550		TF550L	A/D	TF550L	FX550	A/D	FX550	NF550	NF550	T550	T550	
SEPHIA	93	97	EF530	EF480	EF450	TF530L	A/D	TF480L	FX530	A/D	FX480	NF530	NF480	T530	T480	T450
	95	97	EF530	EF480	EF450	TF530L	A/D	TF480L	FX530	A/D	FX480	NF530	NF480	T530	T480	T450
SHUMA	96	04	EF530	EF480		TF530L	A/D	TF480L	FX530	A/D	FX480	NF530	NF480	T530	T480	
	97	04	EF530	EF480	EF450	TF530L	A/D	TF480L	FX530	A/D	FX480	NF530	NF480	T530	T480	T450
SORENTO	02	10	EF600	EF450	EF350	TF600L	A/D	TF450L	FX600	A/D	FX450	NF600	NF450	T600	T450	T350
	11	14	HF600	HF500		TF600L	A/D	TF500L	FX600	A/D	FX500	NF600	NF500	T600	T500	
	15		HF650	HF400	EX309	TF650L	A/D	TF400L	FX650	A/D	FX400	NF650	NF400			
SOUL	09		EF600	EF500	EX280	TF600L	A/D	TF500L	FX600	A/D	FX500	NF600	NF500	T600	T500	
SPORTAGE	94	03	EF500	EF500	EF400	TF500L	A/D	TF500L	FX500	A/D	FX500	NF500	NF500	T500	T500	T400
	04	09	EF600	EF400	EX330	TF600L	A/D	TF400L	FX600	A/D	FX400	NF600	NF400	T600	T400	T330
	10		HF600	HF450	EX309	TF600L	A/D	TF450L	FX600	A/D	FX450	NF600	NF450	T600	T450	
VENGA	10		EFB6518L	EFB3518L	EX300	TF650L	BC	TF350L	FX650	BC	FX350	NF659	NF359			

LADA

110	95		EF500	EF500		TF500L	A/D	TF500L	FX500	A/D	FX500	NF500	NF500	T500	T500	
111	95		EF500	EF500	EF280	TF500L	A/D	TF500L	FX500	A/D	FX500	NF500	NF500	T500	T500	T280
112	95		EF500	EF500	EF280	TF500L	A/D	TF500L	FX500	A/D	FX500	NF500	NF500	T500	T500	T280
1200-1500	73	85	EF330	EF330										T330	T330	
1200-1600	70	90	EF330	EF330										T330	T330	
KALINA	04		EF600	EF400		TF600L	A/D	TF400L	FX600	A/D	FX400	NF600	NF400	T600	T400	
	04		EF600	EF400	EF400	TF600L	A/D	TF400L	FX600	A/D	FX400	NF600	NF400	T600	T400	T400
	04		EF600	EF400		TF600L	A/D	TF400L	FX600	A/D	FX400	NF600	NF400	T600	T400	
NADESCHDA	97		EF500	EF500		TF500L	A/D	TF500L	FX500	A/D	FX500	NF500	NF500	T500	T500	
NIVA	02		EF330	EF330	EF330									T330	T330	T330
	SUV	76	EF330	EF330	EF280									T330	T330	T280
NOVA	81		EF330	EF330										T330	T330	
	85		EF330	EF330										T330	T330	
PRIORA	08		EF500	EF500		TF500L	A/D	TF500L	FX500	A/D	FX500	NF500	NF500	T500	T500	
	08		EF500	EF500	EF500	TF500L	A/D	TF500L	FX500	A/D	FX500	NF500	NF500	T500	T500	T500
TOSCANA	83	12	EF330	EF330										T330	T330	

LANCIA

A 112	78	86	EF380	EF380		TF350L	A/D	TF350L	FX350	A/D	FX350	NF350	NF350	T380	T380	
BETA	73	84	EF450*	EF450*										T450*	T450*	T430*
	76	84	EF450*	EF450*										T450*	T450*	



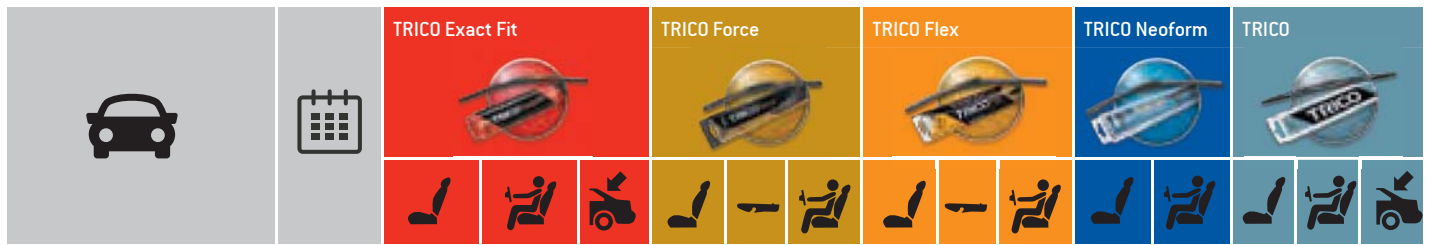

...LANCIA

...BETA		75	81	EF450*	EF450*										T450*	T450*	
DEDRA		89	99	EF530	EF480		TF530L	A/D	TF480L	FX530	A/D	FX480	NF530	NF480	T530	T480	
		94	99	EF530	EF480		TF530L	A/D	TF480L	FX530	A/D	FX480	NF530	NF480	T530	T480	
DELTA		79	94	EF450	EF450	EF450	TF450L	A/D	TF450L	FX450	A/D	FX450	NF450	NF450	T450	T450	T450
		93	99	EF530	EF480	EF530	TF530L	A/D	TF480L	FX530	A/D	FX480	NF530	NF480	T530	T480	T530
		08		EFB6018L	EFB4318L	EX300	TF600L	BC	TF430L	FX600	BC	FX430	NF609	NF439			
FULVIA		65	76	EF330	EF330										T330	T330	
GAMMA		81	84	EF450*	EF450*										T450*	T450*	
		81	84	EF450	EF450		TF450L	A/D	TF450L	FX450	A/D	FX450	NF450	NF450	T450	T450	
KAPPA		94	01	EF600	EF530		TF600L	A/D	TF530L	FX600	A/D	FX530	NF600	NF530	T600	T530	
		96	01	EF600	EF530		TF600L	A/D	TF530L	FX600	A/D	FX530	NF600	NF530	T600	T530	
		96	01	EF600	EF530		TF600L	A/D	TF530L	FX600	A/D	FX530	NF600	NF530	T600	T530	
LYBRA		99	05	EF550	EF530		TF550L	A/D	TF530L	FX550	A/D	FX530	NF550	NF530	T550	T530	
		99	05	EF550	EF530		TF550L	A/D	TF530L	FX550	A/D	FX530	NF550	NF530	T550	T530	
MUSA		04	08	EF580	EF380		TF550L	A/D	TF350L	FX550	A/D	FX350	NF550	NF350	T580	T380	
		09		EFB5318L	EFB3518L		TF530L	BC	TF350L	FX530	BC	FX350	NF539	NF359			
PHEDRA		02	06	EF653	EF653	EX353											
		06	10	EF650	EF650	EX353	TF650L	A/D	TF650R	FX650	A/D	FX650	NF650	NF650	T650	T650	
PRISMA		83	92	EF450	EF450		TF450L	A/D	TF450L	FX450	A/D	FX450	NF450	NF450	T450	T450	
THEMA		87	94	EF500	EF500	EF380	TF500L	A/D	TF500L	FX500	A/D	FX500	NF500	NF500	T500	T500	T380
THESIS		02	09	EF650	EF530		TF650L	A/D	TF530L	FX650	A/D	FX530	NF650	NF530	T650	T530	
TREVI		80	87	EF450*	EF450*										T450*	T450*	
VOYAGER		11		EF650	EF500	EF400	TF650L	A/D	TF500L	FX650	A/D	FX500	NF650	NF500	T650	T500	
Y		95	03	EF580	EF400		TF550L	A/D	TF400L	FX550	A/D	FX400	NF550	NF400	T580	T400	
Y10		85	95	EF450		EF330	TF450L	A/D		FX450	A/D		NF450		T450		T330
YPSILON		03	11	EF600	EF400		TF600L	A/D	TF400L	FX600	A/D	FX400	NF600	NF400	T600	T400	
		12		EFB5318L	EFB3518L		TF550L	BC	TF350L	FX550	BC	FX350	NF539	NF359			
ZETA		95	02	EF650	EF500	EF450							NF650	NF500	T650	T500	T450

LAND ROVER

4		04		EF550	EF550	EF400	TF550L	A/D	TF550L	FX550	A/D	FX550	NF550	NF550	T550	T550	T400
88/109		63	86	EF280	EF280										T280	T280	
90/110		83	90	EF330	EF330	EF330									T330	T330	T330
DEFENDER	SUV	90		EF330	EF330	EF330									T330	T330	T330
DEFENDER Van		98		EF330	EF330										T330	T330	
DISCOVERY		89	98	EF450	EF450	EF350	TF450L	A/D	TF450L	FX450	A/D	FX450	NF450	NF450	T450	T450	T350
		98	04	EF521	EF521	EX354											
		05		HF550	HF550		TF550L	A/D	TF550L	FX550	A/D	FX550	NF550	NF550			T400
DISCOVERY SPORT		15		HF650	HF500	EX305	TF650L	A/D	TF500L	FX650	A/D	FX500	NF650	NF500			
FREELANDER		98	06	EF550	EF530	EX354	TF550L	A/D	TF530L	FX550	A/D	FX530	NF550	NF530	T550	T530	
		06		EFB6017L	EFB5017L	EF350	TF600L	BC	TF500L	FX600	BC	FX500	NF607	NF507			T350
RANGE ROVER		70	94	EF450	EF450	EF450	TF450L	A/D	TF450L	FX450	A/D	FX450	NF450	NF450	T450	T450	T450
		94	02	EF550	EF550	EF480	TF550L	A/D	TF550L	FX550	A/D	FX550	NF550	NF550	T550	T550	T480
		02	12	EF641	EF641	EF450											T450
		12		HF600	HF500	EF450	TF600L	A/D	TF500L	FX600	A/D	FX500	NF600	NF500			T450
RANGE ROVER EVOQUE		12		EFB6018L	EFB5318L		TF550L	BC	TF530L	FX550	BC	FX530	NF539	NF539			
RANGE ROVER SPORT		05	12	HF550	HF550	EF400	TF550L	A/D	TF550L	FX550	A/D	FX550	NF550	NF550			T400



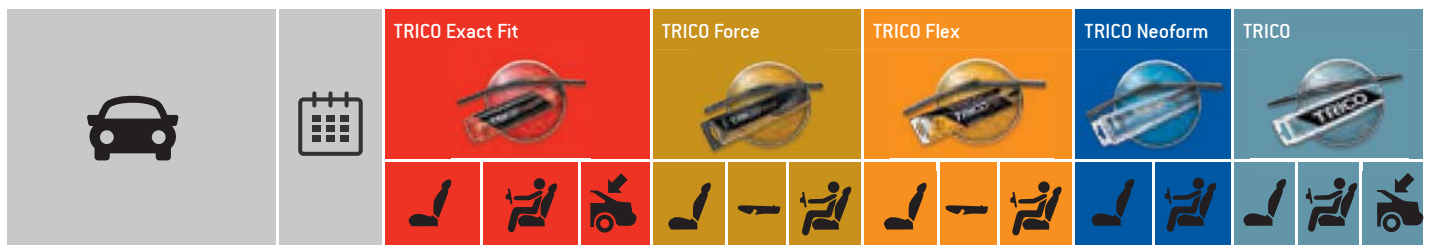

...LAND ROVER																
...RANGE ROVER SPORT	12		HF600	HF500	EF380	TF600L	A/D	TF500L	FX600	A/D	FX500	NF600	NF500	T600	T500	T380
LANDWIND (JMC)																
LANDWIND	05		EF430	EF430		TF430L	A/D	TF430L	FX430	A/D	FX430	NF430	NF430	T430	T430	
LDV																
200	89	96	EF380	EF380		TF350L	A/D	TF350L	FX350	A/D	FX350	NF350	NF350	T380	T380	
400	86	96	EF500	EF500		TF500L	A/D	TF500L	FX500	A/D	FX500	NF500	NF500	T500	T500	
CONVOY	96	09	EF500	EF500		TF500L	A/D	TF500L	FX500	A/D	FX500	NF500	NF500	T500	T500	
CUB	98	01	EF600	EF600		TF600L	A/D	TF600L	FX600	A/D	FX600	NF600	NF600	T600	T600	
MAXUS	05	08	EF550	EF550		TF550L	A/D	TF550L	FX550	A/D	FX550	NF550	NF550	T550	T550	
PILOT	96	05	EF380	EF380		TF350L	A/D	TF350L	FX350	A/D	FX350	NF350	NF350	T380	T380	
SHERPA	74	89	EF380	EF380		TF350L	A/D	TF350L	FX350	A/D	FX350	NF350	NF350	T380	T380	
LEXUS																
CT	10		HF600	HF450		TF600L	A/D	TF450L	FX600	A/D	FX450	NF600	NF450	T600	T450	
ES	96	08	EF600	EF500		TF600L	A/D	TF500L	FX600	A/D	FX500	NF600	NF500	T600	T500	
GS	93	97	EF530	EF480		TF530L	A/D	TF480L	FX530	A/D	FX480	NF530	NF480	T530	T480	
		97	05	EF600	EF500		TF600L	A/D	TF500L	FX600	A/D	FX500	NF600	NF500	T600	T500
		05	11	HF600	HF480		TF600L	A/D	TF480L	FX600	A/D	FX480	NF600	NF480	T600	T480
		12		HF650	HF450		TF650L	A/D	TF450L	FX650	A/D	FX450	NF650	NF450	T650	T450
IS		99	05	EF550	EF480		TF550L	A/D	TF480L	FX550	A/D	FX480	NF550	NF480	T550	T480
		05	12	HF550	HF500		TF550L	A/D	TF500L	FX550	A/D	FX500	NF550	NF500	T550	T500
		13		HF600	HF450		TF600L	A/D	TF450L	FX600	A/D	FX450	NF600	NF450	T600	T450
		01	05	EF550	EF480	EX350	TF550L	A/D	TF480L	FX550	A/D	FX480	NF550	NF480	T550	T480
		09		HF550	HF500		TF550L	A/D	TF500L	FX550	A/D	FX500	NF550	NF500	T550	T500
LS	89	06	EF600	EF400		TF600L	A/D	TF400L	FX600	A/D	FX400	NF600	NF400	T600	T400	
		06		HF600	HF430		TF600L	A/D	TF430L	FX600	A/D	FX430	NF600	NF430	T600	T430
NX	14				EX305											
RC	14		HF600	HF450		TF600L	A/D	TF450L	FX600	A/D	FX450	NF600	NF450	T600	T450	
RX	00	03	EF600	EF530	EX350	TF600L	A/D	TF530L	FX600	A/D	FX530	NF600	NF530	T600	T530	
		03	08	EF650	EF500	EX350	TF650L	A/D	TF500L	FX650	A/D	FX500	NF650	NF500	T650	T500
		08	12	HF650	HF500	EX350	TF650L	A/D	TF500L	FX650	A/D	FX500	NF650	NF500	T650	T500
		12		HF650	HF550	EX402	TF650L	A/D	TF550L	FX650	A/D	FX550	NF650	NF550	T650	T550
SC	01	10	EF600	EF500		TF600L	A/D	TF500L	FX600	A/D	FX500	NF600	NF500	T600	T500	
LIGIER																
AMBRA	96		EF600		EX180	TF600L	A/D		FX600	A/D		NF600		T600		
BE UP	02		EF600		EX180	TF600L	A/D		FX600	A/D		NF600		T600		
NOVA	02		EF600			TF600L	A/D		FX600	A/D		NF600		T600		
LINCOLN																
AVIATOR	02		EF550	EF550	EF400	TF550L	A/D	TF550L	FX550	A/D	FX550	NF550	NF550	T550	T550	T400
BLACKWOOD	00	05	EF500	EF500		TF500L	A/D	TF500L	FX500	A/D	FX500	NF500	NF500	T500	T500	
CONTINENTAL	98		EF600	EF500		TF600L	A/D	TF500L	FX600	A/D	FX500	NF600	NF500	T600	T500	
CONTINENTAL TOWN CAR	88		EF500	EF500		TF500L	A/D	TF500L	FX500	A/D	FX500	NF500	NF500	T500	T500	
LS	98		EF600	EF480		TF600L	A/D	TF480L	FX600	A/D	FX480	NF600	NF480	T600	T480	
MARK LT	05		EF500	EF500		TF500L	A/D	TF500L	FX500	A/D	FX500	NF500	NF500	T500	T500	
NAVIGATOR	97	02	EF500	EF500	EF500	TF500L	A/D	TF500L	FX500	A/D	FX500	NF500	NF500	T500	T500	T500
ZEPHYR/MKZ	04		EF600	EF480		TF600L	A/D	TF480L	FX600	A/D	FX480	NF600	NF480	T600	T480	





LOTUS

ELAN	89	95	EF550	EF550		TF550L	A/D	TF550L	FX550	A/D	FX550	NF550	NF550	T550	T550
EUROPA	66	76	EF400	EF400		TF400L	A/D	TF400L	FX400	A/D	FX400	NF400	NF400	T400	T400

MASERATI

228	86	90	EF500	EF500		TF500L	A/D	TF500L	FX500	A/D	FX500	NF500	NF500	T500	T500	
3200 GT	98	02	EF550	EF550		TF550L	A/D	TF550L	FX550	A/D	FX550	NF550	NF550	T550	T550	
BITURBO		84	94	EF500	EF500		TF500L	A/D	TF500L	FX500	A/D	FX500	NF500	NF500	T500	T500
		81	93	EF500	EF500		TF500L	A/D	TF500L	FX500	A/D	FX500	NF500	NF500	T500	T500
		85	94	EF500	EF500		TF500L	A/D	TF500L	FX500	A/D	FX500	NF500	NF500	T500	T500
BORA	71	80	EF450	EF450		TF450L	A/D	TF450L	FX450	A/D	FX450	NF450	NF450	T450	T450	
GHIBLI		67		EF500	EF500		TF500L	A/D	TF500L	FX500	A/D	FX500	NF500	NF500	T500	T500
		68	73	EF500	EF500										T500	T500
		13		EFB6518L	EFB4818L		TF650L	BC	TF480L	FX650	BC	FX480	NF659	NF489		
GRAN TURISMO	08		EF650	EF400		TF650L	A/D	TF400L	FX650	A/D	FX400	NF650	NF400	T650	T400	
KHAMSIN	74	82	EF450	EF450		TF450L	A/D	TF450L	FX450	A/D	FX450	NF450	NF450	T450	T450	
KYALAMI	76	85	EF450	EF450		TF450L	A/D	TF450L	FX450	A/D	FX450	NF450	NF450	T450	T450	
MERAK	75	83	EF450	EF450		TF450L	A/D	TF450L	FX450	A/D	FX450	NF450	NF450	T450	T450	
QUATTROPORTE		76	00	EF500	EF500		TF500L	A/D	TF500L	FX500	A/D	FX500	NF500	NF500	T500	T500
		13		EFB6518L	EFB4818L		TF650L	BC	TF480L	FX650	BC	FX480	NF659	NF489		
SHAMAL	89	95	EF500	EF500		TF500L	A/D	TF500L	FX500	A/D	FX500	NF500	NF500	T500	T500	
SPYDER	88	96	EF500	EF500		TF500L	A/D	TF500L	FX500	A/D	FX500	NF500	NF500	T500	T500	

MAZDA

2		03	06	EF600	EF400	EX351	TF600L	A/D	TF400L	FX600	A/D	FX400	NF600	NF400	T600	T400	
		07	14	EF600	EF350	EX351	TF600L	A/D	TF350L	FX600	A/D	FX350	NF600	NF350	T600	T350	
		15		HF550	HF430	EX351	TF550L	A/D	TF430L	FX550	A/D	FX430	NF550	NF430			
3		03	08	EFB536	EFB456		TF530L	BC	TF450L	FX530	BC	FX450	NF536	NF456			
		09	13	HF600	HF480		TF600L	A/D	TF480L	FX600	A/D	FX480	NF600	NF480	T600	T480	
		13		HF600	HF450		TF600L	A/D	TF450L	FX600	A/D	FX450	NF600	NF450	T600	T450	
		03	08	EFB536	EFB456	EX357	TF530L	BC	TF450L	FX530	BC+E	FX450	NF536	NF456			
		09	13	HF600	HF480	EX350	TF600L	A/D	TF480L	FX600	A/D	FX480	NF600	NF480	T600	T480	
		13		HF600	HF450	EX305	TF600L	A/D	TF450L	FX600	A/D	FX450	NF600	NF450	T600	T450	
5		05		EF650	EF400	EX305	TF650L	A/D	TF400L	FX650	A/D	FX400	NF650	NF400	T650	T400	
6		02	07	EF550	EF450		TF550L	A/D	TF450L	FX550	A/D	FX450	NF550	NF450	T550	T450	
		08	12	HF600	HF400		TF600L	A/D	TF400L	FX600	A/D	FX400	NF600	NF400	T600	T400	
		12		HF600	HF450		TF600L	A/D	TF450L	FX600	A/D	FX450	NF600	NF450	T600	T450	
		02	07	EF550	EF450	EF500	TF550L	A/D	TF450L	FX550	A/D	FX450	NF550	NF450	T550	T450	T500
		08	12	HF600	HF400	HF500	TF600L	A/D	TF400L	FX600	A/D	FX400	NF600	NF400	T600	T400	
		02	07	EF550	EF450	EX305	TF550L	A/D	TF450L	FX550	A/D	FX450	NF550	NF450	T550	T450	
		08	12	HF600	HF400	EX350	TF600L	A/D	TF400L	FX600	A/D	FX400	NF600	NF400	T600	T400	
		12		HF600	HF450	EX305	TF600L	A/D	TF450L	FX600	A/D	FX450	NF600	NF450	T600	T450	
121		90	97	EF500	EF400		TF500L	A/D	TF400L	FX500	A/D	FX400	NF500	NF400	T500	T400	
		87	90	EF450	EF450	EF380	TF450L	A/D	TF450L	FX450	A/D	FX450	NF450	NF450	T450	T450	T380
		96	03	EF480	EF480		TF480L	A/D	TF480L	FX480	A/D	FX480	NF480	NF480	T480	T480	
323		80	89	EF430*	EF430*	EF380*									T430*	T430*	T380*
		85	91	EF450	EF450		TF450L	A/D	TF450L	FX450	A/D	FX450	NF450	NF450	T450	T450	
		89	94	EF530	EF450		TF530L	A/D	TF450L	FX530	A/D	FX450	NF530	NF450	T530	T450	
		94	04	EF530	EF480		TF530L	A/D	TF480L	FX530	A/D	FX480	NF530	NF480	T530	T480	

TRICO Exact Fit TRICO Force TRICO Flex TRICO Neoform TRICO

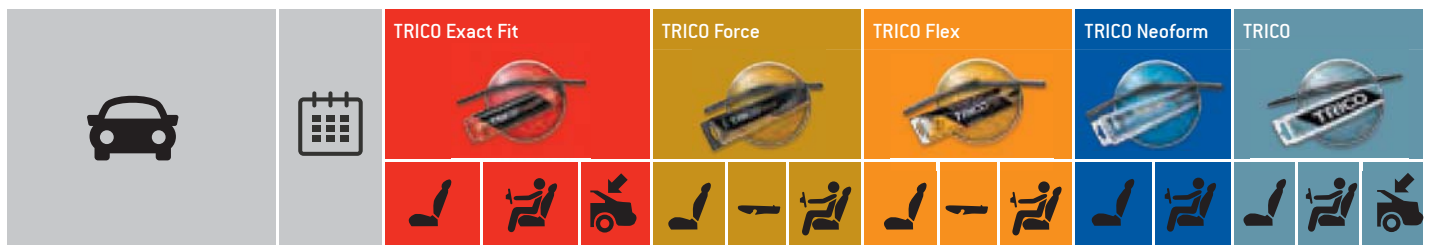

...MAZDA

...323		80	89	EF430*	EF430*											T430*	T430*	
		85	93	EF450	EF450	EF400	TF450L	A/D	TF450L	FX450	A/D	FX450	NF450	NF450	T450	T450	T400	
		98	04	EF530	EF480	EF500	TF530L	A/D	TF480L	FX530	A/D	FX480	NF530	NF480	T530	T480	T500	
		78	86	EF380	EF380	EF330	TF350L	A/D	TF350L	FX350	A/D	FX350	NF350	NF350	T380	T380	T330	
		86	98	EF450	EF450	EF350	TF450L	A/D	TF450L	FX450	A/D	FX450	NF450	NF450	T450	T450	T350	
		94	98	EF530	EF480	EF500	TF530L	A/D	TF480L	FX530	A/D	FX480	NF530	NF480	T530	T480	T500	
616		73	78	EF380	EF380		TF350L	A/D	TF350L	FX350	A/D	FX350	NF350	NF350	T380	T380		
626		79	82	EF430*	EF430*											T430*	T430*	
		82	87	EF450*	EF450*											T450*	T450*	
		87	92	EF480	EF480		TF480L	A/D	TF480L	FX480	A/D	FX480	NF480	NF480	T480	T480		
		92	97	EF530	EF500		TF530L	A/D	TF500L	FX530	A/D	FX500	NF530	NF500	T530	T500		
		97	02	EF530	EF480		TF530L	A/D	TF480L	FX530	A/D	FX480	NF530	NF480	T530	T480		
		83	87	EF450*	EF450*											T450*	T450*	
		87	92	EF480	EF480	EF400	TF480L	A/D	TF480L	FX480	A/D	FX480	NF480	NF480	T480	T480	T400	
		91	97	EF530	EF500		TF530L	A/D	TF500L	FX530	A/D	FX500	NF530	NF500	T530	T500		
		97	02	EF530	EF480	EF530	TF530L	A/D	TF480L	FX530	A/D	FX480	NF530	NF480	T530	T480	T530	
		87	97	EF480	EF480	EF400	TF480L	A/D	TF480L	FX480	A/D	FX480	NF480	NF480	T480	T480	T400	
		98	02	EF530	EF480	EF350	TF530L	A/D	TF480L	FX530	A/D	FX480	NF530	NF480	T530	T480	T350	
		87	92	EF480	EF480		TF480L	A/D	TF480L	FX480	A/D	FX480	NF480	NF480	T480	T480		
818		74	78	EF380	EF380		TF350L	A/D	TF350L	FX350	A/D	FX350	NF350	NF350	T380	T380		
929		79	87	EF430*	EF430*	EF380*										T430*	T430*	T380*
		87	91	EF500	EF500	EF350	TF500L	A/D	TF500L	FX500	A/D	FX500	NF500	NF500	T500	T500	T350	
		83	87	EF450	EF450	EF380*	TF450L	A/D	TF450L	FX450	A/D	FX450	NF450	NF450	T450	T450	T380*	
1000		75	77	EF350	EF350		TF350L	A/D	TF350L	FX350	A/D	FX350	NF350	NF350	T350	T350		
1300		75	77	EF380*	EF380*											T380*	T380*	
B-SERIE		77	82	EF350	EF350		TF350L	A/D	TF350L	FX350	A/D	FX350	NF350	NF350	T350	T350		
		81	85	EF380	EF380		TF350L	A/D	TF350L	FX350	A/D	FX350	NF350	NF350	T380	T380		
		85		EF450	EF450		TF450L	A/D	TF450L	FX450	A/D	FX450	NF450	NF450	T450	T450		
BT-50		06		EF450	EF450		TF450L	A/D	TF450L	FX450	A/D	FX450	NF450	NF450	T450	T450		
CX-3		15		HF600	HF450	EX252	TF600L	A/D	TF450L	FX600	A/D	FX450	NF600	NF450				
CX-5		11		HF600	HF450	EX350	TF600L	A/D	TF450L	FX600	A/D	FX450	NF600	NF450	T600	T450		
CX-7		06		HF650	HF400	EX350	TF650L	A/D	TF400L	FX650	A/D	FX400	NF650	NF400	T650	T400		
DEMIO		96		EF500	EF400	EF400	TF500L	A/D	TF400L	FX500	A/D	FX400	NF500	NF400	T500	T400	T400	
E-SERIE Van		78	84	EF350	EF350		TF350L	A/D	TF350L	FX350	A/D	FX350	NF350	NF350	T350	T350		
FIGHTER		02	06	EF450	EF450		TF450L	A/D	TF450L	FX450	A/D	FX450	NF450	NF450	T450	T450		
MPV		95	99	EF550	EF500	EF430	TF550L	A/D	TF500L	FX550	A/D	FX500	NF550	NF500	T550	T500	T430	
		99	06	EF600	EF600	EF400	TF600L	A/D	TF600L	FX600	A/D	FX600	NF600	NF600	T600	T600	T400	
MX-3		91	02	EF530	EF450		TF530L	A/D	TF450L	FX530	A/D	FX450	NF530	NF450	T530	T450		
MX-5		90		EF450	EF450		TF450L	A/D	TF450L	FX450	A/D	FX450	NF450	NF450	T450	T450		
MX-6		92	97	EF500	EF500		TF500L	A/D	TF500L	FX500	A/D	FX500	NF500	NF500	T500	T500		
PREMACY		99	05	EF600	EF400	EF350	TF600L	A/D	TF400L	FX600	A/D	FX400	NF600	NF400	T600	T400	T350	
RX 5		75	81	EF430*	EF430*											T430*	T430*	
RX 7		79	86	EF430*	EF430*											T430*	T430*	
		85	02	EF500	EF500	EF450	TF500L	A/D	TF500L	FX500	A/D	FX500	NF500	NF500	T500	T500	T450	
		89	91	EF500	EF500		TF500L	A/D	TF500L	FX500	A/D	FX500	NF500	NF500	T500	T500		
RX 8		03	12	EF500	EF450		TF500L	A/D	TF450L	FX500	A/D	FX450	NF500	NF450	T500	T450		



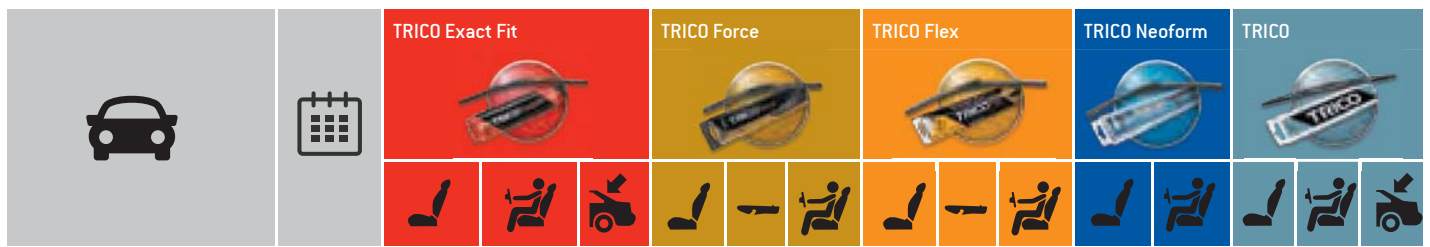

...MAZDA

TRIBUTE	00	08	EF500	EF480	EF280	TF500L	A/D	TF480L	FX500	A/D	FX480	NF500	NF480	T500	T480	T280
XEDOS 6	92	99	EF530	EF500		TF530L	A/D	TF500L	FX530	A/D	FX500	NF530	NF500	T530	T500	
XEDOS 9	93	02	EF530	EF500		TF530L	A/D	TF500L	FX530	A/D	FX500	NF530	NF500	T530	T500	

MERCEDES-BENZ

/8	68	77	EF400	EF400		TF400L	A/D	TF400L	FX400	A/D	FX400	NF400	NF400	T400	T400	
100	88	96	EF500	EF500		TF500L	A/D	TF500L	FX500	A/D	FX500	NF500	NF500	T500	T500	
190	82	87	EF580									NF550				
190	88	93	EF600									NF600				
A-CLASS	97	04	EF650	EF600	EF350	TF650L	A/D	TF600R	FX650	A/D	FX600	NF650	NF600	T650	T600	T350
	04	12	EFB6517L	EFB6017R	EX300	TF650L	BC	TF600R	FX650	BC	FX600	NF657	NF607			
	12	15	EFB6017L	EFB4817L	EX255	TF600L	BC	TF480L	FX600	BC	FX480	NF607	NF487			
B-CLASS	05	11	EFB6517L	EFB5517R	EX282	TF650L	BC	TF550R	FX650	BC	FX550	NF657	NF557			
	12		EFB6017L	EFB4817L	EX254	TF600L	BC	TF480L	FX600	BC	FX480	NF607	NF487			
C-CLASS	93	00	EF600									NF600				
	00	03	EF600	EF550		TF600L	A/D	TF550L	FX600	A/D	FX550	NF600	NF550	T600	T550	
	03	07	EFB555	EFB555								NF555	NF555			
	07	08	EFB6018L	EFB6018L		TF600L	BC	TF600L	FX600	BC	FX600	NF6016	NF6016			
	08	13	EFB606	EFB606		TF600L	BC	TF600L				NF606	NF606			
	96	01	EF600		EF400							NF600				T400
	01	03	EF600	EF550	EF400	TF600L	A/D	TF550L	FX600	A/D	FX550	NF600	NF550	T600	T550	T400
	03	07	EFB555	EFB555	EF400							NF555	NF555			T400
	07	08	EFB6018L	EFB6018L	EX300	TF600L	BC	TF600L	FX600	BC	FX600	NF6016	NF6016			
	08	13	EFB606	EFB606	EX300	TF600L	BC	TF600L				NF606	NF606			
	14				EX255											
	01	03	EF600	EF550		TF600L	A/D	TF550L	FX600	A/D	FX550	NF600	NF550	T600	T550	
	03	08	EFB555	EFB555								NF555	NF555			
	11	13	EFB606	EFB606		TF600L	BC	TF600L				NF606	NF606			
CITAN	12		EFB5514L	EFB5014L		TF550L	F	TF500L	FX550	E1	FX500	NF5514	NF4514			
CLA	13		EFB6017L	EFB4817L		TF600L	BC	TF480L	FX600	BC	FX480	NF607	NF487			
	13		EFB6017L	EFB4817L	EX307	TF600L	BC	TF480L	FX600	BC	FX480	NF607	NF487			
CLC-CLASS	08	11	EFB555	EFB555								NF555	NF555			
CLK	97	02	EF600									NF600				
	02	09	EFB555	EFB555								NF555	NF555			
	98	02	EF600									NF600				
	02	10	EFB555	EFB555								NF555	NF555			
CLS	04	10	EFB656	EFB656		TF650L	BC	TF650L	FX650	BC+E	FX650	NF656	NF656			
	11	14	EFB606	EFB606		TF600L	BC	TF600L				NF606	NF606			
	15		EFB6018L	EFB6018L		TF600L	BC	TF600L	FX600	BC	FX600	NF609	NF609			
	12	14	EFB606	EFB606	EX358	TF600L	BC	TF600L				NF606	NF606			
	15		EFB6018L	EFB6018L	EX358	TF600L	BC	TF600L	FX600	BC	FX600	NF609	NF609			
COUPE	77	85	EF500	EF500		TF500L	A/D	TF500L	FX500	A/D	FX500	NF500	NF500	T500	T500	
	87	87	EF580									NF550				
	87	93	EF600									NF600				
	88	93	EF600													
E-CLASS	76	85	EF500	EF500		TF500L	A/D	TF500L	FX500	A/D	FX500	NF500	NF500	T500	T500	
	84	87	EF580									NF550				



		TRICO Exact Fit			TRICO Force			TRICO Flex			TRICO Neoform		TRICO		

...MERCEDES-BENZ

...E-CLASS	88	02	EF600									NF600				
	02	08	EFB656	EFB656		TF650L	BC	TF650L				NF656	NF656			
	09	13	EFB606	EFB606		TF600L	BC	TF600L				NF606	NF606			
	14		EFB6018L	EFB6018L		TF600L	BC	TF600L	FX600	BC	FX600	NF609	NF609			
	77	85	EF500	EF500	EF400	TF500L	A/D	TF500L	FX500	A/D	FX500	NF500	NF500	T500	T500	T400
	85	87	EF580		EF450							NF550				T450
	88	93	EF600		EF450							NF600				T450
	92	03	EF600		EF400							NF600				T400
	03	09	EFB656	EFB656	EF400	TF650L	BC	TF650L				NF656	NF656			T400
	09	13	EFB606	EFB606	EX300	TF600L	BC	TF600L				NF606	NF606			
	14		EFB6018L	EFB6018L	EX300	TF600L	BC	TF600L	FX600	BC	FX600	NF609	NF609			
	93	97	EF600									NF600				
	09	13	EFB606	EFB606		TF600L	BC	TF600L				NF606	NF606			
	14		EFB6018L	EFB6018L		TF600L	BC	TF600L	FX600	BC	FX600	NF609	NF609			
	93	98	EF600									NF600				
	10	13	EFB606	EFB606		TF600L	BC	TF600L				NF606	NF606			
	14		EFB6018L	EFB6018L		TF600L	BC	TF600L	FX600	BC	FX600	NF609	NF609			
G-CLASS	79		EF400	EF400	EF380	TF400L	A/D	TF400L	FX400	A/D	FX400	NF400	NF400	T400	T400	T380
GL-CLASS	06	11	EFB7017L	EFB5317L	EX300	TF700L	BC	TF530L	FX700	BC	FX530	NF707	NF537			
	12		EFB6518L	EFB5318L	EX300	TF650L	BC	TF550L	FX650	BC	FX550	NF659	NF539			
GLA	14		EFB6017L	EFB4817L		TF600L	BC	TF480L	FX600	BC	FX480	NF607	NF487			
GLK-CLASS	08	14	EFB556	EFB486	EX300	TF550L	BC	TF480L	FX550	BC+E	FX480	NF556	NF486			
	15		EFB5318L	EFB4818L	EX300		BC	TF480L	FX550	BC	FX480	NF557	NF489			
M-CLASS	98	05	EF550	EF550	EF400	TF550L	A/D	TF550L	FX550	A/D	FX550	NF550	NF550	T550	T550	T400
	05	11	EFB7017L	EFB5317L	EX300	TF700L	BC	TF530L	FX700	BC	FX530	NF707	NF537			
	12		EFB6518L	EFB5318L	EX300	TF650L	BC	TF550L	FX650	BC	FX550	NF659	NF539			
R-CLASS	06		EFB7017L	EFB5317L	EX300	TF700L	BC	TF530L	FX700	BC	FX530	NF707	NF537			
S-CLASS	72	80	EF450	EF400		TF450L	A/D	TF400L	FX450	A/D	FX400	NF450	NF400	T450	T400	
	79	91	EF530	EF530		TF530L	A/D	TF530L	FX530	A/D	FX530	NF530	NF530	T530	T530	
	91	98	EF600									NF600				
	00	13	EFB656	EFB656		TF650L	BC	TF650L	FX650	BC+E	FX650	NF656	NF656			
	14		EFB6517L	EFB5517L		TF600L	BC	TF550L	FX600	BC	FX550	NF607	NF557			
	81	91	EF530	EF530		TF530L	A/D	TF530L	FX530	A/D	FX530	NF530	NF530	T530	T530	
	92	99	EF600									NF600				
	00	13	EFB656	EFB656		TF650L	BC	TF650L	FX650	BC+E	FX650	NF656	NF656			
	14		EFB6517L	EFB5517L		TF600L	BC	TF550L	FX600	BC	FX550	NF607	NF557			
SL	72	81	EF450	EF450		TF450L	A/D	TF450L	FX450	A/D	FX450	NF450	NF450	T450	T450	
	71	89	EF450	EF450		TF450L	A/D	TF450L	FX450	A/D	FX450	NF450	NF450	T450	T450	
	89	01	EF600									NF600				
	01	12	EFB656	EFB656		TF650L	A/D	TF650L	FX650	A/D	FX650	NF656	NF656			
SLK	96	04	EF550	EF550		TF550L	A/D	TF550L	FX550	A/D	FX550	NF550	NF550	T550	T550	
	04	11	EFB5517L	EFB5517L		TF550L	BC	TF550L	FX550	BC	FX550	NF557	NF557			
	11		EFB5517L	EFB5517L		TF550L	BC	TF550L	FX550	BC	FX550	NF557	NF557			
SLR	04	10	EFB656	EFB656		TF650L	BC	TF650L	FX650	BC+E	FX650	NF656	NF656			
SLS	10		EFB506	EFB506		TF500L	BC	TF500L	FX500	BC+E	FX500	NF506	NF506			
SPRINTER	96	06	EF600	EF550		TF600L	A/D	TF550L	FX600	A/D	FX550	NF600	NF550	T600	T550	

			TRICO Exact Fit			TRICO Force			TRICO Flex			TRICO Neoform		TRICO		
--	--	--	-----------------	--	--	-------------	--	--	------------	--	--	---------------	--	-------	--	--



...MERCEDES-BENZ

...SPRINTER	06		EFB6517L	EFB6017L		TF650L	BC	TF600L	FX650	BC	FX600	NF657	NF607			
SPRINTER 2-t	95	06	EF600	EF550		TF600L	A/D	TF550L	FX600	A/D	FX550	NF600	NF550	T600	T550	
SPRINTER 3-t	95	06	EF600	EF550		TF600L	A/D	TF550L	FX600	A/D	FX550	NF600	NF550	T600	T550	
T1	77	96	EF500	EF500		TF500L	A/D	TF500L	FX500	A/D	FX500	NF500	NF500	T500	T500	
T1/TN	81	95	EF500	EF500		TF500L	A/D	TF500L	FX500	A/D	FX500	NF500	NF500	T500	T500	
VANEO	02	04	EF650	EF600	EF380	TF650L	A/D	TF600L	FX650	A/D	FX600	NF650	NF600	T650	T600	
		04	05	EFB6517L	EFB6017L	EF380	TF650L	BC	TF600L	FX650	BC	FX600	NF657	NF607		
V-CLASS	96	03	EF653	EF553	EF450											T450
		15			EX405											
VIANO	03	05	EF703	EF653	EF350											T350
		05	14	EFB7017L	EFB6517R	EF350	TF700L	BC	TF650R	FX700	BC	FX650	NF707	NF657		T350
VITO / MIXTO	03	04	EF703	EF653												
VITO	05	14	EFB7017L	EFB6517R	EF450	TF700L	BC	TF650R	FX700	BC	FX650	NF707	NF657			T450
		15			EX405											

MERCURY

GRAND MARQUIS	91	99	EF550	EF550		TF550L	A/D	TF550L	FX550	A/D	FX550	NF550	NF550	T550	T550	
MARINER	04	07	EF500	EF450	EF280	TF500L	A/D	TF450L	FX500	A/D	FX450	NF500	NF450	T500	T450	T280
MONTEGO	03		EFB606	EFB506		TF600L	A/D	TF500L	FX600	A/D	FX500	NF606	NF506			
MOUNTAINEER	00	01	EF450	EF450	EF350	TF450L	A/D	TF450L	FX450	A/D	FX450	NF450	NF450	T450	T450	T350
		00		EF500	EF400	TF500L	A/D	TF450L	FX500	A/D	FX450	NF500	NF450	T500	T500	T400
MYSTIQUE	94	01	EF530	EF500		TF530L	A/D	TF500L	FX530	A/D	FX500	NF530	NF500	T530	T500	

MG

1300 Mk.II	67	70	EF280	EF280										T280	T280		
MAESTRO	83	90	EF500	EF500	EF500	TF500L	A/D	TF500L	FX500	A/D	FX500	NF500	NF500	T500	T500	T500	
METRO	82	90	EF400	EF400	EF350	TF400L	A/D	TF400L	FX400	A/D	FX400	NF400	NF400	T400	T400	T350	
MG 6	10		EFB6017L	EFB4517L		TF600L	BC	TF450L	FX600	BC	FX450	NF607	NF459				
MGB	66	80	EF280	EF280										T280	T280		
MGB GT	66	80	EF280	EF280										T280	T280		
MGC	67	69	EF280	EF280										T280	T280		
MGC GT	67	69	EF280	EF280										T280	T280		
MGF	95	02	EF500	EF500		TF500L	A/D	TF500L	FX500	A/D	FX500	NF500	NF500	T500	T500		
MGR V8	92	95	EF280	EF280										T280	T280		
MG TF	02	05	EF500	EF500		TF500L	A/D	TF500L	FX500	A/D	FX500	NF500	NF500	T500	T500		
MG X-POWER	03	08	EF530	EF530		TF530L	A/D	TF530L	FX530	A/D	FX530	NF530	NF530	T530	T530		
MG ZR	01	05	EF450	EF450	EF450	TF450L	A/D	TF450L	FX450	A/D	FX450	NF450	NF450	T450	T450	T450	
MG ZS		01	05	EF500	EF450		TF500L	A/D	TF450L	FX500	A/D	FX450	NF500	NF450	T500	T450	
		01	05	EF500	EF450	EF450	TF500L	A/D	TF450L	FX500	A/D	FX450	NF500	NF450	T500	T450	T450
MG ZT	01	05	EF550	EF550		TF550L	A/D	TF550L	FX550	A/D	FX550	NF550	NF550	T550	T550		
MG ZT-T	01	05	EF550	EF550	EX357	TF550L	A/D	TF550L	FX550	A/D	FX550	NF550	NF550	T550	T550		
MIDGET	64	79	EF280	EF280										T280	T280		
MONTEGO	84	90	EF500	EF500		TF500L	A/D	TF500L	FX500	A/D	FX500	NF500	NF500	T500	T500		

MINI

MINI		01	04	EF450	EF480	EX303	TF450L	A/D	TF480L	FX450	A/D	FX480	NF450	NF480	T450	T480
		04	06	EF450	EF480	EX282	TF450L	A/D	TF480L	FX450	A/D	FX480	NF450	NF480	T450	T480
		07	12	EF450	EF480	EX254	TF450L	A/D	TF480L	FX450	A/D	FX480	NF450	NF480	T450	T480
		12	13	EFB4514L	EFB4514L	EX254	TF450L	F	TF450L	FX450	E1	FX450	NF4514	NF4514		



		TRICO Exact Fit			TRICO Force			TRICO Flex			TRICO Neoform		TRICO	

...MINI

...MINI		14		HF450	HF480	EX254	TF450L	A/D	TF480L	FX450	A/D	FX480	NF450	NF480	T450	T480
		11		EFB5017L	EFB5317L		TF500L	BC	TF530L	FX500	BC	FX530	NF507	NF537		
		11		EFB5017L	EFB5317L		TF500L	BC	TF530L	FX500	BC	FX530	NF507	NF537		
		04	12	EF450	EF480		TF450L	A/D	TF480L	FX450	A/D	FX480	NF450	NF480	T450	T480
		12		EFB4514L	EFB4514L		TF450L	F	TF450L	FX450	E1	FX450	NF4514	NF4514		
MINI CLUBMAN		07	12	EF450	EF480	EX307x2	TF450L	A/D	TF480L	FX450	A/D	FX480	NF450	NF480	T450	T480
		12		EFB4514L	EFB4514L	EX307x2	TF450L	F	TF450L	FX450	E1	FX450	NF4514	NF4514		
MINI COUNTRYMAN		10		EFB4817L	EFB5017L	EX254	TF480L	BC	TF500L	FX480	BC	FX500	NF487	NF507		
MINI PACEMAN		12		EFB4817L	EFB5017L	EX253	TF480L	BC	TF500L	FX480	BC	FX500	NF487	NF507		

mitsubishi

3000 GT		92	99	EF530	EF500		TF530L	A/D	TF500L	FX530	A/D	FX500	NF530	NF500	T530	T500
AIRTREK		02	06	EF550	EF450	EX306	TF550L	A/D	TF450L	FX550	A/D	FX450	NF550	NF450	T550	T450
ASX		10		HF600	HF530	EX252	TF600L	A/D	TF530L	FX600	A/D	FX530	NF600	NF530		
ASX Van		10		HF600	HF530	EX252	TF600L	A/D	TF530L	FX600	A/D	FX530	NF600	NF530		
ATTRAGE		15		EF550	EF350		TF550L	A/D	TF350L	FX550	A/D	FX350	NF550	NF350	T550	T350
CANTER		92		EF550	EF550		TF550L	A/D	TF550L	FX550	A/D	FX550	NF550	NF550	T550	T550
CARISMA		96	06	EF530	EF500		TF530L	A/D	TF500L	FX530	A/D	FX500	NF530	NF500	T530	T500
		95	06	EF530	EF500	EF550	TF530L	A/D	TF500L	FX530	A/D	FX500	NF530	NF500	T530	T500
CHALLENGER		97	05	EF500	EF500	EF430	TF500L	A/D	TF500L	FX500	A/D	FX500	NF500	NF500	T500	T430
COLT		78	84	EF400*	EF400*	EF350									T400*	T350
		78	84	EF450*	EF450*										T450*	T450*
		92	96	EF500	EF430	EF380	TF500L	A/D	TF430L	FX500	A/D	FX430	NF500	NF430	T500	T380
		95	03	EF530	EF480	EF280	TF530L	A/D	TF480L	FX530	A/D	FX480	NF530	NF480	T530	T280
		04	12	EF650	EF280	EX357									T650	T280
COLT CZC		06	09	EF650	EF280										T650	T280
COLT LANCER		78	79	EF400*	EF400*										T400*	T400*
		78	79	EF400*	EF400*										T400*	T400*
CORDIA		82	89	EF450*	EF450*										T450*	T450*
DIAMANTE		90	96	EF550	EF500		TF550L	A/D	TF500L	FX550	A/D	FX500	NF550	NF500	T550	T500
		92	98	EF550	EF500		TF550L	A/D	TF500L	FX550	A/D	FX500	NF550	NF500	T550	T500
ECLIPSE		89	95	EF500	EF500		TF500L	A/D	TF500L	FX500	A/D	FX500	NF500	NF500	T500	T500
		95	99	EF600	EF550		TF600L	A/D	TF550L	FX600	A/D	FX550	NF600	NF550	T600	T550
		89	94	EF500	EF500		TF500L	A/D	TF500L	FX500	A/D	FX500	NF500	NF500	T500	T500
		95	05	EF600	EF550		TF600L	A/D	TF550L	FX600	A/D	FX550	NF600	NF550	T600	T550
ENDEAVOR		03	11	EF650	EF530		TF650L	A/D	TF530L	FX650	A/D	FX530	NF650	NF530	T650	T530
GALANT		80	90	EF430*	EF430*										T430*	T430*
		87	93	EF480	EF450		TF480L	A/D	TF450L	FX480	A/D	FX450	NF480	NF450	T480	T450
		92	96	EF550	EF480		TF550L	A/D	TF480L	FX550	A/D	FX480	NF550	NF480	T550	T480
		96	04	EF550	EF450		TF550L	A/D	TF450L	FX550	A/D	FX450	NF550	NF450	T550	T450
		03		EF550	EF450		TF550L	A/D	TF450L	FX550	A/D	FX450	NF550	NF450	T550	T450
		88	92	EF480	EF450	EF500	TF480L	A/D	TF450L	FX480	A/D	FX450	NF480	NF450	T480	T500
		92	96	EF550	EF480	EF500	TF550L	A/D	TF480L	FX550	A/D	FX480	NF550	NF480	T550	T500
		80	84	EF430*	EF430*	EF380*									T430*	T380*
		96	03	EF550	EF450	EF400	TF550L	A/D	TF450L	FX550	A/D	FX450	NF550	NF450	T550	T400
GALLOPER		98	03	EF430	EF430	EF350	TF430L	A/D	TF430L	FX430	A/D	FX430	NF430	NF430	T430	T350
GRANDIS		04		TX700	EF530	EX306										

			TRICO Exact Fit			TRICO Force			TRICO Flex			TRICO Neoform		TRICO	
--	--	--	------------------------	--	--	--------------------	--	--	-------------------	--	--	----------------------	--	--------------	--



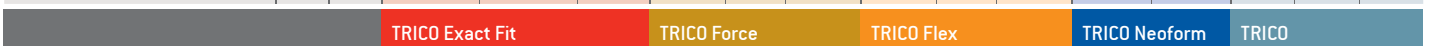

...MITSUBISHI

i	06		HF700		EX306	TF700L	A/D		FX700	A/D		NF700						
i-Miev	09		HF700		EX306	TF700L	A/D		FX700	A/D		NF700						
L 200	Pickup	86	96	EF400	EF400			TF400L	A/D	TF400L	FX400	A/D	FX400	NF400	NF400	T400	T400	
		96	06	EF480	EF480			TF480L	A/D	TF480L	FX480	A/D	FX480	NF480	NF480	T480	T480	
		07		EF550	EF480			TF550L	A/D	TF480L	FX550	A/D	FX480	NF550	NF480	T550	T480	
L 200 Van		86	96	EF400	EF400			TF400L	A/D	TF400L	FX400	A/D	FX400	NF400	NF400	T400	T400	
		96	06	EF480	EF480			TF480L	A/D	TF480L	FX480	A/D	FX480	NF480	NF480	T480	T480	
		07		EF550	EF480			TF550L	A/D	TF480L	FX550	A/D	FX480	NF550	NF480	T550	T480	
L 300		80		EF450	EF450			TF450L	A/D	TF450L	FX450	A/D	FX450	NF450	NF450	T450	T450	
L 400		96	05	EF651	EF651	EF430											T430	
L 400 / SPACE GEAR	MPV	95	05	EF651	EF651	EF430											T430	
LANCER		79	83	EF430*	EF430*											T430*	T430*	
		83	88	EF450*	EF450*											T450*	T450*	
		88	90	EF500*	EF450*											T500*	T450*	
		90	05	EF500	EF430			TF500L	A/D	TF430L	FX500	A/D	FX430	NF500	NF430	T500	T430	
		06		EF600	EF450			TF600L	A/D	TF450L	FX600	A/D	FX450	NF600	NF450	T600	T450	
		88	94	EF500*	EF450*	EF450										T500*	T450*	T450
		85	92	EF450*	EF450*	EF350										T450*	T450*	T350
		92	03	EF500	EF430	EF400		TF500L	A/D	TF430L	FX500	A/D	FX430	NF500	NF430	T500	T430	T400
		03	08	EF600	EF450	EX351		TF600L	A/D	TF450L	FX600	A/D	FX450	NF600	NF450	T600	T450	
		92	04	EF500	EF430			TF500L	A/D	TF430L	FX500	A/D	FX430	NF500	NF430	T500	T430	
LANCER SPORTBACK		07		EF600	EF450	EX351		TF600L	A/D	TF450L	FX600	A/D	FX450	NF600	NF450	T600	T450	
MIRAGE		12		EF550	EF530	EX305		TF550L	A/D	TF530L	FX550	A/D	FX530	NF550	NF530	T550	T530	
MONTERO		83	91	EF400	EF400	EF380*		TF400L	A/D	TF400L	FX400	A/D	FX400	NF400	NF400	T400	T400	T380*
		90	99	EF480	EF480	EF400*		TF480L	A/D	TF480L	FX480	A/D	FX480	NF480	NF480	T480	T480	T400*
		00	06	EF500	EF500			TF500L	A/D	TF500L	FX500	A/D	FX500	NF500	NF500	T500	T500	
MONTERO CLASSIC		02		EF550	EF500	EX351		TF550L	A/D	TF500L	FX550	A/D	FX500	NF550	NF500	T550	T500	
OUTLANDER		03	06	EF550	EF450	EX306		TF550L	A/D	TF450L	FX550	A/D	FX450	NF550	NF450	T550	T450	
		06	12	HF600	HF530	EX306		TF600L	A/D	TF530L	FX600	A/D	FX530	NF600	NF530	T600	T530	
		13		HF650	HF450	EX306		TF650L	A/D	TF450L	FX650	A/D	FX450	NF650	NF450	T650	T450	
OUTLANDER Van		06	12	HF600	HF530			TF600L	A/D	TF500L	FX600	A/D	FX500	NF600	NF500	T600	T530	
		13		HF650	HF450			TF650L	A/D	TF450L	FX650	A/D	FX450	NF650	NF450	T650	T450	
PAJERO		83	91	EF400	EF400	EF380*		TF400L	A/D	TF400L	FX400	A/D	FX400	NF400	NF400	T400	T400	T380*
		90	99	EF480	EF480	EF400*		TF480L	A/D	TF480L	FX480	A/D	FX480	NF480	NF480	T480	T480	T400*
		00	06	EF500	EF500			TF500L	A/D	TF500L	FX500	A/D	FX500	NF500	NF500	T500	T500	
		07		EF550	EF500	EX351		TF550L	A/D	TF500L	FX550	A/D	FX500	NF550	NF500	T550	T500	
PAJERO CLASSIC		02	05	EF500	EF500	EF400		TF500L	A/D	TF500L	FX500	A/D	FX500	NF500	NF500	T500	T500	T400
		06		EF550	EF500	EX351		TF550L	A/D	TF500L	FX550	A/D	FX500	NF550	NF500	T550	T500	
PAJERO IV Van		06		EF500	EF500			TF500L	A/D	TF500L	FX500	A/D	FX500	NF500	NF500	T500	T500	
PAJERO PININ		99	07	EF450	EF480	EF400		TF450L	A/D	TF480L	FX450	A/D	FX480	NF450	NF480	T450	T480	T400
PAJERO SPORT		97		EF500	EF500	EF430		TF500L	A/D	TF500L	FX500	A/D	FX500	NF500	NF500	T500	T500	T430
PAJERO SPORT VAN		99	08	EF500	EF500			TF500L	A/D	TF500L	FX500	A/D	FX500	NF500	NF500	T500	T500	
PAJERO TR4		07		EF450	EF480	EF400		TF450L	A/D	TF480L	FX450	A/D	FX480	NF450	NF480	T450	T480	T400
SANTAMO		99	04	EF550	EF450	EF400		TF550L	A/D	TF450L	FX550	A/D	FX450	NF550	NF450	T550	T450	T400
SAPPORO		78	90	EF450*	EF450*											T450*	T450*	
SHOGUN		83	91	EF400	EF400	EF380*		TF400L	A/D	TF400L	FX400	A/D	FX400	NF400	NF400	T400	T400	T380*

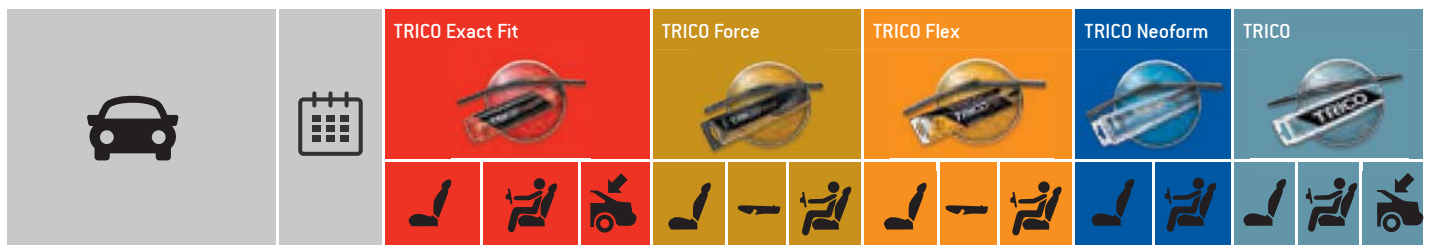













...MITSUBISHI

...SHOGUN	90	99	EF480	EF480	EF400*	TF480L	A/D	TF480L	FX480	A/D	FX480	NF480	NF480	T480	T480	T400*	
	00	06	EF500	EF500		TF500L	A/D	TF500L	FX500	A/D	FX500	NF500	NF500	T500	T500		
		07	EF550	EF500	EX351	TF550L	A/D	TF500L	FX550	A/D	FX500	NF550	NF500	T550	T500		
SHOGUN CLASSIC		02	EF550	EF500	EX351	TF550L	A/D	TF500L	FX550	A/D	FX500	NF550	NF500	T550	T500		
SHOGUN PININ		99	07	EF450	EF480	EF400	TF450L	A/D	TF480L	FX450	A/D	FX480	NF450	NF480	T450	T480	T400
SIGMA 		90	96	EF500	EF480		TF500L	A/D	TF480L	FX500	A/D	FX480	NF500	NF480	T500	T480	
		92	96	EF500	EF480	EF400	TF500L	A/D	TF480L	FX500	A/D	FX480	NF500	NF480	T500	T480	T400
SPACE GEAR		95	00	EF651	EF651	EF430										T430	
SPACE RUNNER		91	99	EF550	EF450	EF400	TF550L	A/D	TF450L	FX550	A/D	FX450	NF550	NF450	T550	T450	T400
		99	02	EF651	EF400	EF380									T400	T380	
SPACE STAR		98	04	EF530	EF450	EF330	TF530L	A/D	TF450L	FX530	A/D	FX450	NF530	NF450	T530	T450	T330
			12	EF550	EF530	EX305	TF550L	A/D	TF530L	FX550	A/D	FX530	NF550	NF530	T550	T530	
SPACE WAGON		91	98	EF550	EF450	EF400	TF550L	A/D	TF450L	FX550	A/D	FX450	NF550	NF450	T550	T450	T400
SPACE		98	04	EF651	EF400	EF380									T400	T380	
STARION		82	90	EF450*	EF450*	EF430*									T450*	T450*	T430*
TREDIA		82	87	EF450*	EF450*	EF380*									T450*	T450*	T380*



MORRIS

ITAL 		80	84	EF400	EF400		TF400L	A/D	TF400L	FX400	A/D	FX400	NF400	NF400	T400	T400	
		80	84	EF400	EF400		TF400L	A/D	TF400L	FX400	A/D	FX400	NF400	NF400	T400	T400	
MARINA 		71	80	EF400	EF400		TF400L	A/D	TF400L	FX400	A/D	FX400	NF400	NF400	T400	T400	
		71	80	EF400	EF400		TF400L	A/D	TF400L	FX400	A/D	FX400	NF400	NF400	T400	T400	
		71	75	EF400	EF400		TF400L	A/D	TF400L	FX400	A/D	FX400	NF400	NF400	T400	T400	
MARINA Van		75	80	EF400	EF400		TF400L	A/D	TF400L	FX400	A/D	FX400	NF400	NF400	T400	T400	
MINOR 		55	71	EF280	EF280										T280	T280	
		55	71	EF280	EF280										T280	T280	
		62	69	EF280	EF280										T280	T280	
MINOR Van		62	71	EF280	EF280										T280	T280	
OXFORD		59	70	EF350	EF350		TF350L	A/D	TF350L	FX350	A/D	FX350	NF350	NF350	T350	T350	

MOSKVICH

403		62		EF330	EF330										T330	T330	
407		58		EF330	EF330										T330	T330	
412		71		EF330	EF330										T330	T330	
423		59		EF330	EF330										T330	T330	
427		75		EF330	EF330										T330	T330	
2140		78	83	EF330	EF330										T330	T330	
21412		89		EF330	EF330										T330	T330	
ASLK 		76		EF330	EF330										T330	T330	
ASLK 		76		EF330	EF330										T330	T330	

NISSAN

100 NX		90	94	EF500	EF480		TF500L	A/D	TF480L	FX500	A/D	FX480	NF500	NF480	T500	T480	
180 SX		88	94	EF500	EF500		TF500L	A/D	TF500L	FX500	A/D	FX500	NF500	NF500	T500	T500	
200 SX		88	99	EF500	EF500		TF500L	A/D	TF500L	FX500	A/D	FX500	NF500	NF500	T500	T500	
240 SX		88	01	EF500	EF500		TF500L	A/D	TF500L	FX500	A/D	FX500	NF500	NF500	T500	T500	
300 ZX 		89	97	EF530	EF530		TF530L	A/D	TF530L	FX530	A/D	FX530	NF530	NF530	T530	T530	
300 ZX 		84	90	EF480	EF480		TF480L	A/D	TF480L	FX480	A/D	FX480	NF480	NF480	T480	T480	
350 Z 		03	09	EF500	EF450		TF500L	A/D	TF450L	FX500	A/D	FX450	NF500	NF450	T500	T450	



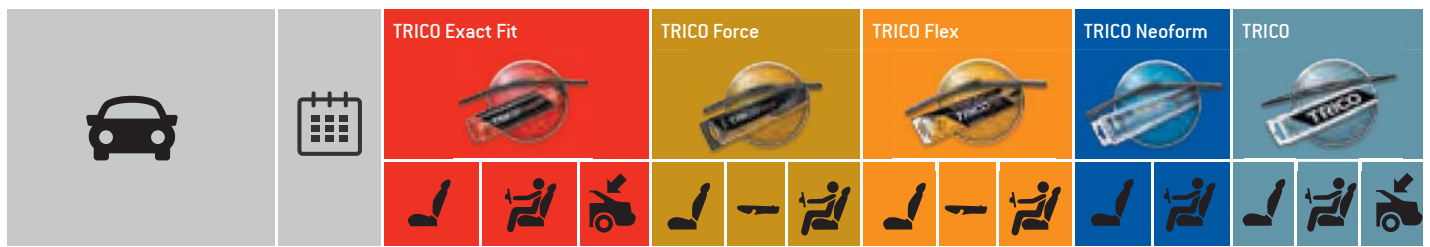



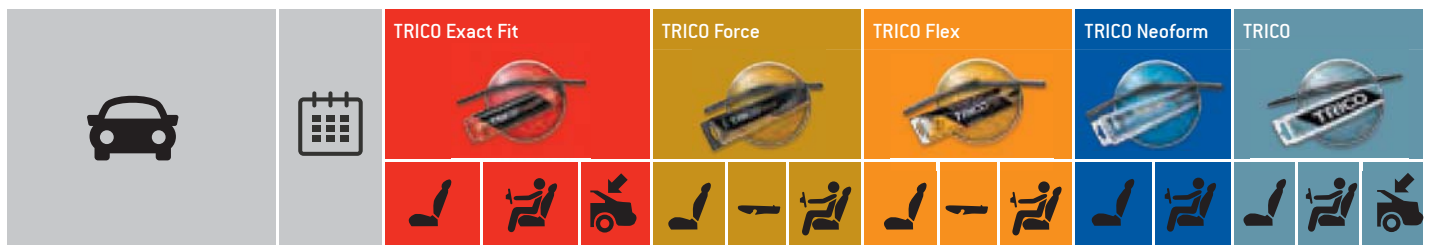

...NISSAN

Model	Icon	Year 1	Year 2	TRICO Exact Fit	TRICO Force	TRICO Flex	TRICO Neoform	TRICO
...350 Z		05	09	EF500 EF450	TF500L A/D	TF450L FX500	A/D FX450 NF500 NF450	T500 T450
370 Z		09		HF600 HF480	TF600L A/D	TF480L FX600	A/D FX480 NF600 NF480	
		10		HF600 HF480	TF600L A/D	TF480L FX600	A/D FX480 NF600 NF480	
ALMERA		95	00	EF530 EF480	TF530L A/D	TF480L FX530	A/D FX480 NF530 NF480	T530 T480
		00	06	EF550 EF430	TF550L A/D	TF430L FX550	A/D FX430 NF550 NF430	T550 T430
		95	00	EF530 EF480 EF350	TF530L A/D	TF480L FX530	A/D FX480 NF530 NF480	T530 T480 T350
		00	06	EF550 EF430 EX353	TF550L A/D	TF430L FX550	A/D FX430 NF550 NF430	T550 T430
ALMERA TINO		00	06	EF650 EF450 EF500	TF650L A/D	TF450L FX650	A/D FX450 NF650 NF450	T650 T450 T500
ALTIMA		93	01	EF530 EF500	TF530L A/D	TF500L FX530	A/D FX500 NF530 NF500	T530 T500
		01	06	EF650 EF430	TF650L A/D	TF430L FX650	A/D FX430 NF650 NF430	T650 T430
		06		EF650 EF430	TF650L A/D	TF430L FX650	A/D FX430 NF650 NF430	T650 T430
BLUEBIRD		72	79	EF400* EF400* EF330				T400* T400* T330
		83	97	EF480 EF480	TF480L A/D	TF480L FX480	A/D FX480 NF480 NF480	T480 T480
		85	92	EF480 EF480 EF500	TF480L A/D	TF480L FX480	A/D FX480 NF480 NF480	T480 T480 T500
		80	90	EF480 EF480 EF380	TF480L A/D	TF480L FX480	A/D FX480 NF480 NF480	T480 T480 T380
		80	84	EF450 EF450	TF450L A/D	TF450L FX450	A/D FX450 NF450 NF450	T450 T450
CABSTAR		82	92	EF500 EF500	TF500L A/D	TF500L FX500	A/D FX500 NF500 NF500	T500 T500
CHERRY		70	78	EF380 EF380	TF350L A/D	TF350L FX350	A/D FX350 NF350 NF350	T380 T380
		78	82	EF430 EF430 EF430	TF430L A/D	TF430L FX430	A/D FX430 NF430 NF430	T430 T430 T430
		82	86	EF450 EF450 EF450	TF450L A/D	TF450L FX450	A/D FX450 NF450 NF450	T450 T450 T450
		78	83	EF430 EF430 EF430	TF430L A/D	TF430L FX430	A/D FX430 NF430 NF430	T430 T430 T430
		78	82	EF430 EF430	TF430L A/D	TF430L FX430	A/D FX430 NF430 NF430	T430 T430
CUBE		10		EF500 EF500	TF500L A/D	TF500L FX500	A/D FX500 NF500 NF500	T500 T500
DATSUN 100 A		74	80	EF350 EF350	TF350L A/D	TF350L FX350	A/D FX350 NF350 NF350	T350 T350
		75	80	EF350 EF350	TF350L A/D	TF350L FX350	A/D FX350 NF350 NF350	T350 T350
DATSUN 240		78	81	EF400 EF400	TF400L A/D	TF400L FX400	A/D FX400 NF400 NF400	T400 T400
FAIRLADY Z		84	89	EF500 EF450	TF500L A/D	TF450L FX500	A/D FX450 NF500 NF450	T500 T450
INTERSTAR		02	09	EF603 EF603				
JUKE		10		EF580 EF350 EX300	TF550L A/D	TF350L FX550	A/D FX350 NF550 NF350	T580 T350
		10		EF580 EF350 EX281	TF550L A/D	TF350L FX550	A/D FX350 NF550 NF350	T580 T350
KUBISTAR	MPV	03		EF500 EF500 EX404	TF500L A/D	TF500L FX500	A/D FX500 NF500 NF500	T500 T500
KUBISTAR Van		03		EF500 EF500	TF500L A/D	TF500L FX500	A/D FX500 NF500 NF500	T500 T500
LAUREL		77	85	EF430* EF430*				T430* T430*
		84	89	EF480 EF480	TF480L A/D	TF480L FX480	A/D FX480 NF480 NF480	T480 T480
LEAF		10		HF650 HF400 EX252	TF650L A/D	TF400L FX650	A/D FX400 NF650 NF400	
MAXIMA		88	94	EF530 EF500	TF530L A/D	TF500L FX530	A/D FX500 NF530 NF500	T530 T500
		97		EF650 EF430	TF650L A/D	TF430L FX650	A/D FX430 NF650 NF430	T650 T430
MAXIMA QX		94	00	EF550 EF530	TF550L A/D	TF530L FX550	A/D FX530 NF550 NF530	T550 T530
		99	03	EF650 EF430	TF650L A/D	TF430L FX650	A/D FX430 NF650 NF430	T650 T430
MICRA		82	92	EF450 EF450 EF450	TF450L A/D	TF450L FX450	A/D FX450 NF450 NF450	T450 T450 T450
		92	99	EF500 EF450 EF450	TF500L A/D	TF450L FX500	A/D FX450 NF500 NF450	T500 T450 T450
		00	03	EF500 EF450 EX404	TF500L A/D	TF450L FX500	A/D FX450 NF500 NF450	T500 T450
		03	05	EF530 EF450 EX300	TF530L A/D	TF450L FX530	A/D FX450 NF530 NF450	T530 T450
		05	10	EF530 EF450 EX404	TF530L A/D	TF450L FX530	A/D FX450 NF530 NF450	T530 T450
		10		EF530 EF350 EX306	TF530L A/D	TF350L FX530	A/D FX350 NF530 NF350	T530 T350
		05		EF530 EF450	TF530L A/D	TF450L FX530	A/D FX450 NF530 NF450	T530 T450





...NISSAN

MURANO		03	08	HF650	HF450	EX351	TF600L	A/D	TF480L	FX600	A/D	FX480	NF650	NF450			
		08		HF650	HF400	EX306	TF650L	A/D	TF400L	FX650	A/D	FX400	NF650	NF400			
NAVARA		92	97	EF480	EF480		TF480L	A/D	TF480L	FX480	A/D	FX480	NF480	NF480	T480	T480	
		04	14	EF600	EF480		TF600L	A/D	TF480L	FX600	A/D	FX480	NF600	NF480	T600	T480	
		14		HF600	HF480		TF600L	A/D	TF480L	FX600	A/D	FX480	NF600	NF480	T600	T480	
NOTE		06	13	EF600	EF350	EX306	TF600L	A/D	TF350L	FX600	A/D	FX350	NF600	NF350	T600	T350	
		13		HF650		EX306	TF650L	A/D		FX650	A/D		NF650		T650	T280	
NP300		08		HF600	HF480		TF600L	A/D	TF480L	FX600	A/D	FX480	NF600	NF480			
NV200		10		EF550	EF400		TF550L	A/D	TF400L	FX550	A/D	FX400	NF550	NF400	T550	T400	
NV200 EVALIA		10		EF550	EF400		TF550L	A/D	TF400L	FX550	A/D	FX400	NF550	NF400	T550	T400	
NV400		11		EF650	EF650		TF650L	A/D	TF650L	FX650	A/D	FX650	NF650	NF650	T650	T650	
PATHFINDER		86	95	EF480	EF480	EF280									T480	T480	T280
		97	04	EF550	EF530		TF550L	A/D	TF530L	FX550	A/D	FX530	NF550	NF530	T550	T530	
		05		EF600	EF480	EX306	TF600L	A/D	TF480L	FX600	A/D	FX480	NF600	NF480	T600	T480	
PATROL		79	98	EF400	EF400	EF280	TF400L	A/D	TF400L	FX400	A/D	FX400	NF400	NF400	T400	T400	T280
		88	98	EF480	EF480	EF280	TF480L	A/D	TF480L	FX480	A/D	FX480	NF480	NF480	T480	T480	T280
		10		HF480	HF500	EF350	TF480L	A/D	TF500L	FX480	A/D	FX500	NF480	NF500			T350
PATROL GR		97		EF480	EF480	EF280	TF480L	A/D	TF480L	FX480	A/D	FX480	NF480	NF480	T480	T480	T280
PICK UP		80	86	EF400	EF400		TF400L	A/D	TF400L	FX400	A/D	FX400	NF400	NF400	T400	T400	
		85	98	EF480	EF480		TF480L	A/D	TF480L	FX480	A/D	FX480	NF480	NF480	T480	T480	
		97		EF450	EF450		TF450L	A/D	TF450L	FX450	A/D	FX450	NF450	NF450	T450	T450	
PIXO		09		EF530	EF350		TF530L	A/D	TF350L	FX530	A/D	FX350	NF530	NF350	T530	T350	
PRAIRIE		83	88	EF450	EF450	EF400	TF450L	A/D	TF450L	FX450	A/D	FX450	NF450	NF450	T450	T450	T400
PRAIRIE PRO		88	94	EF480	EF480	EF400	TF480L	A/D	TF480L	FX480	A/D	FX480	NF480	NF480	T480	T480	T400
PRIMASTAR		01		EF600	EF530	EX404	TF600L	A/D	TF530L	FX600	A/D	FX530	NF600	NF530	T600	T530	
PRIMERA 		90	01	EF530	EF480		TF530L	A/D	TF480L	FX530	A/D	FX480	NF530	NF480	T530	T480	
		02	08	EF650	EF480		TF650L	A/D	TF480L	FX650	A/D	FX480	NF650	NF480	T650	T480	
		90	02	EF530	EF480	EF530	TF530L	A/D	TF480L	FX530	A/D	FX480	NF530	NF480	T530	T480	T530
		02	08	EF650	EF480	EX500	TF650L	A/D	TF480L	FX650	A/D	FX480	NF650	NF480	T650	T480	
		90	01	EF530	EF480	EF380	TF530L	A/D	TF480L	FX530	A/D	FX480	NF530	NF480	T530	T480	T380
		02	08	EF650	EF480	EX404	TF650L	A/D	TF480L	FX650	A/D	FX480	NF650	NF480	T650	T480	
PULSAR		14		EFB6518L	EFB3518L	EX300	TF650L	BC	TF350L	FX650	BC	FX350	NF659	NF359			
QASHQAI / +2	MPV	07	13	EFB6017L	EFB4017L	EX308	TF600L	BC	TF400L	FX600	BC	FX400	NF607	NF407			
	SUV	07	13	EFB6017L	EFB4017L	EX308	TF600L	BC	TF400L	FX600	BC	FX400	NF607	NF407			
		14		HF650	HF430	EX300	TF650L	A/D	TF430L	FX650	A/D	FX430	NF650	NF430			
QUEST		92	98	EF550	EF550		TF550L	A/D	TF550L	FX550	A/D	FX550	NF550	NF550	T550	T550	
		03		EF700	EF450		TF700L	A/D	TF450L	FX700	A/D	FX450	NF700	NF450	T700	T450	
SENTRA		98		EF550	EF400		TF550L	A/D	TF400L	FX550	A/D	FX400	NF550	NF400	T550	T400	
SERENA		92	01	EF600	EF600	EF400	TF600L	A/D	TF600L	FX600	A/D	FX600	NF600	NF600	T600	T600	T400
		00	05	EF600	EF600		TF600L	A/D	TF600L	FX600	A/D	FX600	NF600	NF600	T600	T600	
SILVIA		79	83	EF450*	EF450*										T450*	T450*	
		84	88	EF480	EF480		TF480L	A/D	TF480L	FX480	A/D	FX480	NF480	NF480	T480	T480	
STANZA 		81	89	EF450	EF450		TF450L	A/D	TF450L	FX450	A/D	FX450	NF450	NF450	T450	T450	
		81	85	EF450	EF450	EF450	TF450L	A/D	TF450L	FX450	A/D	FX450	NF450	NF450	T450	T450	T450
SUNNY 		70	82	EF380	EF380		TF350L	A/D	TF350L	FX350	A/D	FX350	NF350	NF350	T380	T380	
		82	91	EF450	EF450										T450	T450	



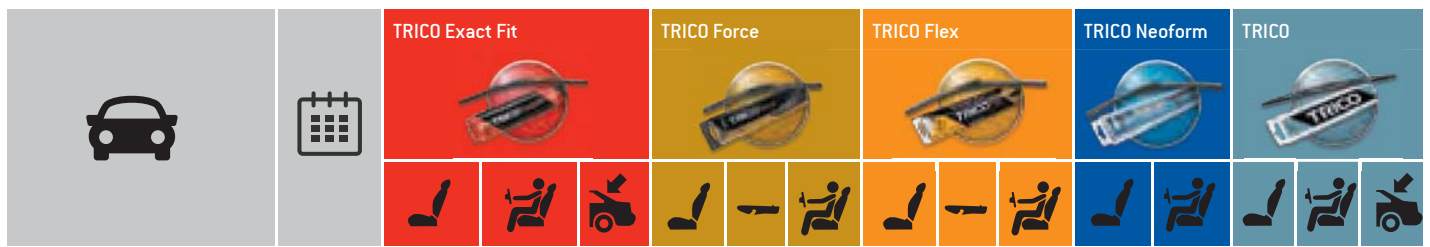

...NISSAN

...SUNNY		90	03	EF530	EF450											T530	T450	
		86	91	EF450	EF450	EF450										T450	T450	T450
		90	03	EF530	EF450	EF500	TF530L	A/D	TF450L	FX530	A/D	FX450	NF530	NF450		T530	T450	T500
		79	82	EF400	EF400	EF350										T400	T400	T350
		82	91	EF450	EF450	EF400										T450	T450	T400
		90	00	EF530	EF450	EF350										T530	T450	T350
		82	90	EF450	EF450											T450	T450	
		86	91	EF450	EF450	EF450										T450	T450	T450
		95	03	EF530	EF450		TF530L	A/D	TF450L	FX530	A/D	FX450	NF530	NF450		T530	T450	
SUNNY Van		90	00	EF530	EF450											T530	T450	
TERRANO		86	91	EF480	EF480	EF280	TF480L	A/D	TF480L	FX480	A/D	FX480	NF480	NF480		T480	T480	T280
		92	06	EF530	EF500	EF280	TF530L	A/D	TF500L	FX530	A/D	FX500	NF530	NF500		T530	T500	T280
TERRANO Van		98	06	EF530	EF480		TF530L	A/D	TF480L	FX530	A/D	FX480	NF530	NF480		T530	T480	
TIIDA		06		EF600	EF350		TF600L	A/D	TF350L	FX600	A/D	FX350	NF600	NF350		T600	T350	
		07		EF600	EF350	EX350	TF600L	A/D	TF350L	FX600	A/D	FX350	NF600	NF350		T600	T350	
TITAN		03		EF600	EF550		TF600L	A/D	TF350L	FX600	A/D	FX350	NF600	NF350		T600	T550	
URVAN		80		EF450	EF450	EF380	TF450L	A/D	TF450L	FX450	A/D	FX450	NF450	NF450		T450	T450	T380
VANETTE		86	95	EF450	EF450	EF380	TF450L	A/D	TF450L	FX450	A/D	FX450	NF450	NF450		T450	T450	T380
VANETTE CARGO		94	05	EF600	EF600	EF400	TF600L	A/D	TF600L	FX600	A/D	FX600	NF600	NF600		T600	T600	T400
VANETTE Van		81	87	EF400	EF400		TF400L	A/D	TF400L	FX400	A/D	FX400	NF400	NF400		T400	T400	
X-TRAIL		01	03	EF600	EF380	EF430	TF600L	A/D	TF350L	FX600	A/D	FX350	NF600	NF350		T600	T380	T430
		04	13	EF600	EF380	EX351	TF600L	A/D	TF350L	FX600	A/D	FX350	NF600	NF350		T600	T380	
		14		HF650	HF430	EX300	TF650L	A/D	TF430L	FX650	A/D	FX430	NF650	NF430				
ZXT		78	84	EF450*	EF450*	EF380										T450*	T450*	T380

NSU

RO 80		67	77	EF400	EF400		TF400L	A/D	TF400L	FX400	A/D	FX400	NF400	NF400		T400	T400	
-------	--	----	----	-------	-------	--	--------	-----	--------	-------	-----	-------	-------	-------	--	------	------	--

OLDSMOBILE

CUTLASS CIERA		89	06	EF450	EF450		TF450L	A/D	TF450L	FX450	A/D	FX450	NF450	NF450		T450	T450	
CUTLASS SUPREME		88		EF500	EF500		TF500L	A/D	TF500L	FX500	A/D	FX500	NF500	NF500		T500	T500	

OPEL

ADAM		12		EFB6518L	EFB4018L	EX357	TF650L	BC	TF400L	FX650	BC	FX400	NF659	NF409				
AGILA		00	07	EF500	EF450	EF330	TF500L	A/D	TF450L	FX500	A/D	FX450	NF500	NF450		T500	T450	T330
		08		EF550	EF450	EX252	TF550L	A/D	TF450L	FX550	A/D	FX450	NF550	NF450		T550	T450	
AMPERA		11		EFB6518L	EFB6518R		TF650L	BC	TF650R	FX650	BC	FX650	NF659	NF659				
ANTARA		06		EF600	EF400		TF600L	A/D	TF400L	FX600	A/D	FX400	NF600	NF400		T600	T400	
ARENA		97	01	EF500	EF500		TF500L	A/D	TF500L	FX500	A/D	FX500	NF500	NF500		T500	T500	
ASCONA		70	75	EF400	EF400		TF400L	A/D	TF400L	FX400	A/D	FX400	NF400	NF400		T400	T400	
		75	88	EF450	EF450		TF450L	A/D	TF450L	FX450	A/D	FX450	NF450	NF450		T450	T450	
		81	88	EF450	EF450	EF500	TF450L	A/D	TF450L	FX450	A/D	FX450	NF450	NF450		T450	T450	T500
		70	75	EF400	EF400		TF400L	A/D	TF400L	FX400	A/D	FX400	NF400	NF400		T400	T400	
ASTRA		91	98	EF450	EF450		TF450L	A/D	TF450L	FX450	A/D	FX450	NF450	NF450		T450	T450	
		98	04	EF500	EF480		TF500L	A/D	TF480L	FX500	A/D	FX480	NF500	NF480		T500	T480	
		04	10	EFB556	EFB456		TF550L	BC	TF450L	FX550	BC+E	FX450	NF556	NF456				
		12		EFB6518L	EFB6518R		TF650L	BC	TF650R	FX650	BC	FX650	NF659	NF659				
		91	98	EF450	EF450	EF450	TF450L	A/D	TF450L	FX450	A/D	FX450	NF450	NF450		T450	T450	T450
		98	04	EF500	EF480	EX404	TF500L	A/D	TF480L	FX500	A/D	FX480	NF500	NF480		T500	T480	

TRICO Exact Fit TRICO Force TRICO Flex TRICO Neoform TRICO

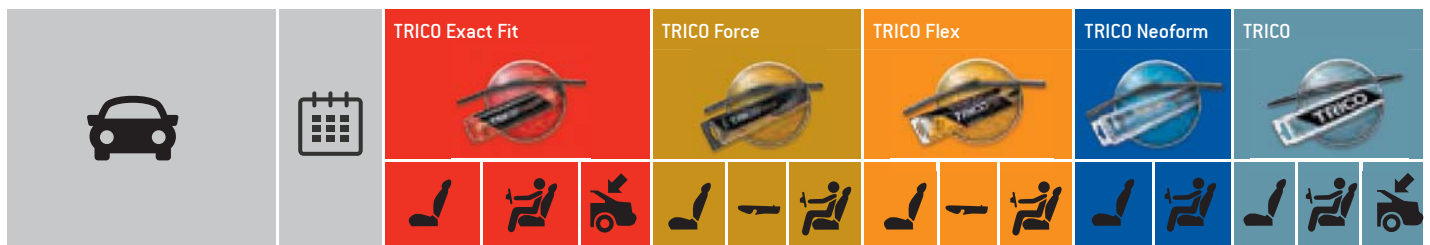

...OPEL

...ASTRA		04	09	EFB556	EFB456	EX308	TF550L	BC	TF450L	FX550	BC+E	FX450	NF556	NF456			
		10		EFB6518L	EFB6518R	EX310	TF650L	BC	TF650R	FX650	BC	FX650	NF659	NF659			
		91	98	EF450	EF450	EF400	TF450L	A/D	TF450L	FX450	A/D	FX450	NF450	NF450	T450	T450	T400
		98	04	EF500	EF480	EX282	TF500L	A/D	TF480L	FX500	A/D	FX480	NF500	NF480	T500	T480	
		04	10	EFB556	EFB456	EX308	TF550L	BC	TF450L	FX550	BC+E	FX450	NF556	NF456			
		10		EFB6518L	EFB6518R	EX310	TF650L	BC	TF650R	FX650	BC	FX650	NF659	NF659			
		00	05	EF500	EF480		TF500L	A/D	TF480L	FX500	A/D	FX480	NF500	NF480	T500	T480	
		05	09	EFB556	EFB456	EX230	TF550L	BC	TF450L	FX550	BC+E	FX450	NF556	NF456			
		12		EFB7318L	EFB6018R	EX310	TF730L	BC	TF600R	FX730	BC	FX600	NF739	NF609			
		93	01	EF450	EF450		TF450L	A/D	TF450L	FX450	A/D	FX450	NF450	NF450	T450	T450	
		01	05	EF500	EF480		TF500L	A/D	TF480L	FX500	A/D	FX480	NF500	NF480	T500	T480	
		05	10	EFB556	EFB456		TF550L	BC	TF450L	FX550	BC+E	FX450	NF556	NF456			
ASTRA CLASSIC		98	02	EF450	EF450		TF450L	A/D	TF450L	FX450	A/D	FX450	NF450	NF450	T450	T450	
		98	02	EF450	EF450	EF450	TF450L	A/D	TF450L	FX450	A/D	FX450	NF450	NF450	T450	T450	T450
		98	05	EF450	EF450	EF330	TF450L	A/D	TF450L	FX450	A/D	FX450	NF450	NF450	T450	T450	T330
ASTRA Van		91	99	EF450	EF450		TF450L	A/D	TF450L	FX450	A/D	FX450	NF450	NF450	T450	T450	
		99	05	EF500	EF480		TF500L	A/D	TF480L	FX500	A/D	FX480	NF500	NF480	T500	T480	
		04	10	EFB556	EFB456	EX308	TF550L	BC	TF450L	FX550	BC+E	FX450	NF556	NF456			
CALIBRA		90	97	EF480	EF480		TF480L	A/D	TF480L	FX480	A/D	FX480	NF480	NF480	T480	T480	
CAMPO		87		EF450	EF450		TF450L	A/D	TF450L	FX450	A/D	FX450	NF450	NF450	T450	T450	
CASCADA		13		EFB6518L	EFB6518L		TF650L	BC	TF650L	FX650	BC	FX650	NF659	NF659			
COMBO	MPV	01	12	EF500	EF430		TF500L	A/D	TF430L	FX500	A/D	FX430	NF500	NF430	T500	T430	
		12		EFB6018L	EFB4018L		TF600L	BC	TF400L	FX600	BC	FX400	NF609	NF409			
COMBO Van		94	01	EF450	EF450		TF450L	A/D	TF450L	FX450	A/D	FX450	NF450	NF450	T450	T450	
		01	12	EF500	EF430		TF500L	A/D	TF430L	FX500	A/D	FX430	NF500	NF430	T500	T430	
		12		EFB6018L	EFB4018L	EX358	TF600L	BC	TF400L	FX600	BC	FX400	NF609	NF409			
COMMODORE		67	72	EF400	EF400		TF400L	A/D	TF400L	FX400	A/D	FX400	NF400	NF400	T400	T400	
		72	78	EF450	EF450		TF450L	A/D	TF450L	FX450	A/D	FX450	NF450	NF450	T450	T450	
		78	82	EF450	EF450		TF450L	A/D	TF450L	FX450	A/D	FX450	NF450	NF450	T450	T450	
		80	82	EF450	EF450	EF400	TF450L	A/D	TF450L	FX450	A/D	FX450	NF450	NF450	T450	T450	T400
		67	72	EF400	EF400		TF400L	A/D	TF400L	FX400	A/D	FX400	NF400	NF400	T400	T400	
		72	78	EF450	EF450	EF400	TF450L	A/D	TF450L	FX450	A/D	FX450	NF450	NF450	T450	T450	T400
CORSA		82	93	EF400	EF400		TF400L	A/D	TF400L	FX400	A/D	FX400	NF400	NF400	T400	T400	
		82	93	EF400	EF400	EF400	TF400L	A/D	TF400L	FX400	A/D	FX400	NF400	NF400	T400	T400	T400
		93	02	EF450	EF450	EF350	TF450L	A/D	TF450L	FX450	A/D	FX450	NF450	NF450	T450	T450	T350
		00	05	EF500	EF450	EX404	TF500L	A/D	TF450L	FX500	A/D	FX450	NF500	NF450	T500	T450	
		06	14	EFB6517L	EFB4017L	EX300	TF650L	BC	TF400L	FX650	BC	FX400	NF657	NF407			
		15		EFB6517L	EFB4017L	EX308	TF650L	BC	TF400L	FX650	BC	FX400	NF657	NF407			
CORSA Van		86	90	EF400	EF400		TF400L	A/D	TF400L	FX400	A/D	FX400	NF400	NF400	T400	T400	
		93	00	EF450	EF450	EF350	TF450L	A/D	TF450L	FX450	A/D	FX450	NF450	NF450	T450	T450	T350
		00	05	EF500	EF450	EX404	TF500L	A/D	TF450L	FX500	A/D	FX450	NF500	NF450	T500	T450	
		06		EFB6517L	EFB4017L	EX300	TF650L	BC	TF400L	FX650	BC	FX400	NF657	NF407			
FRONTERA		92	04	EF480	EF480	EF280	TF480L	A/D	TF480L	FX480	A/D	FX480	NF480	NF480	T480	T480	T280
GT		68	73	EF450	EF450		TF450L	A/D	TF450L	FX450	A/D	FX450	NF450	NF450	T450	T450	
INSIGNIA		08		HF600	HF450		TF600L	A/D	TF450L	FX600	A/D	FX450	NF600	NF450			



...OPEL

...INSIGNIA		08		HF600	HF450	EFB5017L	TF600L	A/D	TF450L	FX600	A/D	FX450	NF600	NF450			
		08		HF600	HF450	EX300	TF600L	A/D	TF450L	FX600	A/D	FX450	NF600	NF450			
KADETT		65	84	EF400	EF400		TF400L	A/D	TF400L	FX400	A/D	FX400	NF400	NF400	T400	T400	
		84	91	EF450	EF450		TF450L	A/D	TF450L	FX450	A/D	FX450	NF450	NF450	T450	T450	
		73	79	EF400	EF400		TF400L	A/D	TF400L	FX400	A/D	FX400	NF400	NF400	T400	T400	
		79	84	EF400	EF400	EF400	TF400L	A/D	TF400L	FX400	A/D	FX400	NF400	NF400	T400	T400	T400
		84	91	EF450	EF450	EF400	TF450L	A/D	TF450L	FX450	A/D	FX450	NF450	NF450	T450	T450	T400
		63	79	EF400	EF400		TF400L	A/D	TF400L	FX400	A/D	FX400	NF400	NF400	T400	T400	
		79	84	EF400	EF400	EF330	TF400L	A/D	TF400L	FX400	A/D	FX400	NF400	NF400	T400	T400	T330
		84	91	EF450	EF450	EF330	TF450L	A/D	TF450L	FX450	A/D	FX450	NF450	NF450	T450	T450	T330
		65	79	EF400	EF400		TF400L	A/D	TF400L	FX400	A/D	FX400	NF400	NF400	T400	T400	
		86	93	EF450	EF450		TF450L	A/D	TF450L	FX450	A/D	FX450	NF450	NF450	T450	T450	
KADETT Van		84	94	EF450	EF450		TF450L	A/D	TF450L	FX450	A/D	FX450	NF450	NF450	T450	T450	
KARL		15		EF600	EF350		TF600L	A/D	TF350L	FX600	A/D	FX350	NF600	NF350	T600	T350	
MANTA		75	88	EF450	EF450		TF450L	A/D	TF450L	FX450	A/D	FX450	NF450	NF450	T450	T450	
MERIVA		03	10	EF600	EF600	EX404	TF600L	A/D	TF600R	FX600	A/D	FX600	NF600	NF600	T600	T600	
		10		EFB7018L	EFB5318R	EX404	TF700L	BC	TF550R	FX700	BC	FX550	NF709	NF539			
MOKKA		12		EFB6518L	EFB3518L		TF650L	BC	TF350L	FX650	BC	FX350	NF659	NF359			
MONTEREY		91	99	EF500	EF500	EF380	TF500L	A/D	TF500L	FX500	A/D	FX500	NF500	NF500	T500	T500	T380
MONZA		78	86	EF450	EF450	EF500	TF450L	A/D	TF450L	FX450	A/D	FX450	NF450	NF450	T450	T450	T500
MOVANO		98	09	EF603	EF603												
		10		EF650	EF650		TF650L	A/D	TF650L	FX650	A/D	FX650	NF650	NF650	T650	T650	
OMEGA		86	94	EF480	EF480		TF480L	A/D	TF480L	FX480	A/D	FX480	NF480	NF480	T480	T480	
		94	03	EF600	EF480		TF600L	A/D	TF480L	FX600	A/D	FX480	NF600	NF480	T600	T480	
		86	94	EF480	EF480	EF330	TF480L	A/D	TF480L	FX480	A/D	FX480	NF480	NF480	T480	T480	T330
		94	03	EF600	EF480	EF350	TF600L	A/D	TF480L	FX600	A/D	FX480	NF600	NF480	T600	T480	T350
REKORD		72	86	EF450	EF450		TF450L	A/D	TF450L	FX450	A/D	FX450	NF450	NF450	T450	T450	
		72	86	EF450	EF450	EF400	TF450L	A/D	TF450L	FX450	A/D	FX450	NF450	NF450	T450	T450	T400
		72	77	EF450	EF450		TF450L	A/D	TF450L	FX450	A/D	FX450	NF450	NF450	T450	T450	
SENATOR		78	87	EF450	EF450		TF450L	A/D	TF450L	FX450	A/D	FX450	NF450	NF450	T450	T450	
		87	93	EF480	EF480		TF480L	A/D	TF480L	FX480	A/D	FX480	NF480	NF480	T480	T480	
SIGNUM		03	08	EF600	EF480	EX354	TF600L	A/D	TF480L	FX600	A/D	FX480	NF600	NF480	T600	T480	
SINTRA		96	99	EF600	EF600	EF400	TF600L	A/D	TF600R	FX600	A/D	FX600	NF600	NF600	T600	T600	T400
TIGRA		94	00	EF450	EF450	EF500	TF450L	A/D	TF450L	FX450	A/D	FX450	NF450	NF450	T450	T450	T500
		04		EF500	EF450		TF500L	A/D	TF450L	FX500	A/D	FX450	NF500	NF450	T500	T450	
VECTRA		88	95	EF480	EF480		TF480L	A/D	TF480L	FX480	A/D	FX480	NF480	NF480	T480	T480	
		95	02	EF480	EF480		TF480L	A/D	TF480L	FX480	A/D	FX480	NF480	NF480	T480	T480	
		02	08	EF600	EF480		TF600L	A/D	TF480L	FX600	A/D	FX480	NF600	NF480	T600	T480	
		88	95	EF480	EF480	EF480	TF480L	A/D	TF480L	FX480	A/D	FX480	NF480	NF480	T480	T480	T480
		95	02	EF600	EF480	EF480	TF480L	A/D	TF480L	FX480	A/D	FX480	NF600	NF480	T600	T480	T480
		02	05	EF600	EF480	EX404	TF600L	A/D	TF480L	FX600	A/D	FX480	NF600	NF480	T600	T480	
		05	08	EF600	EF480	EX400	TF600L	A/D	TF480L	FX600	A/D	FX480	NF600	NF480	T600	T480	
		95	02	EF480	EF480	EF330	TF480L	A/D	TF480L	FX480	A/D	FX480	NF480	NF480	T480	T480	T330
		03	08	EF600	EF480		TF600L	A/D	TF480L	FX600	A/D	FX480	NF600	NF480	T600	T480	
VIVARO		01	14	EF600	EF530		TF600L	A/D	TF530L	FX600	A/D	FX530	NF600	NF530	T600	T530	
		14		EFB6518L	EFB4818L	EFB4017L	TF650L	BC	TF480L	FX650	BC	FX480	NF659	NF489			



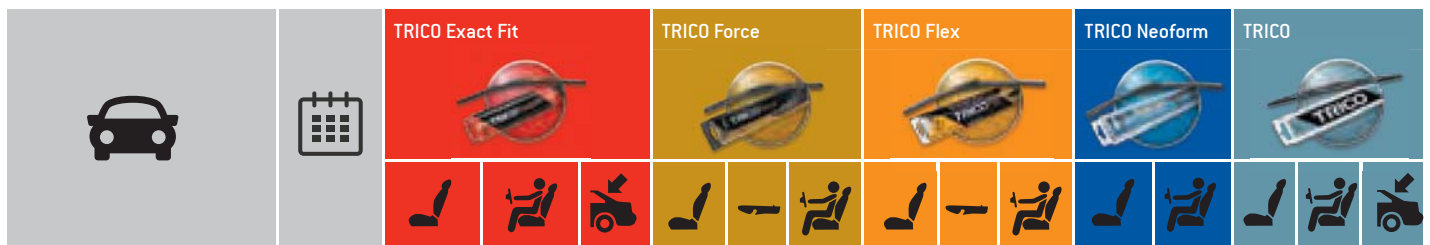

...OPEL

...VIVARO		14		EFB6518L	EFB4818L	EX404x2	TF650L	BC	TF480L	FX650	BC	FX480	NF659	NF489			
ZAFIRA		99	05	EF600	EF600	EX404	TF600L	A/D	TF600R	FX600	A/D	FX600	NF600	NF600	T600	T600	
			05	12	EFB7017L	EFB5517R	EX353	TF700L	BC	TF550R	FX700	BC	FX550	NF707	NF557		
ZAFIRA Tourer		12			EFB8018L	EFB7018R		TF800L	BC		FX800	BC	FX700	NF809	NF709		

PEUGEOT

104		72	88	EF350	EF350	EF350	TF350L	A/D	TF350L	FX350	A/D	FX350	NF350	NF350	T350	T350	T350
		73	88	EF350	EF350		TF350L	A/D	TF350L	FX350	A/D	FX350	NF350	NF350	T350	T350	
106		91	99	EF500	EF450	EF400	TF500L	A/D	TF450L	FX500	A/D	FX450	NF500	NF450	T500	T450	T400
		99	04	EF500	EF450	EX404	TF500L	A/D	TF450L	FX500	A/D	FX450	NF500	NF450	T500	T450	
106 Van		96	04	EF500	EF450		TF500L	A/D	TF450L	FX500	A/D	FX450	NF500	NF450	T500	T450	
107		05		EF650		EX301	TF650L	A/D		FX650	A/D		NF650		T650		
108		14		EFB6517L		EX305	TF650L	BC		FX650	BC		NF657				
204		65	77	EF330	EF330										T330	T330	
		68	77	EF330	EF330										T330	T330	
		69	70	EF330	EF330										T330	T330	
		67	70	EF330	EF330										T330	T330	
205		83	98	EF450	EF450	EF450	TF450L	A/D	TF450L	FX450	A/D	FX450	NF450	NF450	T450	T450	T450
		86	94	EF450	EF450		TF450L	A/D	TF450L	FX450	A/D	FX450	NF450	NF450	T450	T450	
205 Van		83	90	EF450	EF450		TF450L	A/D	TF450L	FX450	A/D	FX450	NF450	NF450	T450	T450	
206		07		EF650	EF400		TF650L	A/D	TF400L	FX650	A/D	FX400	NF650	NF400	T650	T400	
		98	99	EF650	EF480	EX353	TF650L	A/D	TF480L	FX650	A/D	FX480	NF650	NF480	T650	T480	
		00		EF650	EF400	EX353	TF650L	A/D	TF400L	FX650	A/D	FX400	NF650	NF400	T650	T400	
206 CC		00		EF650	EF400		TF650L	A/D	TF400L	FX650	A/D	FX400	NF650	NF400	T650	T400	
206 SW		02		EF650	EF400	EX357	TF650L	A/D	TF400L	FX650	A/D	FX400	NF650	NF400	T650	T400	
206 Van		00	09	EF650	EF400	EX353	TF650L	A/D	TF400L	FX650	A/D	FX400	NF650	NF400	T650	T400	
207		06		EFB656	EFB436		TF650L	BC	TF430L	FX650	BC+E	FX430	NF656	NF436			
207 CC		07		EFB656	EFB436		TF650L	BC	TF430L	FX650	BC+E	FX430	NF656	NF436			
207 SW		07		EFB656	EFB436	EX300	TF650L	BC	TF430L	FX650	BC+E	FX430	NF656	NF436			
207 Van		07		EFB656	EFB436		TF650L	BC	TF430L	FX650	BC+E	FX430	NF656	NF436			
208		12		EFB6518L	EFB4018L	EX353	TF650L	BC	TF400L	FX650	BC	FX400	NF659	NF409			
304		69	79	EF350	EF350		TF350L	A/D	TF350L	FX350	A/D	FX350	NF350	NF350	T350	T350	
		70	80	EF350	EF350		TF350L	A/D	TF350L	FX350	A/D	FX350	NF350	NF350	T350	T350	
		70	75	EF350	EF350		TF350L	A/D	TF350L	FX350	A/D	FX350	NF350	NF350	T350	T350	
		70	76	EF350	EF350		TF350L	A/D	TF350L	FX350	A/D	FX350	NF350	NF350	T350	T350	
305		77	90	EF400	EF400		TF400L	A/D	TF400L	FX400	A/D	FX400	NF400	NF400	T400	T400	
		80	88	EF400	EF400		TF400L	A/D	TF400L	FX400	A/D	FX400	NF400	NF400	T400	T400	
306		93	01	EF550	EF500		TF550L	A/D	TF500L	FX550	A/D	FX500	NF550	NF500	T550	T500	
		93	01	EF550	EF500	EF550	TF550L	A/D	TF500L	FX550	A/D	FX500	NF550	NF500	T550	T500	T550
		97	02	EF550	EF500	EX404	TF550L	A/D	TF500L	FX550	A/D	FX500	NF550	NF500	T550	T500	
		94	02	EF550	EF500		TF550L	A/D	TF500L	FX550	A/D	FX500	NF550	NF500	T550	T500	
307		00	04	EF700	EF650	EX353	TF700L	A/D	TF650R	FX700	A/D	FX650	NF700	NF650	T700	T650	
		05	07	EFB7017L	EFB6517R	EX353	TF700L	BC	TF650R	FX700	BC	FX650	NF707	NF657			
		02	04	EF700	EF650	EX353	TF700L	A/D	TF650R	FX700	A/D	FX650	NF700	NF650	T700	T650	
		05	08	EFB7017L	EFB6517R	EX353	TF700L	BC	TF650R	FX700	BC	FX650	NF707	NF657			
		03		EFB7017L	EFB6517R		TF700L	BC	TF650R	FX700	BC	FX650	NF707	NF657			
308		08	13	EFB7518L	EFB6518R	EX300	TF750L	BC		FX750	BC	FX650	NF759	NF659			





...PEUGEOT

...308	14		EFB6018L	EFB4518L	EX230	TF600L	BC	TF450L	FX600	BC	FX450	NF609	NF459				
308 CC	09		EFB7518L	EFB6518R		TF750L	BC	TF650R	FX750	BC	FX650	NF759	NF659				
308 SW	08	13	EFB7518L	EFB6518R	EX282	TF750L	BC		FX750	BC	FX650	NF759	NF659				
	14		EFB6018L	EFB4518L	EX308	TF600L	BC	TF450L	FX600	BC	FX450	NF609	NF459				
309	85	93	EF450	EF450	EF450	TF450L	A/D	TF450L	FX450	A/D	FX450	NF450	NF450	T450	T450	T450	
404	63	71	EF280	EF280										T280	T280		
	63	68	EF280	EF280										T280	T280		
405	87	95	EF553	EF553													
	87	96	EF553	EF553	EF330											T330	
406	95	04	EF600	EF550								NF600	NF550				
	96	04	EF600	EF550	EX354							NF600	NF550				
	97	04	EF650	EF500								NF650	NF500				
407	04	09	EFB706	EFB706					FX700	BC+E	FX700	NF706	NF706				
	05	09	EFB706	EFB706					FX700	BC+E	FX700	NF706	NF706				
407 SW	04	09	EFB706	EFB706	EX282				FX700	BC+E	FX700	NF706	NF706				
504	68	86	EF400	EF400		TF400L	A/D	TF400L	FX400	A/D	FX400	NF400	NF400	T400	T400		
	71	86	EF400	EF400	EF400	TF400L	A/D	TF400L	FX400	A/D	FX400	NF400	NF400	T400	T400	T400	
	74	84	EF400	EF400		TF400L	A/D	TF400L	FX400	A/D	FX400	NF400	NF400	T400	T400		
	74	84	EF400	EF400		TF400L	A/D	TF400L	FX400	A/D	FX400	NF400	NF400	T400	T400		
504 Van	80	89	EF400	EF400		TF400L	A/D	TF400L	FX400	A/D	FX400	NF400	NF400	T400	T400		
505	79	93	EF450	EF450		TF450L	A/D	TF450L	FX450	A/D	FX450	NF450	NF450	T450	T450		
	82	93	EF450	EF450	EF450	TF450L	A/D	TF450L	FX450	A/D	FX450	NF450	NF450	T450	T450	T450	
508	10		EFB6518L	EFB6518R		TF650L	BC	TF650R	FX650	BC	FX650	NF659	NF659				
508 SW	10		EFB6518L	EFB6518R	EX300	TF650L	BC	TF650R	FX650	BC	FX650	NF659	NF659				
604	77	87	EF450	EF450		TF450L	A/D	TF450L	FX450	A/D	FX450	NF450	NF450	T450	T450		
605	89	99	EF550	EF550		TF550L	A/D	TF550L	FX550	A/D	FX550	NF550	NF550	T550	T550		
607	00		EF641	EF521													
806	94	02	EF650	EF500	EF400	TF650L	A/D	TF500L	FX650	A/D	FX500	NF650	NF500	T650	T500	T400	
807	02	06	EF653	EF653	EX353												
	06		EF650	EF650	EX353	TF650L	A/D	TF650L	FX650	A/D	FX650	NF650	NF650	T650	T650		
1007	05		EF600	EF450	EX300	TF600L	A/D	TF450L	FX600	A/D	FX450	NF600	NF450	T600	T450		
2008	13		EFB6518L	EFB4018L	EX282	TF650L	BC	TF400L	FX650	BC	FX400	NF659	NF409				
3008	09		EFB8018L	EFB6518R	EX300	TF800L	BC	TF650R	FX800	BC	FX650	NF809	NF659				
4007	07		HF600	HF530	EX306	TF600L	A/D	TF530L	FX600	A/D	FX530	NF600	NF530				
4008	12		HF600	HF530	EX252	TF600L	A/D	TF530L	FX600	A/D	FX530	NF600	NF530				
5008	09		EFB8018L	EFB6518R	EX282	TF800L	BC	TF650R	FX800	BC	FX650	NF809	NF659				
BIPPER	08		EFB6514L	EFB4514L		TF650L	F	TF450L	FX650	E1		NF6514	NF4514				
BIPPER Van	08		EFB6514L	EFB4514L		TF650L	F	TF450L	FX650	E1		NF6514	NF4514				
BOXER	94	06	EF550	EF550		TF550L	A/D	TF550L	FX550	A/D	FX550	NF550	NF550	T550	T550		
	06		EFB6518L	EFB5318L		TF650L	BC	TF550L	FX650	BC	FX550	NF659	NF539				
EXPERT	MPV	95	06	EF700	EF500	EF400						NF700	NF500	T700	T500	T400	
		07		EF700	EF500	EF400	TF700L	A/D	TF500L	FX700	A/D	FX500	NF700	NF500	T700	T500	T400
EXPERT Van		96	06	EF700	EF500							NF700	NF500	T700	T500		
		07		EF700	EF500		TF700L	A/D	TF500L	FX700	A/D	FX500	NF700	NF500	T700	T500	
ION		10		HF700		EX306	TF700L	A/D	FX700	A/D		NF700					
J5		81	94	EF500	EF500		TF500L	A/D	TF500L	FX500	A/D	FX500	NF500	NF500	T500	T500	



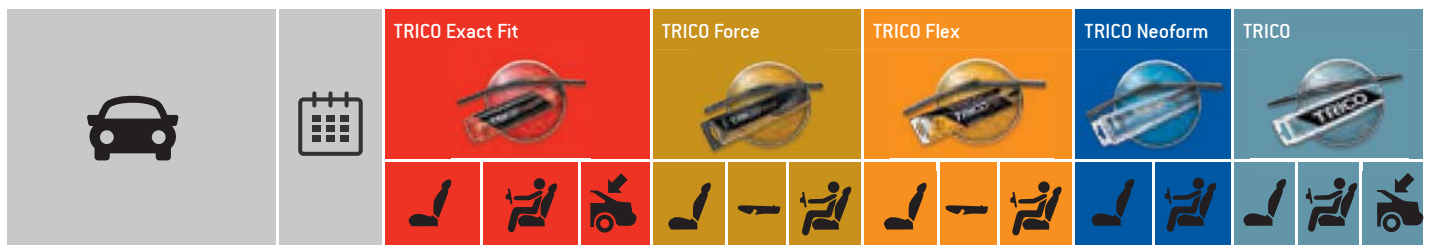

...PEUGEOT

J5 Van	81	94	EF500	EF500		TF500L	A/D	TF500L	FX500	A/D	FX500	NF500	NF500	T500	T500	
J7	68	80	EF400	EF400		TF400L	A/D	TF400L	FX400	A/D	FX400	NF400	NF400	T400	T400	
J9	80	87	EF400	EF400		TF400L	A/D	TF400L	FX400	A/D	FX400	NF400	NF400	T400	T400	
PARTNER MPV	96	05	EF550	EF550	EF400	TF550L	A/D	TF550L	FX550	A/D	FX550	NF550	NF550	T550	T550	T400
PARTNER Tepee	06		EFB6518L	EFB4018L	EX353	TF650L	BC	TF400L	FX650	BC	FX400	NF659	NF409			
PARTNER Van	96	05	EF550	EF550	EF400	TF550L	A/D	TF550L	FX550	A/D	FX550	NF550	NF550	T550	T550	T400
	06		EFB6518L	EFB4018L		TF650L	BC	TF400L	FX650	BC	FX400	NF659	NF409			
RCZ	10		EFB6518L	EFB6518R		TF650L	BC	TF650R	FX650	BC	FX650	NF659	NF659			



PIAGGIO

PORTER	93		EF380	EF380		TF350L	A/D	TF350L	FX350	A/D	FX350	NF350	NF350	T380	T380	
--------	----	--	-------	-------	--	--------	-----	--------	-------	-----	-------	-------	-------	------	------	--





PININFARINA

SPIDEREUROPA	82	85	EF330	EF330										T330	T330	
--------------	----	----	-------	-------	--	--	--	--	--	--	--	--	--	------	------	--

PLYMOUTH

ACCLAIM	88	95	EF450	EF450		TF450L	A/D	TF450L	FX450	A/D	FX450	NF450	NF450	T450	T450	
BREEZE	95	01	EF550	EF550		TF550L	A/D	TF550L	FX550	A/D	FX550	NF550	NF550	T550	T550	
NEON 	94	99	EF530	EF450		TF530L	A/D	TF450L	FX530	A/D	FX450	NF530	NF450	T530	T450	
	99		EF550	EF480		TF550L	A/D	TF480L	FX550	A/D	FX480	NF550	NF480	T550	T480	
	94	99	EF530	EF450		TF530L	A/D	TF450L	FX530	A/D	FX450	NF530	NF450	T530	T450	
SUNDANCE 	86	94	EF450	EF450		TF450L	A/D	TF450L	FX450	A/D	FX450	NF450	NF450	T450	T450	
	86	94	EF450	EF450		TF450L	A/D	TF450L	FX450	A/D	FX450	NF450	NF450	T450	T450	
VOYAGER 	89	01	EF700	EF700	EF400	TF700L	A/D	TF700L	FX700	A/D	FX700	NF700	NF700	T700	T700	T400

PONTIAC

AZTEK	00	05	EF600	EF600		TF600L	A/D	TF600L	FX600	A/D	FX600	NF600	NF600	T600	T600	
BONNEVILLE	86		EF480	EF480		TF480L	A/D	TF480L	FX480	A/D	FX480	NF480	NF480	T480	T480	
FIREBIRD 	81	97	EF450	EF450		TF450L	A/D	TF450L	FX450	A/D	FX450	NF450	NF450	T450	T450	
	93		EF450	EF450		TF450L	A/D	TF450L	FX450	A/D	FX450	NF450	NF450	T450	T450	
G6	04		EFB6017L	EFB5317L		TF600L	BC	TF530L	FX600	BC	FX530	NF607	NF537			
GRAND PRIX 	96		EF550	EF550		TF550L	A/D	TF550L	FX550	A/D	FX550	NF550	NF550	T550	T550	
	96		EF500	EF500		TF500L	A/D	TF500L	FX500	A/D	FX500	NF500	NF500	T500	T500	
MONTANA	98	05	EF600	EF600	EF400	TF600L	A/D	TF600L	FX600	A/D	FX600	NF600	NF600	T600	T600	T400
PHOENIX 	79	81	EF450	EF450		TF450L	A/D	TF450L	FX450	A/D	FX450	NF450	NF450	T450	T450	
	79	81	EF450	EF450		TF450L	A/D	TF450L	FX450	A/D	FX450	NF450	NF450	T450	T450	
SOLSTICE	05		EF400	EF500		TF400L	A/D	TF500L	FX400	A/D	FX500	NF400	NF500	T400	T500	
SUNBIRD	75	81	EF400	EF400		TF400L	A/D	TF400L	FX400	A/D	FX400	NF400	NF400	T400	T400	
SUNFIRE 	94	02	EF500	EF430		TF500L	A/D	TF430L	FX500	A/D	FX430	NF500	NF430	T500	T430	
	94	02	EF500	EF430		TF500L	A/D	TF430L	FX500	A/D	FX430	NF500	NF430	T500	T430	
TORRENT	04		EF600	EF480	EF380	TF600L	A/D	TF480L	FX600	A/D	FX480	NF600	NF480	T600	T480	T380
TRANS SPORT	89	97	EF600	EF600		TF600L	A/D	TF600L	FX600	A/D	FX600	NF600	NF600	T600	T600	
	97		EF600	EF600	EF400	TF600L	A/D	TF600L	FX600	A/D	FX600	NF600	NF600	T600	T600	T400

PORSCHE

911 	63	93	EF330	EF330	EF400									T330	T330	T400
	93	97	EF380	EF450		TF350L	A/D	TF450L	FX350	A/D	FX450	NF350	NF450	T380	T450	
	97	11	EF550	EF550	EF550	TF550L	A/D	TF550L	FX550	A/D	FX550	NF550	NF550	T550	T550	T550
	11		EFB5317L	EFB5317L		TF530L	BC	TF530L	FX530	BC	FX530	NF5313	NF5313			
	82	89	EF330	EF330	EF400									T330	T330	T400
	86	94	EF330	EF330										T330	T330	



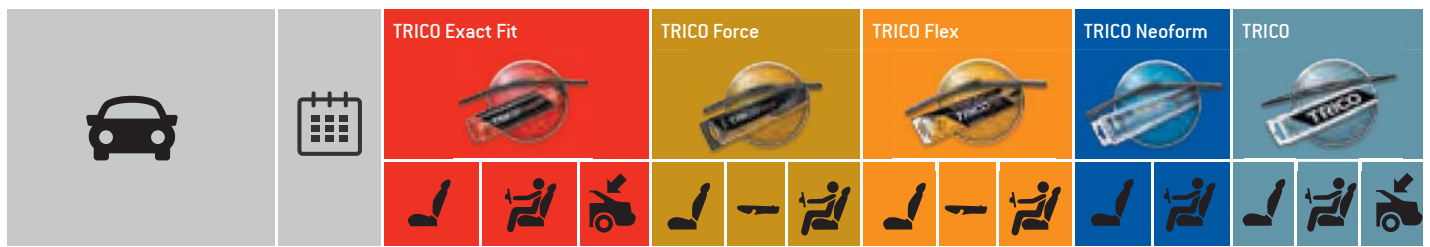

...PORSCHE

...911		94	97	EF380	EF450		TF350L	A/D	TF450L	FX350	A/D	FX450	NF350	NF450	T380	T450	
		98	11	EF550	EF550		TF550L	A/D	TF550L	FX550	A/D	FX550	NF550	NF550	T550	T550	
		12		EFB5317L	EFB5317L		TF530L	BC	TF530L	FX530	BC	FX530	NF5313	NF5313			
912		65	69	EF330	EF330										T330	T330	
		65	70	EF330	EF330										T330	T330	
914		69	76	EF330	EF330										T330	T330	
924		75	89	EF450	EF450	EF500	TF450L	A/D	TF450L	FX450	A/D	FX450	NF450	NF450	T450	T450	T500
928		77	84	EF450	EF450		TF450L	A/D	TF450L	FX450	A/D	FX450	NF450	NF450	T450	T450	
		85	95	EF480	EF480		TF480L	A/D	TF480L	FX480	A/D	FX480	NF480	NF480	T480	T480	
944		81	91	EF450	EF450	EF500	TF450L	A/D	TF450L	FX450	A/D	FX450	NF450	NF450	T450	T450	T500
		88	91	EF450	EF450		TF450L	A/D	TF450L	FX450	A/D	FX450	NF450	NF450	T450	T450	
968		91	95	EF450	EF450		TF450L	A/D	TF450L	FX450	A/D	FX450	NF450	NF450	T450	T450	
		91	95	EF450	EF450		TF450L	A/D	TF450L	FX450	A/D	FX450	NF450	NF450	T450	T450	
BOXSTER		96	11	EF550	EF550		TF550L	A/D	TF550L	FX550	A/D	FX550	NF550	NF550	T550	T550	
		12		EFB5317L	EFB5317L		TF530L	BC	TF530L	FX530	BC	FX530	NF5313	NF5313			
CARRERA GT		03	11	EF550	EF550		TF550L	A/D	TF550L	FX550	A/D	FX550	NF550	NF550	T550	T550	
CAYENNE		02	10	EFB656	EFB656	EX330	TF650L	BC	TF650L	FX650	BC+E	FX650	NF656	NF656			
		10		EFB656	EFB656	EX356	TF650L	BC	TF650L	FX650	BC+E	FX650	NF656	NF656			
CAYMAN		05	11	EF550	EF550		TF550L	A/D	TF550L	FX550	A/D	FX550	NF550	NF550	T550	T550	
		12		EFB5317L	EFB5317L		TF530L	BC	TF530L	FX530	BC	FX530	NF5313	NF5313			
MACAN		14		EFB6017L	EFB5017L		TF600L	BC	TF500L	FX600	BC	FX500	NF6013	NF5013			
PANAMERA		09	13	EF580	EF530		TF550L	A/D	TF530L	FX550	A/D	FX530	NF550	NF530	T580	T530	
		14		EFB6017L	EFB5017L		TF600L	BC	TF500L	FX600	BC	FX500	NF6013	NF5013			

PROTON

AEROBACK		88	96	EF480*	EF480*	EF400									T480*	T480*	T400
GEN 2		04		EF550	EF430	EF450	TF550L	A/D	TF430L	FX550	A/D	FX430	NF550	NF430	T550	T430	T450
IMPIAN		01		EF500	EF430		TF500L	A/D	TF430L	FX500	A/D	FX430	NF500	NF430	T500	T430	
JUMBUCK		02		EF500	EF430		TF500L	A/D	TF430L	FX500	A/D	FX430	NF500	NF430	T500	T430	
PERSONA		94		EF500	EF430	EF350	TF500L	A/D	TF430L	FX500	A/D	FX430	NF500	NF430	T500	T430	T350
		94		EF500	EF430	EF350	TF500L	A/D	TF430L	FX500	A/D	FX430	NF500	NF430	T500	T430	T350
SALOON		91	96	EF450*	EF450*										T450*	T450*	
SATRIA		96		EF500	EF430	EF350	TF500L	A/D	TF430L	FX500	A/D	FX430	NF500	NF430	T500	T430	T350
SATRIA NEO		96		EF500	EF430		TF500L	A/D	TF430L	FX500	A/D	FX430	NF500	NF430	T500	T430	T350
SAVVY		05		EF550	EF430	EX306	TF550L	A/D	TF430L	FX550	A/D	FX430	NF550	NF430	T550	T430	
WIRA		00		EF500	EF430	EF350	TF500L	A/D	TF430L	FX500	A/D	FX430	NF500	NF430	T500	T430	T350
		00		EF500	EF430	EF350	TF500L	A/D	TF430L	FX500	A/D	FX430	NF500	NF430	T500	T430	T350

PUCH

G-MODELL		79	92	EF400	EF400	EF380	TF400L	A/D	TF400L	FX400	A/D	FX400	NF400	NF400	T400	T400	T380
----------	--	----	----	-------	-------	-------	--------	-----	--------	-------	-----	-------	-------	-------	------	------	------

RELIANT

FOX		82	90	EF380	EF380		TF350L	A/D	TF350L	FX350	A/D	FX350	NF350	NF350	T380	T380	
KITTEN		75	83	EF380	EF380	EF380	TF350L	A/D	TF350L	FX350	A/D	FX350	NF350	NF350	T380	T380	T380
		75	83	EF380	EF380	EF380	TF350L	A/D	TF350L	FX350	A/D	FX350	NF350	NF350	T380	T380	T380
SCIMITAR		68	86	EF350	EF350		TF350L	A/D	TF350L	FX350	A/D	FX350	NF350	NF350	T350	T350	
		80	85	EF450	EF450		TF450L	A/D	TF450L	FX450	A/D	FX450	NF450	NF450	T450	T450	
		85	90	EF500	EF500		TF500L	A/D	TF500L	FX500	A/D	FX500	NF500	NF500	T500	T500	
SCIMITAR SABRE		92	94	EF500	EF500		TF500L	A/D	TF500L	FX500	A/D	FX500	NF500	NF500	T500	T500	



		TRICO Exact Fit			TRICO Force			TRICO Flex			TRICO Neoform		TRICO	

RENAULT

4		62	93	EF280	EF280										T280	T280	
4 Van		66	93	EF280	EF280										T280	T280	
5		72	85												T450	T450	T450
8		62	72	EF280	EF280										T280	T280	
9		81	89	EF400	EF400		TF400L	A/D	TF400L	FX400	A/D	FX400	NF400	NF400	T400	T400	
11		83	88	EF400	EF400		TF400L	A/D	TF400L	FX400	A/D	FX400	NF400	NF400	T400	T400	
11 Van		83	88	EF400	EF400		TF400L	A/D	TF400L	FX400	A/D	FX400	NF400	NF400	T400	T400	
12		69	80	EF400	EF400		TF400L	A/D	TF400L	FX400	A/D	FX400	NF400	NF400	T400	T400	
		70	80	EF400	EF400	EF330	TF400L	A/D	TF400L	FX400	A/D	FX400	NF400	NF400	T400	T400	T330
14		76	83	EF400	EF400	EF400	TF400L	A/D	TF400L	FX400	A/D	FX400	NF400	NF400	T400	T400	T400
15		72	80	EF430	EF430		TF430L	A/D	TF430L	FX430	A/D	FX430	NF430	NF430	T430	T430	
17		72	80	EF430	EF430		TF430L	A/D	TF430L	FX430	A/D	FX430	NF430	NF430	T430	T430	
18		78	93	EF400	EF400		TF400L	A/D	TF400L	FX400	A/D	FX400	NF400	NF400	T400	T400	
		79	93	EF400	EF400		TF400L	A/D	TF400L	FX400	A/D	FX400	NF400	NF400	T400	T400	
18 Van		79	86	EF400	EF400		TF400L	A/D	TF400L	FX400	A/D	FX400	NF400	NF400	T400	T400	
19		88	03	EF500	EF500		TF500L	A/D	TF500L	FX500	A/D	FX500	NF500	NF500	T500	T500	
		88	95	EF500	EF500	EF500	TF500L	A/D	TF500L	FX500	A/D	FX500	NF500	NF500	T500	T500	T500
		91	92	EF500	EF500		TF500L	A/D	TF500L	FX500	A/D	FX500	NF500	NF500	T500	T500	
19 Van		88	95	EF500	EF500		TF500L	A/D	TF500L	FX500	A/D	FX500	NF500	NF500	T500	T500	
20		75	83	EF450	EF450		TF450L	A/D	TF450L	FX450	A/D	FX450	NF450	NF450	T450	T450	
21		86	94	EF500	EF500		TF500L	A/D	TF500L	FX500	A/D	FX500	NF500	NF500	T500	T500	
		89	94	EF500	EF500		TF500L	A/D	TF500L	FX500	A/D	FX500	NF500	NF500	T500	T500	
		86	95	EF500	EF500	EF450	TF500L	A/D	TF500L	FX500	A/D	FX500	NF500	NF500	T500	T500	T450
21 Van		86	95	EF500	EF500	EF450	TF500L	A/D	TF500L	FX500	A/D	FX500	NF500	NF500	T500	T500	T450
25		84	93	EF550	EF550		TF550L	A/D	TF550L	FX550	A/D	FX550	NF550	NF550	T550	T550	
30		75	86	EF450	EF450	EF400	TF450L	A/D	TF450L	FX450	A/D	FX450	NF450	NF450	T450	T450	T400
AVANTIME		01	03	EF653	EF453	EX404											
CAPTUR		13		EFB6514L	EFB3514L	EX282	TF650L	F	TF350L	FX650	E1	FX350	NF6514				
CLIO		90	95	EF450	EF450	EF400	TF450L	A/D	TF450L	FX450	A/D	FX450	NF450	NF450	T450	T450	
		96	98	EF500	EF500	EX404	TF500L	A/D	TF500L	FX500	A/D	FX500	NF500	NF500	T500	T500	
		98	05	EF530	EF450	EX300	TF530L	A/D	TF450L	FX530	A/D	FX450	NF530	NF450	T530	T450	
		05	12	EFB6014L	EFB4014L	EX353	TF600L	F	TF400L	FX600	E1	FX400	NF6014	NF4014			
		13		EFB6514L	EFB3514L	EX253	TF650L	F	TF350L	FX650	E1	FX350	NF6514				
		08	12	EFB6014L	EFB4014L	EX300	TF600L	F	TF400L	FX600	E1	FX400	NF6014	NF4014			
		13		EFB6514L	EFB3514L	EX253	TF650L	F	TF350L	FX650	E1	FX350	NF6514				
CLIO CAMPUS		05	12	EF530	EF450	EX300	TF530L	A/D	TF450L	FX530	A/D	FX450	NF530	NF450	T530	T450	
CLIO Van		91	95	EF450	EF450	EX404	TF450L	A/D	TF450L	FX450	A/D	FX450	NF450	NF450	T450	T450	
		96	98	EF500	EF500	EX404	TF500L	A/D	TF500L	FX500	A/D	FX500	NF500	NF500	T500	T500	
		98	05	EF530	EF450	EX300	TF530L	A/D	TF450L	FX530	A/D	FX450	NF530	NF450	T530	T450	
ESPACE		84	92			EF400									T550	T550	T400
		91	96	EF603	EF553	EF400											T400
		96	02	EF603	EF553	EX404											
		02	14	EFB756	EFB656	EX353	TF700L	BC	TF650R	FX700	BC+E	FX650	NF756	NF656			
		15		EFB7518L	EFB7018R	EX308	TF750L	BC	TF700R	FX750	BC	FX700	NF759	NF709			
ESTAFETTE		62	81	EF280	EF280										T280	T280	
FLUENCE		10		EFB6014L	EFB4014L		TF600L	F	TF400L	FX600	E1	FX400	NF6014	NF4014			

				TRICO Exact Fit			TRICO Force			TRICO Flex			TRICO Neoform		TRICO	
--	--	--	--	------------------------	--	--	--------------------	--	--	-------------------	--	--	----------------------	--	--------------	--

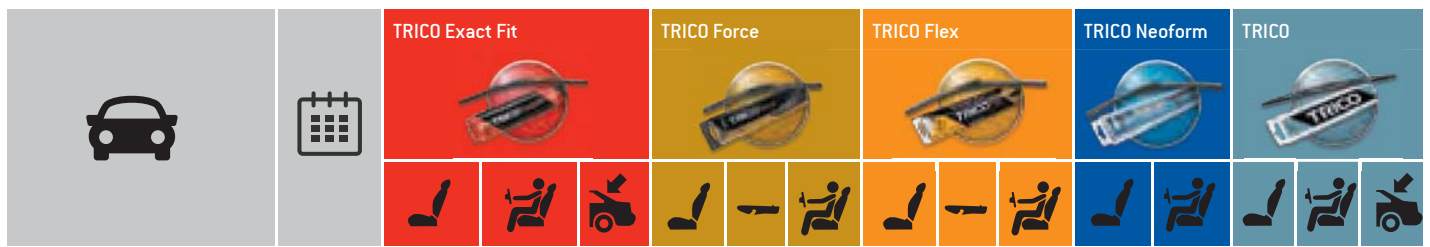

...RENAULT

FUEGO	80	92	EF450	EF450		TF450L	A/D	TF450L	FX450	A/D	FX450	NF450	NF450	T450	T450	
GRAND MODUS	07		EFB706	EFB606	EX300	TF700L	BC	TF600R	FX700	BC+E	FX600	NF706	NF606			
GRAND SCÉNIC	03	04	EFB654	EFB554	EX251							NF654	NF554			
	05	09	EFB6514L	EFB5514L	EX251	TF650L	F	TF550L	FX650	E1	FX550	NF6514	NF5514			
	10		EFB7514L	EFB6514R	EX308	TF750L	F	TF650R	FX750	E1	FX650	NF7514	NF6514			
KADJAR	15		HF650	HF430	EX230	TF650L	A/D	TF430L	FX650	A/D	FX430	NF650	NF430			
KANGOO	MPV	97	07	EF500	EF500	EX404	TF500L	A/D	TF500L	FX500	A/D	FX500	NF500	NF500	T500	T500
		08		EFB5514L	EFB5014L		TF550L	F	TF500L	FX550	E1	FX500	NF5514	NF4514		
KANGOO Van		97	07	EF500	EF500		TF500L	A/D	TF500L	FX500	A/D	FX500	NF500	NF500	T500	T500
		08		EFB5514L	EFB5014L		TF550L	F	TF500L	FX550	E1	FX500	NF5514	NF4514		
KOLEOS		08		EFB6017L	EFB4817L		TF600L	BC	TF480L	FX600	BC	FX480	NF607	NF487		
LAGUNA		93	01	EF600	EF450		TF600L	A/D	TF450L	FX600	A/D	FX450	NF600	NF450	T600	T450
		01	06	EF600	EF500	EX500	TF600L	A/D	TF500L	FX600	A/D	FX500	NF600	NF500	T600	T500
		07		EFB6514L	EFB4014L	EF480	TF650L	F	TF400L	FX650	E1	FX400	NF6514	NF4014		T480
		95	01	EF600	EF450		TF600L	A/D	TF450L	FX600	A/D	FX450	NF600	NF450	T600	T450
		01	06	EF600	EF500	EX353	TF600L	A/D	TF500L	FX600	A/D	FX500	NF600	NF500	T600	T500
		07		EFB6514L	EFB4014L	EX357	TF650L	F	TF400L	FX650	E1	FX400	NF6514	NF4014		
		08		EFB6514L	EFB4014L		TF650L	F	TF400L	FX650	E1	FX400	NF6514	NF4014		
LATITUDE		11		HF600	HF400		TF600L	A/D	TF400L	FX600	A/D	FX400	NF600	NF400		
LOGAN		04		EF500	EF500		TF500L	A/D	TF500L	FX500	A/D	FX500	NF500	NF500	T500	T500
		07		EF500	EF500		TF500L	A/D	TF500L	FX500	A/D	FX500	NF500	NF500	T500	T500
MASTER		80	98	EF500	EF500		TF500L	A/D	TF500L	FX500	A/D	FX500	NF500	NF500	T500	T500
		98	09	EF603	EF603											
		10		EF650	EF650		TF650L	A/D	TF650L	FX650	A/D	FX650	NF650	NF650	T650	T650
MEGANE		96	03	EF550	EF500		TF550L	A/D	TF500L	FX550	A/D	FX500	NF550	NF500	T550	T500
		03	05	EF600	EF450		TF600L	A/D	TF450L	FX600	A/D	FX450	NF600	NF450	T600	T450
		05	08	EFB6014L	EFB4514L		TF600L	F	TF450L	FX600	E1	FX450	NF6014	NF4514		
		09		EFB6014L	EFB4014L		TF600L	F	TF400L	FX600	E1	FX400	NF6014	NF4014		
		96	01	EF550	EF500	EF500	TF550L	A/D	TF500L	FX550	A/D	FX500	NF550	NF500	T550	T500
		02	05	EF600	EF450	EX230	TF600L	A/D	TF450L	FX600	A/D	FX450	NF600	NF450	T600	T450
		06	07	EFB6014L	EFB4514L	EX230	TF600L	F	TF450L	FX600	E1	FX450	NF6014	NF4514		
		08		EFB6014L	EFB4014L	EX357	TF600L	F	TF400L	FX600	E1	FX400	NF6014	NF4014		
		99	03	EF550	EF500	EX353	TF550L	A/D	TF500L	FX550	A/D	FX500	NF550	NF500	T550	T500
		03	05	EF600	EF450	EX251	TF600L	A/D	TF450L	FX600	A/D	FX450	NF600	NF450	T600	T450
		06	07	EFB6014L	EFB4514L	EX251	TF600L	F	TF450L	FX600	E1	FX450	NF6014	NF4514		
		08		EFB6014L	EFB4014L	EX353	TF600L	F	TF400L	FX600	E1	FX400	NF6014	NF4014		
		96	03	EF550	EF500		TF550L	A/D	TF500L	FX550	A/D	FX500	NF550	NF500	T550	T500
		08		EFB6014L	EFB4014L	EX357	TF600L	F	TF400L	FX600	E1	FX400	NF6014	NF4014		
		96	03	EF550	EF500		TF550L	A/D	TF500L	FX550	A/D	FX500	NF550	NF500	T550	T500
		10		EFB6014L	EFB4014L		TF600L	F	TF400L	FX600	E1	FX400	NF6014	NF4014		
MEGANE SCENIC		97	99	EF600	EF400	EX404	TF600L	A/D	TF400L	FX600	A/D	FX400	NF600	NF400	T600	T400
MODUS		04	05	EFB706	EFB606	EX251	TF700L	BC	TF600R	FX700	BC+E	FX600	NF706	NF606		
		06		EFB706	EFB606	EX300	TF700L	BC	TF600R	FX700	BC+E	FX600	NF706	NF606		
RAPID		85	98	EF450	EF450		TF450L	A/D	TF450L	FX450	A/D	FX450	NF450	NF450	T450	T450
RODEO		70	81	EF330	EF330										T330	T330
SAFRANE		92	96		EF600	EF550									T600	T550



		TRICO Exact Fit			TRICO Force			TRICO Flex			TRICO Neoform		TRICO	

...RENAULT

...SAFRANE	96	00	EF600	EF600	EF550	TF600L	A/D	TF600L	FX600	A/D	FX600	NF600	NF600	T600	T600	T550
SCÉNIC	99	03	EF600	EF400	EX404	TF600L	A/D	TF400L	FX600	A/D	FX400	NF600	NF400	T600	T400	
		03	04	EFB654	EFB554	EX251						NF654	NF554			
		05	10	EFB6514L	EFB5514L	EX251	TF650L	F	TF550L	FX650	E1	FX550	NF6514	NF5514		
			10	EFB7514L	EFB6514R	EX308	TF750L	F	TF650R	FX750	E1	FX650	NF7514	NF6514		
SUPER 5	84	96	EF450	EF450	EF400	TF450L	A/D	TF450L	FX450	A/D	FX450	NF450	NF450	T450	T450	T400
TRAFIC	80	94	EF450	EF450		TF450L	A/D	TF450L	FX450	A/D	FX450	NF450	NF450	T450	T450	
		89	01	EF500	EF500		TF500L	A/D	TF500L	FX500	A/D	FX500	NF500	NF500	T500	T500
		01	13	EF600	EF530	EX404	TF600L	A/D	TF530L	FX600	A/D	FX530	NF600	NF530	T600	T530
			14	EFB6518L	EFB4818L	EFB4017L	TF650L	BC	TF480L	FX650	BC	FX480	NF659	NF489		
			14	EFB6518L	EFB4818L	EX404x2	TF650L	BC	TF480L	FX650	BC	FX480	NF659	NF489		
TWINGO	93	06	EF650		EX301	TF650L	A/D		FX650	A/D		NF650		T650		
		07	14	EFB6018L	EFB4018L	EX300	TF600L	A/D	TF400L	FX600	A/D	FX400	NF609	NF409		
			14	EFB5014L	EFB3514L	EX357	TF500L	F	TF350L	FX500	E1	FX350				
TWINGO Van	93	06	EF650			TF650L	A/D		FX650	A/D		NF650		T650		
TWIZY	12		EF450			TF450L	A/D		FX450	A/D		NF450		T450		
VEL SATIS	02	09	EFB756	EFB656	EX300	TF750L	BC	TF650R	FX750	BC+E	FX650	NF756	NF656			
WIND	10		EFB6018L	EFB4018L		TF600L	BC	TF400L	FX600	BC	FX400	NF609	NF409			
ZOE	12		EFB6518L	EFB3518L	EX282	TF600L	BC	TF350L	FX600	BC	FX350	NF609	NF359			

ROLLS-ROYCE

SILVER SERAPH	98	02	EF600	EF600		TF600L	A/D	TF600L	FX600	A/D	FX600	NF600	NF600	T600	T600	
---------------	----	----	-------	-------	--	--------	-----	--------	-------	-----	-------	-------	-------	------	------	--

ROVER

25	99	04	EF450	EF450	EF450	TF450L	A/D	TF450L	FX450	A/D	FX450	NF450	NF450	T450	T450	T450	
		04	05	EF450	EF450	EX404	TF450L	A/D	TF450L	FX450	A/D	FX450	NF450	NF450	T450	T450	
45	00	05	EF500	EF450		TF500L	A/D	TF450L	FX500	A/D	FX450	NF500	NF450	T500	T450		
		00	05	EF500	EF450	EF450	TF500L	A/D	TF450L	FX500	A/D	FX450	NF500	NF450	T500	T450	T450
75	99	05	EF550	EF550		TF550L	A/D	TF550L	FX550	A/D	FX550	NF550	NF550	T550	T550		
		01	05	EF550	EF550	EX357	TF550L	A/D	TF550L	FX550	A/D	FX550	NF550	NF550	T550	T550	
100	90	98	EF400	EF400	EF380	TF400L	A/D	TF400L	FX400	A/D	FX400	NF400	NF400	T400	T400	T380	
		94	98	EF400	EF400		TF400L	A/D	TF400L	FX400	A/D	FX400	NF400	NF400	T400	T400	
200	85	89	EF450	EF450		TF450L	A/D	TF450L	FX450	A/D	FX450	NF450	NF450	T450	T450		
		89	00	EF450	EF450	EF450	TF450L	A/D	TF450L	FX450	A/D	FX450	NF450	NF450	T450	T450	T450
		92	99	EF450	EF450		TF450L	A/D	TF450L	FX450	A/D	FX450	NF450	NF450	T450	T450	
400	90	95	EF450	EF450		TF450L	A/D	TF450L	FX450	A/D	FX450	NF450	NF450	T450	T450		
		95	00	EF500	EF450		TF500L	A/D	TF450L	FX500	A/D	FX450	NF500	NF450	T500	T450	
		95	00	EF500	EF450	EF450	TF500L	A/D	TF450L	FX500	A/D	FX450	NF500	NF450	T500	T450	T450
		93	98	EF450	EF450	EF350	TF450L	A/D	TF450L	FX450	A/D	FX450	NF450	NF450	T450	T450	T350
600	93	99	EF550	EF500		TF550L	A/D	TF500L	FX550	A/D	FX500	NF550	NF500	T550	T500		
800	86	91	EF480	EF480		TF480L	A/D	TF480L	FX480	A/D	FX480	NF480	NF480	T480	T480		
		92	99	EF500	EF500		TF500L	A/D	TF500L	FX500	A/D	FX500	NF500	NF500	T500	T500	
		86	91	EF480	EF480	EF480	TF480L	A/D	TF480L	FX480	A/D	FX480	NF480	NF480	T480	T480	T480
		92	99	EF500	EF500	EF500	TF500L	A/D	TF500L	FX500	A/D	FX500	NF500	NF500	T500	T500	T500
		92	99	EF500	EF500		TF500L	A/D	TF500L	FX500	A/D	FX500	NF500	NF500	T500	T500	
CABRIOLET	90	99	EF450	EF450		TF450L	A/D	TF450L	FX450	A/D	FX450	NF450	NF450	T450	T450		
CITYROVER	04	05	EF600	EF430		TF600L	A/D	TF430L	FX600	A/D	FX430	NF600	NF430	T600	T430		
COUPE	96	99	EF450	EF450		TF450L	A/D	TF450L	FX450	A/D	FX450	NF450	NF450	T450	T450		

			TRICO Exact Fit			TRICO Force			TRICO Flex			TRICO Neoform		TRICO	
--	--	--	------------------------	--	--	--------------------	--	--	-------------------	--	--	----------------------	--	--------------	--



...ROVER

MAESTRO		90	95	EF500	EF500	EF500	TF500L	A/D	TF500L	FX500	A/D	FX500	NF500	NF500	T500	T500	T500
MINI		91	00	EF280	EF280										T280	T280	
		92	01	EF280	EF280										T280	T280	
MINI-MOKE		87	05	EF280	EF280										T280	T280	
MONTEGO		88	95	EF500	EF500		TF500L	A/D	TF500L	FX500	A/D	FX500	NF500	NF500	T500	T500	
		84	93	EF500	EF500	EF350	TF500L	A/D	TF500L	FX500	A/D	FX500	NF500	NF500	T500	T500	T350
P6		63	76	EF350	EF350		TF350L	A/D	TF350L	FX350	A/D	FX350	NF350	NF350	T350	T350	
SD1		76	86	EF450	EF450		TF450L	A/D	TF450L	FX450	A/D	FX450	NF450	NF450	T450	T450	
STREETWISE		03	05	EF450	EF450	EX404	TF450L	A/D	TF450L	FX450	A/D	FX450	NF450	NF450	T450	T450	

SAAB

9-3		02	07	EF580	EF580		TF550L	A/D	TF550L	FX550	A/D	FX550	NF550	NF550	T580	T580	
		07	12	EFB5517L	EFB5517L		TF550L	BC	TF550L	FX550	BC	FX550	NF557	NF557			
		98	02	EF530	EF530	EF500	TF530L	A/D	TF530L	FX530	A/D	FX530	NF530	NF530	T530	T530	T500
		05	07	EF580	EF580	EX308	TF550L	A/D	TF550L	FX550	A/D	FX550	NF550	NF550	T580	T580	
		07	12	EFB5517L	EFB5517L	EX308	TF550L	BC	TF550L	FX550	BC	FX550	NF557	NF557			
		98	03	EF530	EF530		TF530L	A/D	TF530L	FX530	A/D	FX530	NF530	NF530	T530	T530	
		03	07	EF580	EF580		TF550L	A/D	TF550L	FX550	A/D	FX550	NF550	NF550	T580	T580	
		07	12	EFB5517L	EFB5517L		TF550L	BC	TF550L	FX550	BC	FX550	NF557	NF557			
9-3X		09	12	EFB5517L	EFB5517L	EX282	TF550L	BC	TF550L	FX550	BC	FX550	NF557	NF557			
9-5		97	07	EF580	EF550		TF550L	A/D	TF550L	FX550	A/D	FX550	NF550	NF550	T580	T550	
		08	09	EFB5514L	EFB5514L		TF550L	F	TF550L	FX550	E1	FX550	NF5514	NF5514			
		10	12	HF600	HF530		TF600L	A/D	TF530L	FX600	A/D	FX530	NF600	NF530			
		98	05	EF580	EF550	EX354	TF550L	A/D	TF550L	FX550	A/D	FX550	NF550	NF550	T580	T550	
		08	10	EFB5514L	EFB5514L	EX282	TF550L	F	TF550L	FX550	E1	FX550	NF5514	NF5514			
9-7X		05	12	EF550	EF550	EX282	TF550L	A/D	TF550L	FX550	A/D	FX550	NF550	NF550	T550	T550	
90		84	87	EF380	EF380		TF350L	A/D	TF350L	FX350	A/D	FX350	NF350	NF350	T380	T380	
95		60	78	EF330	EF330										T330	T330	
96		65	80	EF330	EF330										T330	T330	
99		72	84	EF380	EF380		TF350L	A/D	TF350L	FX350	A/D	FX350	NF350	NF350	T380	T380	
		68	84	EF330	EF330										T330	T330	
900		79	93	EF400	EF400		TF400L	A/D	TF400L	FX400	A/D	FX400	NF400	NF400	T400	T400	
		78	94	EF400	EF400	EF400	TF400L	A/D	TF400L	FX400	A/D	FX400	NF400	NF400	T400	T400	T400
		93	98	EF530	EF530	EF500	TF530L	A/D	TF530L	FX530	A/D	FX530	NF530	NF530	T530	T530	T500
		93	98	EF530	EF530		TF530L	A/D	TF530L	FX530	A/D	FX530	NF530	NF530	T530	T530	
		85	94	EF450	EF450		TF450L	A/D	TF450L	FX450	A/D	FX450	NF450	NF450	T450	T450	
		93	98	EF530	EF530		TF530L	A/D	TF530L	FX530	A/D	FX530	NF530	NF530	T530	T530	
9000		85	93	EF500	EF500		TF500L	A/D	TF500L	FX500	A/D	FX500	NF500	NF500	T500	T500	
		93	98	EF530	EF530		TF530L	A/D	TF530L	FX530	A/D	FX530	NF530	NF530	T530	T530	
		84	93	EF500	EF500	EF500	TF500L	A/D	TF500L	FX500	A/D	FX500	NF500	NF500	T500	T500	T500
		93	98	EF530	EF530	EF500	TF530L	A/D	TF530L	FX530	A/D	FX530	NF530	NF530	T530	T530	T500

SEAT

124		68	80	EF330	EF330										T330	T330	
		70	76	EF330	EF330										T330	T330	
127		72	82	EF330	EF330										T330	T330	
131		78	86	EF380	EF380		TF350L	A/D	TF350L	FX350	A/D	FX350	NF350	NF350	T380	T380	
132		73	82	EF380	EF380		TF350L	A/D	TF350L	FX350	A/D	FX350	NF350	NF350	T380	T380	



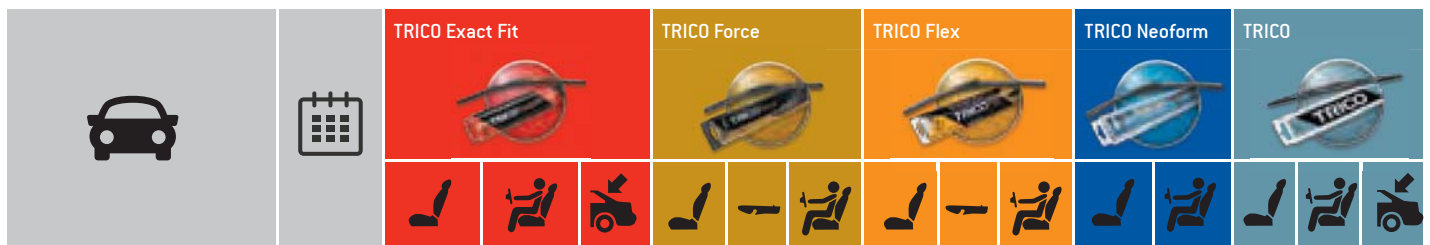

...SEAT

133		74	79	EF380	EF380		TF350L	A/D	TF350L	FX350	A/D	FX350	NF350	NF350	T380	T380	
600 D		63	70	EF280	EF280										T280	T280	
850		66	75	EF330	EF330										T330	T330	
ALHAMBRA		96	00	EF701	EF701	EF400											T400
		01	10	EFB706	EFB706	EF400	TF700L	BC	TF700R	FX700	BC+E	FX700	NF706	NF706			T400
		10		EFB7017L	EFB4017L	EX356	TF700L	BC	TF400L	FX700	BC	FX400	NF7013	NF4013			
ALTEA		04	08	EFB6515	EFB6515	EX330							NF6515	NF6515			
		09		EFB6515	EFB6515	EX333							NF6515	NF6515			
AROSA		97	04	EF480	EF480	EF280	TF480L	A/D	TF480L	FX480	A/D	FX480	NF480	NF480	T480	T480	T280
CORDOBA		93	03	EF530	EF480		TF530L	A/D	TF480L	FX530	A/D	FX480	NF530	NF480	T530	T480	
		95	03	EF530	EF480	EF330	TF530L	A/D	TF480L	FX530	A/D	FX480	NF530	NF480	T530	T480	T330
		96	03	EF530	EF480		TF530L	A/D	TF480L	FX530	A/D	FX480	NF530	NF480	T530	T480	
EXEO		08		EFB555	EFB555								NF555	NF555			
		09		EFB555	EFB555	EX333							NF555	NF555			
FURA		82	86	EF380	EF380		TF350L	A/D	TF350L	FX350	A/D	FX350	NF350	NF350	T380	T380	
IBIZA		84	93	EF450		EF450	TF450L	A/D		FX450	A/D		NF450		T450		T450
		93	02	EF530	EF480	EF330	TF530L	A/D	TF480L	FX530	A/D	FX480	NF530	NF480	T530	T480	T330
		02	06	EF530	EF480	EX330	TF530L	A/D	TF480L	FX530	A/D	FX480	NF530	NF480	T530	T480	T330
		06	09	EFB5318L	EFB4818L	EX330	TF530L	BC	TF480L	FX530	BC	FX480	NF539	NF489			T330
		10	11	EFB6018L	EFB4018L	EX330	TF600L	BC	TF400L	FX600	BC	FX400	NF609	NF409			T330
		12		EFB6018L	EFB4018L	EX333	TF600L	BC	TF400L	FX600	BC	FX400	NF609	NF409			
		10	11	EFB6018L	EFB4018L	EX330	TF600L	BC	TF400L	FX600	BC	FX400	NF609	NF409			
		12		EFB6018L	EFB4018L	EX333	TF600L	BC	TF400L	FX600	BC	FX400	NF609	NF409			
		08	10	EFB5318L	EFB4818L	EX330	TF530L	BC	TF480L	FX530	BC	FX480	NF539	NF489			
		10	11	EFB6018L	EFB4018L	EX330	TF600L	BC	TF400L	FX600	BC	FX400	NF609	NF409			
		12		EFB6018L	EFB4018L	EX333	TF600L	BC	TF400L	FX600	BC	FX400	NF609	NF409			
INCA		95	03	EF530	EF450		TF530L	A/D	TF450L	FX530	A/D	FX450	NF530	NF450	T530	T450	
LEON		99	06	EF530	EF480	EF400	TF530L	A/D	TF480L	FX530	A/D	FX480	NF530	NF480	T530	T480	T400
		05	11			EF400				FX650	BC	FX650					T400
		12		EFB6517L	EFB4017L	EX334	TF650L	BC	TF400L	FX650	BC	FX400	NF6513	NF4013			
MALAGA		84	93	EF450	EF450		TF450L	A/D	TF450L	FX450	A/D	FX450	NF450	NF450	T450	T450	
MARBELLA		86	98	EF400		EF330	TF400L	A/D		FX400	A/D		NF400		T400		T330
Mii		11		EFB6017L	EFB4017L	EX250	TF600L	BC	TF400L	FX600	BC	FX400	NF6013	NF4013			
PANDA		80	86	EF400		EF330	TF400L	A/D		FX400	A/D		NF400		T400		T330
RITMO		78	83	EF400	EF400		TF400L	A/D	TF400L	FX400	A/D	FX400	NF400	NF400	T400	T400	
RONDA		82	88	EF400	EF400	EF380	TF400L	A/D	TF400L	FX400	A/D	FX400	NF400	NF400	T400	T400	T380
TERRA		87	96	EF400	EF400		TF400L	A/D	TF400L	FX400	A/D	FX400	NF400	NF400	T400	T400	
TERRA Van		87	95	EF400	EF400		TF400L	A/D	TF400L	FX400	A/D	FX400	NF400	NF400	T400	T400	
TOLEDO		99	06	EF530	EF480		TF530L	A/D	TF480L	FX530	A/D	FX480	NF530	NF480	T530	T480	
		91	99	EF500	EF500		TF500L	A/D	TF500L	FX500	A/D	FX500	NF500	NF500	T500	T500	
		12		EFB6517L	EFB4017L	EX405	TF650L	BC	TF400L	FX650	BC	FX400	NF6513	NF4013			
	MPV	04	09	EFB6515	EFB6515								NF6515	NF6515			

SKODA

105		76	90	EF400	EF400		TF400L	A/D	TF400L	FX400	A/D	FX400	NF400	NF400	T400	T400	
110		69	82	EF400	EF400		TF400L	A/D	TF400L	FX400	A/D	FX400	NF400	NF400	T400	T400	
		70	82	EF400	EF400		TF400L	A/D	TF400L	FX400	A/D	FX400	NF400	NF400	T400	T400	





...SKODA

130	85	91	EF400	EF400		TF400L	A/D	TF400L	FX400	A/D	FX400	NF400	NF400	T400	T400	
CITIGO	11		EFB6017L	EFB4017L	EX250	TF600L	BC	TF400L	FX600	BC	FX400	NF6013	NF4013			
FABIA	99	07	EF530	EF480		TF530L	A/D	TF480L	FX530	A/D	FX480	NF530	NF480	T530	T480	
	99	08	EF530	EF480		TF530L	A/D	TF480L	FX530	A/D	FX480	NF530	NF480	T530	T480	
	06	13	EFB5318L	EFB5318L	EX333	TF530L	BC	TF530L	FX530	BC	FX530	NF539	NF539			
	13	14	EFB5318L	EFB5318L	EX334	TF530L	BC	TF530L	FX530	BC	FX530	NF539	NF539			
	15		EFB6017L	EFB4017L	EX356	TF600L	BC	TF400L	FX600	BC	FX400	NF6013	NF4013			
	00	07	EF530	EF480		TF530L	A/D	TF480L	FX530	A/D	FX480	NF530	NF480	T530	T480	
	07	13	EFB5318L	EFB5318L	EX400	TF530L	BC	TF530L	FX530	BC	FX530	NF539	NF539			
	13	14	EFB5318L	EFB5318L	EX405	TF530L	BC	TF530L	FX530	BC	FX530	NF539	NF539			
	15		EFB6017L	EFB4017L	EX356	TF600L	BC	TF400L	FX600	BC	FX400	NF6013	NF4013			
FABIA Van	01	07	EF530	EF480		TF530L	A/D	TF480L	FX530	A/D	FX480	NF530	NF480	T530	T480	
FAVORIT	89	94	EF450	EF450	EF400	TF450L	A/D	TF450L	FX450	A/D	FX450	NF450	NF450	T450	T450	T400
	91	95	EF450	EF450	EF400	TF450L	A/D	TF450L	FX450	A/D	FX450	NF450	NF450	T450	T450	T400
FAVORIT Van	92	97	EF450	EF450		TF450L	A/D	TF450L	FX450	A/D	FX450	NF450	NF450	T450	T450	
FELICIA	94	98	EF500	EF500	EF400	TF500L	A/D	TF500L	FX500	A/D	FX500	NF500	NF500	T500	T500	T400
	95	01	EF500	EF500	EF400	TF500L	A/D	TF500L	FX500	A/D	FX500	NF500	NF500	T500	T500	T400
FELICIA Van	95	02	EF500	EF500		TF500L	A/D	TF500L	FX500	A/D	FX500	NF500	NF500	T500	T500	
OCTAVIA	13		EFB6017L	EFB4517L		TF600L	BC	TF450L	FX600	BC	FX450	NF6013	NF4513			
	96	04	EF530	EF480	EF350	TF530L	A/D	TF480L	FX530	A/D	FX480	NF530	NF480	T530	T480	T350
	04	12	EFB606	EFB486	EX400	TF600L	A/D	TF480L	FX600	BC+E	FX480	NF606	NF486			
	98	04	EF530	EF480	EF400	TF530L	A/D	TF480L	FX530	A/D	FX480	NF530	NF480	T530	T480	T400
	04	12	EFB606	EFB486	EX400	TF600L	A/D	TF480L	FX600	BC+E	FX480	NF606	NF486			
	13		EFB6017L	EFB4517L	EX356	TF600L	BC	TF450L	FX600	BC	FX450	NF6013	NF4513			
PRAKTIK	07		EFB5318L	EFB5318L		TF530L	BC	TF530L	FX530	BC	FX530	NF539	NF539			
RAPID	12		EFB6017L	EFB4017L	EX405	TF600L	BC	TF400L	FX600	BC	FX400	NF6013	NF4013			
	83	91	EF400	EF400		TF400L	A/D	TF400L	FX400	A/D	FX400	NF400	NF400	T400	T400	
ROOMSTER	06	13	EFB5318L	EFB5318L	EX333	TF530L	BC	TF530L	FX530	BC	FX530	NF539	NF539			
	14		EFB5318L	EFB5318L	EX334	TF530L	BC	TF530L	FX530	BC	FX530	NF539	NF539			
ROOMSTER Praktik	07		EFB5318L	EFB5318L		TF530L	BC	TF530L	FX530	BC	FX530	NF539	NF539			
SUPERB	02	05	EFB536	EFB506		TF530L	BC	TF500L	FX530	BC+E	FX500	NF536	NF506			
	05	08	EF530	EF530		TF530L	A/D	TF500L	FX530	A/D	FX500	NF530	NF500	T530	T530	
	15		EFB6517L	EFB4517L		TF650L	BC	TF450L	FX650	BC	FX450	NF650	NF450			
	08		EFB6018L	EFB4518L		TF600L	BC	TF450L	FX600	BC	FX450	NF609	NF459			
	09		EFB6018L	EFB4518L	EX405	TF600L	BC	TF450L	FX600	BC	FX450	NF609	NF459			
YETI	09		EFB6018L	EFB4818L	EX284	TF600L	BC	TF480L	FX600	BC	FX480	NF609	NF489			

SMART

CABRIO	00	04	EF530	EF530		TF530L	A/D	TF530R	FX530	A/D	FX530	NF530	NF530	T530	T530	
CITY-COUPE	98	04	EF530	EF530		TF530L	A/D	TF530R	FX530	A/D	FX530	NF530	NF530	T530	T530	
CROSSBLADE	02	03	EF530	EF530		TF530L	A/D	TF530R	FX530	A/D	FX530	NF530	NF530	T530	T530	
FORFOUR	04	06	EF600	EF450	EX357	TF600L	A/D	TF450L	FX600	A/D	FX450	NF600	NF450	T600	T450	
	15		EFB5014L	EFB3514L	EX230	TF500L	F	TF350L	FX500	E1	FX350					
FORTWO	04	06	EF530	EF530		TF530L	A/D	TF530R	FX530	A/D	FX530	NF530	NF530	T530	T530	
	07	13	EFB5517L	EFB5317R	EX251	TF550L	BC	TF530R	FX550	BC	FX530	NF557	NF537			
	14		EFB5014L	EFB3514L		TF500L	F	TF350L	FX500	E1	FX350					
	04	06	EF530	EF530		TF530L	A/D	TF530R	FX530	A/D	FX530	NF530	NF530	T530	T530	





...SMART

...FORTWO		04	06	EF530	EF530		TF530R	A/D	TF530L	FX530	A/D	FX530	NF530	NF530	T530	T530	
		07	13	EFB5517L	EFB5317R		TF550L	BC	TF530R	FX550	BC	FX530	NF557	NF537			
		14		EFB5014L	EFB3514L		TF500L	F	TF350L	FX500	E1	FX350					
ROADSTER		03	05	EF500	EF450		TF500L	A/D	TF450L	FX500	A/D	FX450	NF500	NF450	T500	T450	
		03	05	EF500	EF450		TF500L	A/D	TF450L	FX500	A/D	FX450	NF500	NF450	T500	T450	

SSANGYONG

ACTYON		05	12	EF550	EF480	EF500	TF550L	A/D	TF480L	FX550	A/D	FX480	NF550	NF480	T550	T480	T500
KORANDO		88	11	EF450	EF450	EF280	TF450L	A/D	TF450L	FX450	A/D	FX450	NF450	NF450	T450	T450	T280
		12		HF600	HF400		TF600L	A/D	TF400L	FX600	A/D	FX400	NF600	NF400			
KYRON		05		EF550	EF480	EX305	TF550L	A/D	TF480L	FX550	A/D	FX480	NF550	NF480	T550	T480	
MUSSO		95		EF500	EF450	EF350	TF500L	A/D	TF450L	FX500	A/D	FX450	NF500	NF450	T500	T450	T350
MUSSO SPORTS		04		EF500	EF450		TF500L	A/D	TF450L	FX500	A/D	FX450	NF500	NF450	T500	T450	
REXTON		02	12	EF500	EF500	EF350	TF500L	A/D	TF500L	FX500	A/D	FX500	NF500	NF500	T500	T500	T350
		13		HF500	HF500	EF350	TF500L	A/D	TF500L	FX500	A/D	FX500	NF500	NF500			
RODIUS		05	13	EF600	EF450	EF280	TF600L	A/D	TF450L	FX600	A/D	FX450	NF600	NF450	T600	T450	T280
		13		HF600	HF450	EX310	TF600L	A/D	TF450L	FX600	A/D	FX450	NF600	NF450			
TIVOLI		15		EF600	EF400		TF600L	A/D	TF400L	FX600	A/D	FX400	NF600	NF400	T600	T400	

SUBARU

BRZ		12		HF550	HF500		TF550L	A/D	TF500L	FX550	A/D	FX500	NF550	NF500			
FORESTER		97	07	EF530	EF480	EF380	TF530L	A/D	TF480L	FX530	A/D	FX480	NF530	NF480	T530	T480	T380
		08	13	HF600	HF400	EX351	TF600L	A/D	TF400L	FX600	A/D	FX400	NF600	NF400			
		13		HF650	HF430	EX351	TF650L	A/D	TF430L	FX650	A/D	FX430	NF650	NF430			
IMPREZA		92	00	EF530	EF450		TF530L	A/D	TF450L	FX530	A/D	FX450	NF530	NF450	T530	T450	
		00	07	EF550	EF430	EF380	TF550L	A/D	TF430L	FX550	A/D	FX430	NF550	NF430	T550	T430	T380
		08		HF600	HF400		TF600L	A/D	TF400L	FX600	A/D	FX400	NF600	NF400			
		02	07	EF550	EF430	EX351	TF550L	A/D	TF430L	FX550	A/D	FX430	NF550	NF430	T550	T430	
		08		HF600	HF400	EX351	TF600L	A/D	TF400L	FX600	A/D	FX400	NF600	NF400			
		92	00	EF530	EF450	EF400	TF530L	A/D	TF450L	FX530	A/D	FX450	NF530	NF450	T530	T450	T400
		00	07	EF550	EF430	EF380	TF550L	A/D	TF430L	FX550	A/D	FX430	NF550	NF430	T550	T430	T380
		93	00	EF530	EF450		TF530L	A/D	TF450L	FX530	A/D	FX450	NF530	NF450	T530	T450	
JUSTY		84	95	EF450	EF430	EF400	TF450L	A/D	TF430L	FX450	A/D	FX430	NF450	NF430	T450	T430	T400
		95	03	EF530	EF450	EF380	TF530L	A/D	TF450L	FX530	A/D	FX450	NF530	NF450	T530	T450	T380
		03	07	EF480	EF450	EF330	TF480L	A/D	TF450L	FX480	A/D	FX450	NF480	NF450	T480	T450	T330
		08		EF500	EF450	EX350	TF500L	A/D	TF450L	FX500	A/D	FX450	NF500	NF450	T500	T450	
LEGACY		89	94	EF500	EF450		TF500L	A/D	TF450L	FX500	A/D	FX450	NF500	NF450	T500	T450	
		94	98	EF530	EF480		TF530L	A/D	TF480L	FX530	A/D	FX480	NF530	NF480	T530	T480	
		98	03	EF550	EF550		TF550L	A/D	TF550L	FX550	A/D	FX550	NF550	NF550	T550	T550	
		03	08	EF600	EF450		TF600L	A/D	TF450L	FX600	A/D	FX450	NF600	NF450	T600	T450	
		09		HF600	HF450		TF600L	A/D	TF450L	FX600	A/D	FX450	NF600	NF450			
		89	94	EF500	EF450		TF500L	A/D	TF450L	FX500	A/D	FX450	NF500	NF450	T500	T450	
		94	98	EF530	EF480	EF380	TF530L	A/D	TF480L	FX530	A/D	FX480	NF530	NF480	T530	T480	T380
		98	03	EF550	EF550		TF550L	A/D	TF550L	FX550	A/D	FX550	NF550	NF550	T550	T550	
		03	08	EF600	EF450	EX351	TF600L	A/D	TF450L	FX600	A/D	FX450	NF600	NF450	T600	T450	
		09		HF600	HF450	EX351	TF600L	A/D	TF450L	FX600	A/D	FX450	NF600	NF450			
LEONE		84	94	EF450*	EF450*										T450*	T450*	
		84	94	EF450*	EF450*	EF400									T450*	T450*	T400



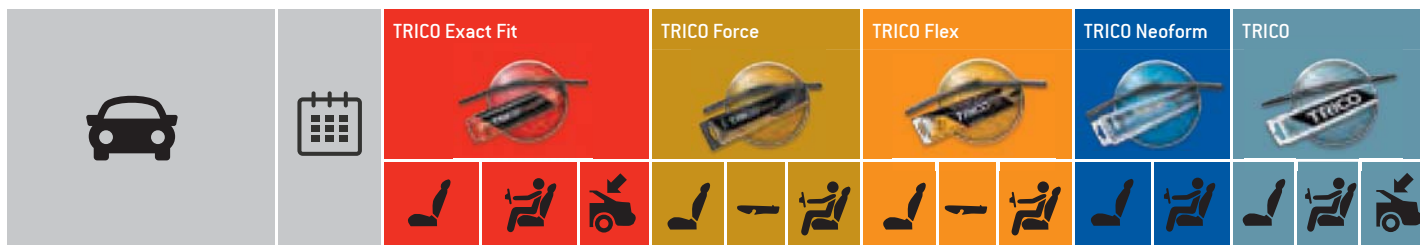

...SUBARU

LIBERO	83	00	EF380	EF380		TF350L	A/D	TF350L	FX350	A/D	FX350	NF350	NF350	T380	T380	
OUTBACK	00	03	EF600	EF450		TF600L	A/D	TF450L	FX600	A/D	FX450	NF600	NF450	T600	T450	
	03	08	EF600	EF450	EX351	TF600L	A/D	TF450L	FX600	A/D	FX450	NF600	NF450	T600	T450	
	09	14	HF600	HF450	EX351	TF600L	A/D	TF450L	FX600	A/D	FX450	NF600	NF450			
	15		HF650	HF430	EX351	TF650L	A/D	TF430L	FX650	A/D	FX430	NF650	NF430			
REX	81	92	EF400	EF400		TF400L	A/D	TF400L	FX400	A/D	FX400	NF400	NF400	T400	T400	
SVX	92	97	EF550	EF500		TF550L	A/D	TF500L	FX550	A/D	FX500	NF550	NF500	T550	T500	
TRIBECA	05		TX650	EF500	EX351											
VIVIO	92	98	EF480	EF380		TF480L	A/D	TF350L	FX480	A/D	FX350	NF480	NF350	T480	T380	
WRX STI	14		HF650	HF400	EX305	TF650L	A/D	TF400L	FX650	A/D	FX400	NF650	NF400			
XV	12		HF650	HF400	EX351	TF650L	A/D	TF400L	FX650	A/D	FX400	NF650	NF400			

SUZUKI

ALTO	82	85	EF350	EF350		TF350L	A/D	TF350L	FX350	A/D	FX350	NF350	NF350	T350	T350	
	85	93	EF430*	EF430*										T430*	T430*	
	94	07	EF450	EF400	EF330	TF450L	A/D	TF400L	FX450	A/D	FX400	NF450	NF400	T450	T400	T330
	09		EF530	EF350		TF530L	A/D	TF350L	FX530	A/D	FX350	NF530	NF350	T530	T350	
BALENO	95	02	EF500	EF450		TF500L	A/D	TF450L	FX500	A/D	FX450	NF500	NF450	T500	T450	
	95	02	EF500	EF450	EF380	TF500L	A/D	TF450L	FX500	A/D	FX450	NF500	NF450	T500	T450	T380
	96	02	EF500	EF450	EF350	TF500L	A/D	TF450L	FX500	A/D	FX450	NF500	NF450	T500	T450	T350
CAPPUCINO	92	98	EF450	EF450		TF450L	A/D	TF450L	FX450	A/D	FX450	NF450	NF450	T450	T450	
CARRY	80	85	EF280	EF280										T280	T280	
	99		EF380	EF380		TF350L	A/D	TF350L	FX350	A/D	FX350	NF350	NF350	T380	T380	
GRAND VITARA	98	04	EF480	EF480	EF380	TF480L	A/D	TF480L	FX480	A/D	FX480	NF480	NF480	T480	T480	T380
	05		EF480	EF480	EX305	TF480L	A/D	TF480L	FX480	A/D	FX480	NF480	NF480	T480	T480	
IGNIS	00	08	EF480	EF450	EF350	TF480L	A/D	TF450L	FX480	A/D	FX450	NF480	NF450	T480	T450	T350
JIMNY	98		EF450	EF400	EF280	TF450L	A/D	TF400L	FX450	A/D	FX400	NF450	NF400	T450	T400	T280
KIZASHI	10		HF600	HF500		TF600L	A/D	TF500L	FX600	A/D	FX500	NF600	NF500			
LIANA	01	07	EF550	EF450		TF550L	A/D	TF450L	FX550	A/D	FX450	NF550	NF450	T550	T450	
	01	07	EF550	EF450		TF550L	A/D	TF450L	FX550	A/D	FX450	NF550	NF450	T550	T450	
LJ 80	80	84	EF280	EF280										T280	T280	
SAMURAI	88	04	EF280	EF280										T280	T280	
SJ 410	81	88	EF280	EF280										T280	T280	
SJ 413	84	90	EF280	EF280										T280	T280	
SPLASH	08		EF550	EF400	EX252	TF550L	A/D	TF400L	FX550	A/D	FX400	NF550	NF400	T550	T400	
SUPER CARRY	85	99	EF380	EF380		TF350L	A/D	TF350L	FX350	A/D	FX350	NF350	NF350	T380	T380	
SWIFT	89	01	EF530	EF450		TF530L	A/D	TF450L	FX530	A/D	FX450	NF530	NF450	T530	T450	
	83	89	EF430*	EF430*	EF380									T430*	T430*	T380
	89	03	EF530	EF450	EF380	TF530L	A/D	TF450L	FX530	A/D	FX450	NF530	NF450	T530	T450	T380
	05		EF550	EF430	EX252	TF550L	A/D	TF430L	FX550	A/D	FX430	NF550	NF430	T550	T430	
	91	96	EF530	EF450		TF530L	A/D	TF450L	FX530	A/D	FX450	NF530	NF450	T530	T450	
SX4	06		EF650	EF350	EX252	TF650L	A/D	TF350L	FX650	A/D	FX350	NF650	NF350	T650	T350	
	06		EF650	EF350	EX252	TF650L	A/D	TF350L	FX650	A/D	FX350	NF650	NF350	T650	T350	
SX4 S-Cross	13		HF650	HF350	EX252	TF650L	A/D	TF350L	FX650	A/D	FX350	NF650	NF350			
VITARA	88	98	EF430*	EF430*	EF380									T430*	T430*	T380
	88	02	EF430*	EF430*										T430*	T430*	
WAGON R	92	97	EF500	EF450	EF280	TF500L	A/D	TF450L	FX500	A/D	FX450	NF500	NF450	T500	T450	T280





...SUZUKI

...WAGON R	98	07	EF500	EF450	EF280	TF500L	A/D	TF450L	FX500	A/D	FX450	NF500	NF450	T500	T450	T280
X-90	95	97	EF430	EF450		TF430L	A/D	TF450L	FX430	A/D	FX450	NF430	NF450	T430	T450	

TALBOT

AVENGER	72	81	EF400	EF400	EF280	TF400L	A/D	TF400L	FX400	A/D	FX400	NF400	NF400	T400	T400	T280
Special Design	70	81	EF400	EF400		TF400L	A/D	TF400L	FX400	A/D	FX400	NF400	NF400	T400	T400	
HORIZON	78	86	EF400	EF400		TF400L	A/D	TF400L	FX400	A/D	FX400	NF400	NF400	T400	T400	
MATRA BAGHEERA	74	80	EF400	EF400	EF450	TF400L	A/D	TF400L	FX400	A/D	FX400	NF400	NF400	T400	T400	T450
MURENA	80	85	EF500	EF500		TF500L	A/D	TF500L	FX500	A/D	FX500	NF500	NF500	T500	T500	
SAMBA	81	86	EF400	EF400	EF350	TF400L	A/D	TF400L	FX400	A/D	FX400	NF400	NF400	T400	T400	T350
	81	86	EF400	EF400		TF400L	A/D	TF400L	FX400	A/D	FX400	NF400	NF400	T400	T400	
SIMCA 1000	61	78	EF280	EF280										T280	T280	
SIMCA 1100	68	80	EF280	EF280										T280	T280	
	68	80	EF280	EF280										T280	T280	
SIMCA 1200 S	68	72	EF280	EF280										T280	T280	
SIMCA 1300	63	68	EF280	EF280										T280	T280	
SIMCA 1301	66	76	EF280	EF280										T280	T280	
	66	72	EF280	EF280										T280	T280	
SIMCA 1500	64	68	EF280	EF280										T280	T280	
SIMCA 1501	66	76	EF280	EF280										T280	T280	
	66	76	EF280	EF280										T280	T280	
SIMCA 1609/1610	76	80	EF280	EF280										T280	T280	
SIMCA SIM'4	68	72	EF280	EF280										T280	T280	
SIMCA SUNBEAM	77	83	EF400	EF400	EF430*	TF400L	A/D	TF400L	FX400	A/D	FX400	NF400	NF400	T400	T400	T430*
SOLARA	80	86	EF400	EF400		TF400L	A/D	TF400L	FX400	A/D	FX400	NF400	NF400	T400	T400	
TAGORA	80	87	EF450	EF450		TF450L	A/D	TF450L	FX450	A/D	FX450	NF450	NF450	T450	T450	

TATA (TELCO)

INDICA	98		EF550	EF550	EF280	TF550L	A/D	TF550L	FX550	A/D	FX550	NF550	NF550	T550	T550	T280
INDIGO	03	04	EF600	EF430	EF280	TF600L	A/D	TF430L	FX600	A/D	FX430	NF600	NF430	T600	T430	T280
	05		EF550	EF550		TF550L	A/D	TF550L	FX550	A/D	FX550	NF550	NF550	T550	T550	
	03	04	EF600	EF430	EF280	TF600L	A/D	TF430L	FX600	A/D	FX430	NF600	NF430	T600	T430	T280
	05		EF550	EF430	EF280	TF550L	A/D	TF430L	FX550	A/D	FX430	NF550	NF430	T550	T430	T280
SAFARI	98		EF600	EF500	EF330	TF600L	A/D	TF500L	FX600	A/D	FX500	NF600	NF500	T600	T500	T330
SIERRA	95	00	EF480*	EF480*										T480*	T480*	

TOYOTA

4 RUNNER	84	89	EF450*	EF450*	EF450*									T450*	T450*	T450*
	87	02	EF430	EF430		TF430L	A/D	TF430L	FX430	A/D	FX430	NF430	NF430	T430	T430	
AURIS	06	11	HF650	HF400	EX305	TF600L	A/D	TF400L	FX600	A/D	FX400	NF650	NF400			
	12		HF650	HF350		TF650L	A/D	TF350L	FX650	A/D	FX350	NF650	NF350			
AVENSIS	97	03	EF530	EF450		TF530L	A/D	TF450L	FX530	A/D	FX450	NF530	NF450	T530	T450	
	03	08	EF600	EF400		TF600L	A/D	TF400L	FX600	A/D	FX400	NF600	NF400	T600	T400	
	97	03	EF530	EF450	EF500	TF530L	A/D	TF450L	FX530	A/D	FX450	NF530	NF450	T530	T450	T500
	03	05	EF600	EF400	EF400	TF600L	A/D	TF400L	FX600	A/D	FX400	NF600	NF400	T600	T400	T400
	06	08	EF600	EF400	EX350	TF600L	A/D	TF400L	FX600	A/D	FX400	NF600	NF400	T600	T400	
	97	03	EF530	EF450	EF330	TF530L	A/D	TF450L	FX530	A/D	FX450	NF530	NF450	T530	T450	T330
	03	08	EF600	EF400	EX305	TF600L	A/D	TF400L	FX600	A/D	FX400	NF600	NF400	T600	T400	
AVENSIS VERSO	01	09	EF600	EF400	EX280	TF600L	A/D	TF400L	FX600	A/D	FX400	NF600	NF400	T600	T400	



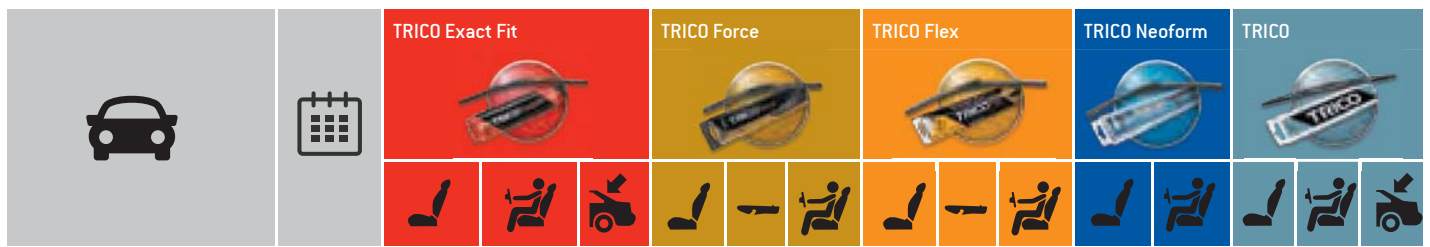

...TOYOTA

AYGO	05	14	EF650		EX301	TF650L	A/D		FX650	A/D		NF650		T650		
	14		EFB6517L		EX305	TF650L	BC		FX650	BC		NF657				
CAMI	99	00	EF500	EF350		TF500L	A/D	TF350L	FX500	A/D	FX350	NF500	NF350	T500	T350	
CAMRY	86	91	EF500*	EF450*	EF400*									T500*	T450*	T400*
	91	01	EF530	EF480		TF530L	A/D	TF480L	FX530	A/D	FX480	NF530	NF480	T530	T480	
	01	06	EF600	EF480		TF600L	A/D	TF480L	FX600	A/D	FX480	NF600	NF480	T600	T480	
	06	11	EF600	EF500		TF600L	A/D	TF500L	FX600	A/D	FX500	NF600	NF500	T600	T500	
	83	88	EF530	EF480		TF530L	A/D	TF480L	FX530	A/D	FX480	NF530	NF480	T530	T480	
	86	91	EF500*	EF450*	EF400*									T500*	T450*	T400*
	91	96	EF530	EF480	EF280	TF530L	A/D	TF480L	FX530	A/D	FX480	NF530	NF480	T530	T480	T280
	96	02	EF530	EF480		TF530L	A/D	TF480L	FX530	A/D	FX480	NF530	NF480	T530	T480	
CARIBE	86	94	EF280	EF280										T280	T280	
CARINA	73	78	EF380	EF380		TF350L	A/D	TF350L	FX350	A/D	FX350	NF350	NF350	T380	T380	
	78	88	EF430*	EF430*										T430*	T430*	
	87	93	EF500*	EF450*										T500*	T450*	
	92	97	EF530	EF450		TF530L	A/D	TF450L	FX530	A/D	FX450	NF530	NF450	T530	T450	
	83	88	EF430*	EF430*										T430*	T430*	
	87	93	EF500*	EF450*										T500*	T450*	
	92	97	EF530	EF450	EF500	TF530L	A/D	TF450L	FX530	A/D	FX450	NF530	NF450	T530	T450	T500
	78	83	EF430*	EF430*	EF400*									T430*	T430*	T400*
	87	92	EF500*	EF450*										T500*	T450*	
	92	97	EF530	EF450	EF400	TF530L	A/D	TF450L	FX530	A/D	FX450	NF530	NF450	T530	T450	T400
CELICA	71	78	EF380	EF380		TF350L	A/D	TF350L	FX350	A/D	FX350	NF350	NF350	T380	T380	
	86	89	EF450*	EF450*										T450*	T450*	
	77	85	EF430*	EF430*	EF400*									T430*	T430*	T400*
	85	89	EF450*	EF450*										T450*	T450*	
	77	81	EF430*	EF430*	EF400*									T430*	T430*	T400*
	81	85	EF430*	EF430*										T430*	T430*	
	87	93	EF500	EF450		TF500L	A/D	TF450L	FX500	A/D	FX450	NF500	NF450	T500	T450	
	93	99	EF530	EF480	EF500	TF530L	A/D	TF480L	FX530	A/D	FX480	NF530	NF480	T530	T480	T500
	99	05	EF650	EF400	EF500	TF650L	A/D	TF400L	FX650	A/D	FX400	NF650	NF400	T650	T400	T500
	85	89	EF450*	EF450*										T450*	T450*	
	89	93	EF500	EF450		TF500L	A/D	TF450L	FX500	A/D	FX450	NF500	NF450	T500	T450	
	93	99	EF530	EF480		TF530L	A/D	TF480L	FX530	A/D	FX480	NF530	NF480	T530	T480	
CELICA SUPRA	81	85	EF450*	EF450*										T450*	T450*	
COROLLA	72	81	EF380	EF380		TF350L	A/D	TF350L	FX350	A/D	FX350	NF350	NF350	T380	T380	
	79	83	EF500	EF450		TF500L	A/D	TF450L	FX500	A/D	FX450	NF500	NF450	T500	T450	
	83	89	EF450*	EF430*										T450*	T430*	
	87	93	EF500*	EF450*										T500*	T450*	
	91	01	EF500	EF450		TF500L	A/D	TF450L	FX500	A/D	FX450	NF500	NF450	T500	T450	
	01	05	EF550	EF450		TF550L	A/D	TF450L	FX550	A/D	FX450	NF550	NF450	T550	T450	
	14		HF650	HF350		TF650L	A/D	TF350L	FX650	A/D	FX350	NF650	NF350			
	76	80	EF380	EF380		TF350L	A/D	TF350L	FX350	A/D	FX350	NF350	NF350	T380	T380	
	79	83	EF430*	EF430*	EF400									T430*	T430*	T400
	83	89	EF450*	EF430*	EF430*									T450*	T430*	T430*
	92	97	EF500	EF450	EF450	TF500L	A/D	TF450L	FX500	A/D	FX450	NF500	NF450	T500	T450	T450

TRICO Exact Fit TRICO Force TRICO Flex TRICO Neoform TRICO

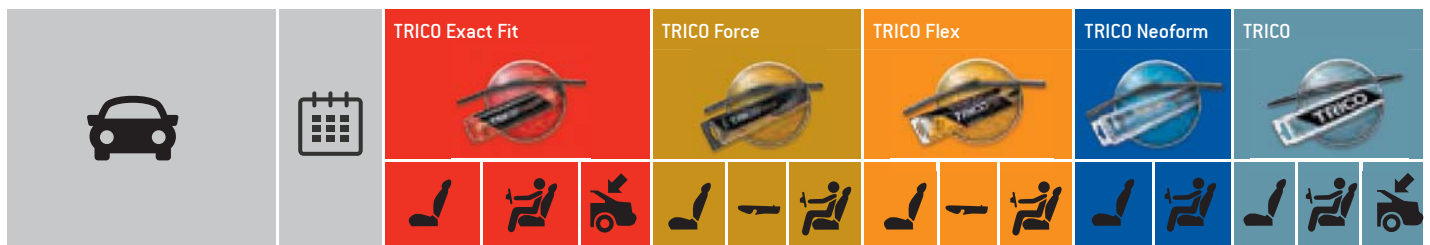

...TOYOTA																	
...COROLLA		97	02	EF500	EF450	EF400	TF500L	A/D	TF450L	FX500	A/D	FX450	NF500	NF450	T500	T450	T400
		02	07	EF550	EF450	EF350	TF550L	A/D	TF450L	FX550	A/D	FX450	NF550	NF450	T550	T450	T350
		75	87	EF430*	EF430*	EF400*									T430*	T430*	T400*
		87	92	EF500*	EF450*	EF400									T500*	T450*	T400
		92	97	EF500	EF450	EF400	TF500L	A/D	TF450L	FX500	A/D	FX450	NF500	NF450	T500	T450	T400
		97	01	EF500	EF450	EF350	TF500L	A/D	TF450L	FX500	A/D	FX450	NF500	NF450	T500	T450	T350
		02	07	EF550	EF450	EX350	TF550L	A/D	TF450L	FX550	A/D	FX450	NF550	NF450	T550	T450	
		75	81	EF380	EF380		TF350L	A/D	TF350L	FX350	A/D	FX350	NF350	NF350	T380	T380	
		83	87	EF450*	EF450*										T450*	T450*	
COROLLA VERSO		02	04	EF650	EF400		TF650L	A/D	TF400L	FX650	A/D	FX400	NF650	NF400	T650	T400	
		04	09	EF650	EF400	EX280	TF650L	A/D	TF400L	FX650	A/D	FX400	NF650	NF400	T650	T400	
CORONA		79	81	EF430*	EF430*	EF430*									T430*	T430*	T430*
CRESSIDA		77	93	EF450*	EF450*										T450*	T450*	
		77	85	EF430*	EF430*	EF350									T430*	T430*	T350
CROWN		80	85	EF450*	EF450*										T450*	T450*	
		80	83	EF430*	EF430*	EF350									T430*	T430*	T350
DYNA		77	87	EF400	EF400		TF400L	A/D	TF400L	FX400	A/D	FX400	NF400	NF400	T400	T400	
		01		EF430	EF430		TF430L	A/D	TF430L	FX430	A/D	FX430	NF430	NF430	T430	T430	
DYNA 100		85	95	EF400	EF400		TF400L	A/D	TF400L	FX400	A/D	FX400	NF400	NF400	T400	T400	
DYNA 150		85	95	EF400	EF400		TF400L	A/D	TF400L	FX400	A/D	FX400	NF400	NF400	T400	T400	
		95	01	EF430	EF430		TF430L	A/D	TF430L	FX430	A/D	FX430	NF430	NF430	T430	T430	
DYNA 200		88	95	EF400	EF400		TF400L	A/D	TF400L	FX400	A/D	FX400	NF400	NF400	T400	T400	
		95	01	EF430	EF430		TF430L	A/D	TF430L	FX430	A/D	FX430	NF430	NF430	T430	T430	
DYNA 250		95	03	EF430	EF430		TF430L	A/D	TF430L	FX430	A/D	FX430	NF430	NF430	T430	T430	
DYNA 300		95	02	EF430	EF430		TF430L	A/D	TF430L	FX430	A/D	FX430	NF430	NF430	T430	T430	
DYNA 400		00		EF430	EF430		TF430L	A/D	TF430L	FX430	A/D	FX430	NF430	NF430	T430	T430	
ECHO		99	05	EF550	EF350		TF550L	A/D	TF350L	FX550	A/D	FX350	NF550	NF350	T550	T350	
		99	05	EF550	EF350		TF550L	A/D	TF350L	FX550	A/D	FX350	NF550	NF350	T550	T350	
GT 86		12		HF550	HF500		TF550L	A/D	TF500L	FX550	A/D	FX500	NF550	NF500			
HIACE		89		EF530	EF530	EF430*	TF530L	A/D	TF530L	FX530	A/D	FX530	NF530	NF530	T530	T530	T430*
HIACE Van		90		EF530	EF530		TF530L	A/D	TF530L	FX530	A/D	FX530	NF530	NF530	T530	T530	
HILUX	SUV	89	04	EF430	EF430	EF430									T430	T430	T430
HILUX Van		72	05	EF430	EF430										T430	T430	
		05		EF530	EF480		TF530L	A/D	TF480L	FX530	A/D	FX480	NF530	NF480	T530	T480	
IQ		09		HF550	HF450	EX280	TF550L	A/D	TF450L	FX550	A/D	FX450	NF550	NF450			
LAND CRUISER	SUV	69	86	EF380	EF380	EF280	TF350L	A/D	TF350L	FX350	A/D	FX350	NF350	NF350	T380	T380	T280
		81	89	EF430*	EF430*	EF350									T430*	T430*	T350
		90	96	EF450	EF450	EF350	TF450L	A/D	TF450L	FX450	A/D	FX450	NF450	NF450	T450	T450	T350
		02	06	EF550	EF530	EX350	TF550L	A/D	TF530L	FX550	A/D	FX530	NF550	NF530	T550	T530	
		07		HF550	HF530	EX350	TF550L	A/D	TF530L	FX550	A/D	FX530	NF550	NF530			
LAND CRUISER 80		90	98	EF400	EF400	EF400	TF400L	A/D	TF400L	FX400	A/D	FX400	NF400	NF400	T400	T400	T400
LAND CRUISER 90		95		EF480	EF480	EF350	TF480L	A/D	TF480L	FX480	A/D	FX480	NF480	NF480	T480	T480	T350
LAND CRUISER 100		98		HF600	HF550	EF350	TF600L	A/D	TF550L	FX600	A/D	FX550	NF600	NF550	T600		T350
LAND CRUISER 150		10		HF650	HF500		TF650L	A/D	TF500L	FX650	A/D	FX500	NF650	NF500			
LAND CRUISER Van		69	86	EF380	EF380		TF350L	A/D	TF350L	FX350	A/D	FX350	NF350	NF350	T380	T380	
		81	86	EF430*	EF430*										T430*	T430*	





...TOYOTA

LITEACE	84	92	EF450*	EF450*	EF400									T450*	T450*	T400		
LITEACE Van	92	97	EF450*	EF450*										T450*	T450*			
MATRIX	01	04	EF530	EF450		TF530L	A/D	TF450L	FX530	A/D	FX450	NF530	NF450	T530	T450			
MR 2	84	88	EF450*	EF450*										T450*	T450*			
			89	00	EF500	EF480		TF500L	A/D	TF480L	FX500	A/D	FX480	NF500	NF480	T500	T480	
PASEO	00	05	EF500	EF480		TF500L	A/D	TF480L	FX500	A/D	FX480	NF500	NF480	T500	T480			
			95	00	EF500	EF450		TF500L	A/D	TF450L	FX500	A/D	FX450	NF500	NF450	T500	T450	
			96	00	EF500	EF450		TF500L	A/D	TF450L	FX500	A/D	FX450	NF500	NF450	T500	T450	
PICNIC	96	03	EF600	EF400	EF400	TF600L	A/D	TF400L	FX600	A/D	FX400	NF600	NF400	T600	T400	T400		
PREVIA	00	06	TX700	EF450	EX402													
PRIUS	00	04	EF650	EF400		TF650L	A/D	TF400L	FX650	A/D	FX400	NF650	NF400	T650	T400			
PRIUS	03	09	EF650	EF400	EF400	TF650L	A/D	TF400L	FX650	A/D	FX400	NF650	NF400	T650	T400	T400		
			09		HF650	HF400	EF400	TF650L	A/D	TF400L	FX650	A/D	FX400	NF650	NF400			T400
PRIUS+	11		HF700	HF350	EX280	TF700L	A/D	TF350L	FX700	A/D	FX350	NF700	NF350					
RAV 4	94	00	EF500	EF450	EF350	TF500L	A/D	TF450L	FX500	A/D	FX450	NF500	NF450	T500	T450	T350		
			00	05	EF600	EF480	EF280	TF600L	A/D	TF480L	FX600	A/D	FX480	NF600	NF480	T600	T480	T280
			05	12	HF600	HF430	EX305	TF600L	A/D	TF430L	FX600	A/D	FX430	NF600	NF430			
			13		HF650	HF400		TF650L	A/D	TF400L	FX650	A/D	FX400	NF650	NF400			
SEQUOIA	00	07	EF480	EF480		TF480L	A/D	TF480L	FX480	A/D	FX480	NF480	NF480	T480	T480			
SIENNA	97	03	EF600	EF450	EF430	TF600L	A/D	TF450L	FX600	A/D	FX450	NF600	NF450	T600	T450	T430		
			03	09	EF650	EF480	EF400	TF650L	A/D	TF480L	FX650	A/D	FX480	NF650	NF480	T650	T480	T400
STARLET	78	84	EF400*	EF400*										T400*	T400*			
			84	89	EF450*	EF400*									T450*	T400*		
			89	96	EF500*	EF450*	EF400									T500*	T450*	T400
			96	99	EF500	EF430	EF400	TF500L	A/D	TF430L	FX500	A/D	FX430	NF500	NF430	T500	T430	T400
	76	78	EF380	EF380		TF350L	A/D	TF350L	FX350	A/D	FX350	NF350	NF350	T380	T380			
			78	84	EF400*	EF400*									T400*	T400*		
SUPRA	93	93	EF500	EF450	EF450	TF500L	A/D	TF450L	FX500	A/D	FX450	NF500	NF450	T500	T450	T450		
			93	02	EF500	EF450	EF450	TF500L	A/D	TF450L	FX500	A/D	FX450	NF500	NF450	T500	T450	T450
TERCEL	79	88	EF380*	EF380*	EF350									T380*	T380*	T350		
			86	94	EF450*	EF450*									T450*	T450*		
URBAN CRUISER	09		HF600	HF350		TF600L	A/D	TF350L	FX600	A/D	FX350	NF600	NF350					
VERSO	09		HF650	HF400	EX305	TF650L	A/D	TF400L	FX650	A/D	FX400	NF650	NF400					
VERSO S	10		HF700		EX305	TF700L	A/D		FX700	A/D		NF700						
YARIS	FR	99	05	EF530	EF350	EX301	TF530L	A/D	TF350L	FX530	A/D	FX350	NF530	NF350	T530	T350		
				J	99	05	EF530	EF350		TF530L	A/D	TF350L	FX530	A/D	FX350	NF530	NF350	T530
	FR	06	11	EF600	EF350	EX308	TF600L	A/D	TF350L	FX600	A/D	FX350	NF600	NF350	T600	T350		
				J	06	11	EF600	EF350	EX305	TF600L	A/D	TF350L	FX600	A/D	FX350	NF600	NF350	T600
	12		HF700		EX305	TF700L	A/D		FX700	A/D		NF700						
YARIS VERSO	99	05	EF550	EF400	EX402	TF550L	A/D	TF400L	FX550	A/D	FX400	NF550	NF400	T550	T400			

TRIUMPH

2.5 PI	68	75	EF350	EF350		TF350L	A/D	TF350L	FX350	A/D	FX350	NF350	NF350	T350	T350	
2.5 PI	68	75	EF350	EF350		TF350L	A/D	TF350L	FX350	A/D	FX350	NF350	NF350	T350	T350	
1300	65	70	EF350	EF350		TF350L	A/D	TF350L	FX350	A/D	FX350	NF350	NF350	T350	T350	
1500	70	77	EF350	EF350		TF350L	A/D	TF350L	FX350	A/D	FX350	NF350	NF350	T350	T350	
2000	68	75	EF350	EF350		TF350L	A/D	TF350L	FX350	A/D	FX350	NF350	NF350	T350	T350	



		TRICO Exact Fit			TRICO Force			TRICO Flex			TRICO Neoform		TRICO		

...TRIUMPH

...2000		68	75	EF350	EF350	EF350	TF350L	A/D	TF350L	FX350	A/D	FX350	NF350	NF350	T350	T350	T350
2500		74	77	EF350	EF350		TF350L	A/D	TF350L	FX350	A/D	FX350	NF350	NF350	T350	T350	
		74	77	EF350	EF350	EF350	TF350L	A/D	TF350L	FX350	A/D	FX350	NF350	NF350	T350	T350	T350
ACCLAIM		82	85	EF400*	EF400*										T400*	T400*	
DOLOMITE		72	81	EF350	EF350		TF350L	A/D	TF350L	FX350	A/D	FX350	NF350	NF350	T350	T350	
GT6		66	73	EF280	EF280										T280	T280	
HERALD		67	71	EF280	EF280										T280	T280	
		61	71	EF280	EF280										T280	T280	
		61	71	EF280	EF280										T280	T280	
SPITFIRE		62	80	EF280	EF280										T280	T280	
TOLEDO		70	77	EF350	EF350		TF350L	A/D	TF350L	FX350	A/D	FX350	NF350	NF350	T350	T350	
TR 4		61	65	EF280	EF280										T280	T280	
TR 4A		65	67	EF280	EF280										T280	T280	
TR 5		67	68	EF280	EF280										T280	T280	
TR 6		69	76	EF280	EF280										T280	T280	
TR 7		76	81	EF400*	EF450*										T400*	T450*	
		79	81	EF400*	EF450*										T400*	T450*	
TR 8		80	81	EF400*	EF450*										T400*	T450*	

TVR

CERBERA		96	03	EF400	EF400		TF400L	A/D	TF400L	FX400	A/D	FX400	NF400	NF400	T400	T400	
CHIMAERA		92	03	EF430	EF430		TF430L	A/D	TF430L	FX430	A/D	FX430	NF430	NF430	T430	T430	
GRIFFITH		90	02	EF400	EF400		TF400L	A/D	TF400L	FX400	A/D	FX400	NF400	NF400	T400	T400	
TUSCAN		98	06	EF530	EF530		TF530L	A/D	TF530L	FX530	A/D	FX530	NF530	NF530	T530	T530	

UAZ

3160		94		EF330	EF330	EF500									T330	T330	T500
3162		97		EF330	EF330										T330	T330	
31512		98		EF330	EF330										T330	T330	

VAUXHALL

ADAM		12		EFB6518L	EFB4018L	EX357	TF650L	BC	TF400L	FX650	BC	FX400	NF659	NF409				
AGILA		00	08	EF500	EF450	EF330	TF500L	A/D	TF450L	FX500	A/D	FX450	NF500	NF450	T500	T450	T330	
			08	EF550	EF450	EX252	TF550L	A/D	TF450L	FX550	A/D	FX450	NF550	NF450	T550	T450		
AMPERA		11		EFB6518L	EFB6518R		TF650L	BC	TF650R	FX650	BC	FX650	NF659	NF659				
ANTARA		06		EF600	EF400	EX305	TF600L	A/D	TF400L	FX600	A/D	FX400	NF600	NF400	T600	T400		
ARENA		98	01	EF500	EF500		TF500L	A/D	TF500L	FX500	A/D	FX500	NF500	NF500	T500	T500		
ASTRA		79	82	EF400	EF400		TF400L	A/D	TF400L	FX400	A/D	FX400	NF400	NF400	T400	T400		
			91	98	EF450	EF450		TF450L	A/D	TF450L	FX450	A/D	FX450	NF450	NF450	T450	T450	
			98	05	EF500	EF480		TF500L	A/D	TF480L	FX500	A/D	FX480	NF500	NF480	T500	T480	
			79	86	EF400	EF400	EF500	TF400L	A/D	TF400L	FX400	A/D	FX400	NF400	NF400	T400	T400	T500
			84	98	EF450	EF450	EF400	TF450L	A/D	TF450L	FX450	A/D	FX450	NF450	NF450	T450	T450	T400
			98	04	EF500	EF480	EX404	TF500L	A/D	TF480L	FX500	A/D	FX480	NF500	NF480	T500	T480	
			04	10	EFB556	EFB456	EX308	TF550L	BC	TF450L	FX550	BC+E	FX450	NF556	NF456			
			10		EFB6518L	EFB6518R	EX310	TF650L	BC	TF650R	FX650	BC	FX650	NF659	NF659			
			79	86	EF400	EF400	EF330	TF400L	A/D	TF400L	FX400	A/D	FX400	NF400	NF400	T400	T400	T330
			84	98	EF450	EF450	EF330	TF450L	A/D	TF450L	FX450	A/D	FX450	NF450	NF450	T450	T450	T330
			98	05	EF500	EF480	EX282	TF500L	A/D	TF480L	FX500	A/D	FX480	NF500	NF480	T500	T480	
			04	10	EFB556	EFB456	EX308	TF550L	BC	TF450L	FX550	BC+E	FX450	NF556	NF456			

			TRICO Exact Fit			TRICO Force			TRICO Flex			TRICO Neoform		TRICO		
--	--	--	------------------------	--	--	--------------------	--	--	-------------------	--	--	----------------------	--	--------------	--	--



...VAUXHALL

Model	Year	Month	TRICO Exact Fit	TRICO Force	TRICO Flex	TRICO Neoform	TRICO										
...ASTRA	10		EFB6518L	EFB6518R	EX310	TF650L	BC	TF650R	FX650	BC	FX650	NF659	NF659				
	00	05	EF500	EF480		TF500L	A/D	TF480L	FX500	A/D	FX480	NF500	NF480	T500	T480		
		05	10	EFB556	EFB456	EX230	TF550L	BC	TF450L	FX550	BC+E	FX450	NF556	NF456			
		12		EFB7318L	EFB6018R	EX310	TF730L	BC	TF600R	FX730	BC	FX600	NF739	NF609			
		87	01	EF450	EF450		TF450L	A/D	TF450L	FX450	A/D	FX450	NF450	NF450	T450	T450	
ASTRAMAX		01	05	EF500	EF480		TF500L	A/D	TF480L	FX500	A/D	FX480	NF500	NF480	T500	T480	
		05	10	EFB556	EFB456		TF550L	BC	TF450L	FX550	BC+E	FX450	NF556	NF456			
		85	94	EF450	EF450		TF450L	A/D	TF450L	FX450	A/D	FX450	NF450	NF450	T450	T450	
	ASTRAVAN	91	98	EF450	EF450		TF450L	A/D	TF450L	FX450	A/D	FX450	NF450	NF450	T450	T450	
		98	06	EF500	EF480		TF500L	A/D	TF480L	FX500	A/D	FX480	NF500	NF480	T500	T480	
BELMONT		05		EFB556	EFB486	EX308	TF550L	BC	TF480L	FX550	BC+E	FX480	NF556	NF486			
		85	91	EF450	EF450		TF450L	A/D	TF450L	FX450	A/D	FX450	NF450	NF450	T450	T450	
	BRAVA	90	02	EF450	EF450		TF450L	A/D	TF450L	FX450	A/D	FX450	NF450	NF450	T450	T450	
	CALIBRA	90	97	EF480	EF480		TF480L	A/D	TF480L	FX480	A/D	FX480	NF480	NF480	T480	T480	
	CARLTON	78	86	EF450	EF450		TF450L	A/D	TF450L	FX450	A/D	FX450	NF450	NF450	T450	T450	
CASCADA		86	94	EF480	EF480		TF480L	A/D	TF480L	FX480	A/D	FX480	NF480	NF480	T480	T480	
		86	94	EF450	EF450	EF400	TF450L	A/D	TF450L	FX450	A/D	FX450	NF450	NF450	T450	T450	T400
		86	94	EF480	EF480	EF330	TF480L	A/D	TF480L	FX480	A/D	FX480	NF480	NF480	T480	T480	T330
		13		EFB6518L	EFB6518L		TF650L	BC	TF650L	FX650	BC	FX650	NF659	NF659			
	CAVALIER	75	81	EF450	EF450										T450	T450	
CAVALIER CC		81	88	EF450	EF450		TF450L	A/D	TF450L	FX450	A/D	FX450	NF450	NF450	T450	T450	
		88	95	EF480	EF480								NF480	NF480	T480	T480	
		81	88	EF450	EF450	EF450	TF450L	A/D	TF450L	FX450	A/D	FX450	NF450	NF450	T450	T450	T450
		88	95	EF480	EF480	EF480	TF480L	A/D	TF480L	FX480	A/D	FX480	NF480	NF480	T480	T480	T480
		81	88	EF450	EF450	EF380	TF450L	A/D	TF450L	FX450	A/D	FX450	NF450	NF450	T450	T450	T380
CHEVETTE		75	81	EF450	EF450		TF450L	A/D	TF450L	FX450	A/D	FX450	NF450	NF450	T450	T450	
		75	88	EF450	EF450		TF450L	A/D	TF450L	FX450	A/D	FX450	NF450	NF450	T450	T450	
		75	81	EF450	EF450		TF450L	A/D	TF450L	FX450	A/D	FX450	NF450	NF450	T450	T450	
		75	88	EF450	EF450		TF450L	A/D	TF450L	FX450	A/D	FX450	NF450	NF450	T450	T450	
		75	81	EF450	EF450		TF450L	A/D	TF450L	FX450	A/D	FX450	NF450	NF450	T450	T450	T450
COMBO Van		75	85	EF400*	EF400*										T400*	T400*	
		75	85	EF400*	EF400*										T400*	T400*	
		76	85	EF400*	EF400*										T400*	T400*	
		01	12	EF500	EF430		TF500L	A/D	TF430L	FX500	A/D	FX430	NF500	NF430	T500	T430	
		12		EFB6018L	EFB4018L	EX358	TF600L	BC	TF400L	FX600	BC	FX400	NF609	NF409			
CORSA		93	00	EF450	EF450	EF350	TF450L	A/D	TF450L	FX450	A/D	FX450	NF450	NF450	T450	T450	T350
		00	06	EF500	EF450	EX404	TF500L	A/D	TF450L	FX500	A/D	FX450	NF500	NF450	T500	T450	
		06	14	EFB6517L	EFB4017L	EX300	TF650L	BC	TF400L	FX650	BC	FX400	NF657	NF407			
		15		EFB6517L	EFB4017L	EX308	TF650L	BC	TF400L	FX650	BC	FX400	NF657	NF407			
		98	99	EF450	EF450		TF450L	A/D	TF450L	FX450	A/D	FX450	NF450	NF450	T450	T450	
FRONTERA		94	00	EF450	EF450		TF450L	A/D	TF450L	FX450	A/D	FX450	NF450	NF450	T450	T450	
		00	06	EF500	EF450	EX404	TF500L	A/D	TF450L	FX500	A/D	FX450	NF500	NF450	T500	T450	
		06		EFB6517L	EFB4017L	EX300	TF650L	BC	TF400L	FX650	BC	FX400	NF657	NF407			
		92	04	EF480	EF480	EF280	TF480L	A/D	TF480L	FX480	A/D	FX480	NF480	NF480	T480	T480	T280
		08		HF600	HF450		TF600L	A/D	TF450L	FX600	A/D	FX450	NF600	NF450			
MAGNUM		08		HF600	HF450	EFB5017L	TF600L	A/D	TF450L	FX600	A/D	FX450	NF600	NF450			
		08		HF600	HF450	EX300	TF600L	A/D	TF450L	FX600	A/D	FX450	NF600	NF450			
		08		HF600	HF450		TF600L	A/D	TF450L	FX600	A/D	FX450	NF600	NF450			
		73	81	EF350	EF350		TF350L	A/D	TF350L	FX350	A/D	FX350	NF350	NF350	T350	T350	



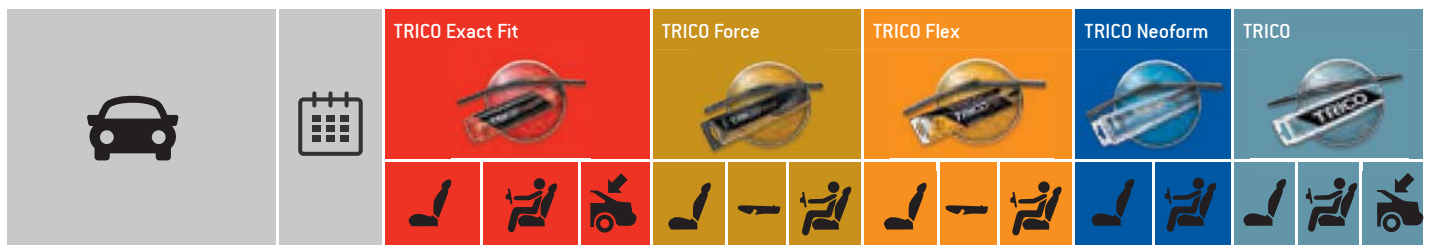

...VAUXHALL

...MAGNUM		73	81	EF350	EF350		TF350L	A/D	TF350L	FX350	A/D	FX350	NF350	NF350	T350	T350	
		73	75	EF350	EF350		TF350L	A/D	TF350L	FX350	A/D	FX350	NF350	NF350	T350	T350	
MERIVA		03	10	EF600	EF600	EX404	TF600L	A/D	TF600R	FX600	A/D	FX600	NF600	NF600	T600	T600	
		10		EFB7018L	EFB5318R	EX404	TF700L	BC	TF550R	FX700	BC	FX550	NF709	NF539			
MIDI		84	97	EF450	EF450	EF400	TF450L	A/D	TF450L	FX450	A/D	FX450	NF450	NF450	T450	T450	T400
MOKKA		12		EFB6518L	EFB3518L		TF650L	A/D	TF350L	FX650	A/D	FX350	NF659	NF359			
MONTEREY		91	99	EF500	EF500	EF380	TF500L	A/D	TF500L	FX500	A/D	FX500	NF500	NF500	T500	T500	T380
MOVANO		98	10	EF603	EF603												
		10		EF650	EF650		TF650L	A/D	TF650L	FX650	A/D	FX650	NF650	NF650	T650	T650	
NOVA		82	93	EF400	EF400		TF400L	A/D	TF400L	FX400	A/D	FX400	NF400	NF400	T400	T400	
		83	93	EF400	EF400	EF400	TF400L	A/D	TF400L	FX400	A/D	FX400	NF400	NF400	T400	T400	T400
NOVAVAN		90	94	EF400	EF400		TF400L	A/D	TF400L	FX400	A/D	FX400	NF400	NF400	T400	T400	
OMEGA		94	03	EF600	EF480		TF600L	A/D	TF480L	FX600	A/D	FX480	NF600	NF480	T600	T480	
		94	04	EF600	EF480	EF350	TF600L	A/D	TF480L	FX600	A/D	FX480	NF600	NF480	T600	T480	T350
RASCAL		86	93	EF400	EF400		TF400L	A/D	TF400L	FX400	A/D	FX400	NF400	NF400	T400	T400	
ROYALE		78	87	EF450	EF450		TF450L	A/D	TF450L	FX450	A/D	FX450	NF450	NF450	T450	T450	
		78	86	EF450	EF450		TF450L	A/D	TF450L	FX450	A/D	FX450	NF450	NF450	T450	T450	
SENATOR		78	87	EF450	EF450		TF450L	A/D	TF450L	FX450	A/D	FX450	NF450	NF450	T450	T450	
		87	93	EF480	EF480		TF480L	A/D	TF480L	FX480	A/D	FX480	NF480	NF480	T480	T480	
SIGNUM		02	08	EF600	EF480	EX404	TF600L	A/D	TF480L	FX600	A/D	FX480	NF600	NF480	T600	T480	
SINTRA		96	99	EF600	EF600	EF400	TF600L	A/D	TF600R	FX600	A/D	FX600	NF600	NF600	T600	T600	T400
TIGRA		94	00	EF450	EF450	EF500	TF450L	A/D	TF450L	FX450	A/D	FX450	NF450	NF450	T450	T450	T500
		04	09	EF500	EF450		TF500L	A/D	TF450L	FX500	A/D	FX450	NF500	NF450	T500	T450	
VECTRA		95	02	EF480	EF480		TF480L	A/D	TF480L	FX480	A/D	FX480	NF480	NF480	T480	T480	
		02	08	EF600	EF480		TF600L	A/D	TF480L	FX600	A/D	FX480	NF600	NF480	T600	T480	
		95	02	EF480	EF480	EF480	TF480L	A/D	TF480L	FX480	A/D	FX480	NF480	NF480	T480	T480	T480
		02	05	EF600	EF480	EX404	TF600L	A/D	TF480L	FX600	A/D	FX480	NF600	NF480	T600	T480	
		05	08	EF600	EF480	EX400	TF600L	A/D	TF480L	FX600	A/D	FX480	NF600	NF480	T600	T480	
		95	02	EF480	EF480	EF330	TF480L	A/D	TF480L	FX480	A/D	FX480	NF480	NF480	T480	T480	T330
		02	08	EF600	EF480		TF600L	A/D	TF480L	FX600	A/D	FX480	NF600	NF480	T600	T480	
VENTORA		69	76	EF380	EF380		TF350L	A/D	TF350L	FX350	A/D	FX350	NF350	NF350	T380	T380	
VICTOR		67	76	EF450	EF450		TF450L	A/D	TF450L	FX450	A/D	FX450	NF450	NF450	T450	T450	
		68	76	EF450	EF450		TF450L	A/D	TF450L	FX450	A/D	FX450	NF450	NF450	T450	T450	
VIVA		63	79	EF350	EF350		TF350L	A/D	TF350L	FX350	A/D	FX350	NF350	NF350	T350	T350	
		65	79	EF350	EF350		TF350L	A/D	TF350L	FX350	A/D	FX350	NF350	NF350	T350	T350	
		71	75	EF350	EF350		TF350L	A/D	TF350L	FX350	A/D	FX350	NF350	NF350	T350	T350	
VIVA		15		EF600	EF350		TF600L	A/D	TF350L	FX600	A/D	FX350	NF600	NF350	T600	T350	
VIVARO		01		EF600	EF530		TF600L	A/D	TF530L	FX600	A/D	FX530	NF600	NF530	T600	T530	
ZAFIRA		98	05	EF600	EF600	EX404	TF600L	A/D	TF600R	FX600	A/D	FX600	NF600	NF600	T600	T600	
		05	12	EFB7017L	EFB5517R	EX353	TF700L	BC	TF550R	FX700	BC	FX550	NF707	NF557			
ZAFIRA Tourer		12		EFB8018L	EFB7018R		TF800L	BC		FX800	BC	FX700	NF809	NF709			

VOLVO

66		75	78	EF330	EF330										T330	T330	
140		66	75	EF400	EF400		TF400L	A/D	TF400L	FX400	A/D	FX400	NF400	NF400	T400	T400	
		66	75	EF400	EF400	EF330	TF400L	A/D	TF400L	FX400	A/D	FX400	NF400	NF400	T400	T400	T330
164		68	74	EF400	EF400		TF400L	A/D	TF400L	FX400	A/D	FX400	NF400	NF400	T400	T400	



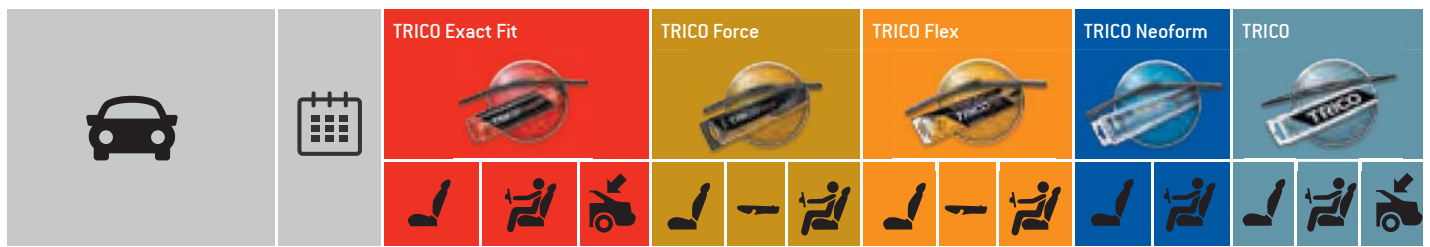

...VOLVO

240		74	93	EF400	EF400		TF400L	A/D	TF400L	FX400	A/D	FX400	NF400	NF400	T400	T400	
		74	93	EF400	EF400	EF330	TF400L	A/D	TF400L	FX400	A/D	FX400	NF400	NF400	T400	T400	T330
260		74	82	EF400	EF400	EF330	TF400L	A/D	TF400L	FX400	A/D	FX400	NF400	NF400	T400	T400	T330
		75	82	EF400	EF400	EF330	TF400L	A/D	TF400L	FX400	A/D	FX400	NF400	NF400	T400	T400	T330
		77	78	EF400	EF400		TF400L	A/D	TF400L	FX400	A/D	FX400	NF400	NF400	T400	T400	
340-360		82	91	EF450	EF450		TF450L	A/D	TF450L	FX450	A/D	FX450	NF450	NF450	T450	T450	
		75	91	EF450	EF450	EF450	TF450L	A/D	TF450L	FX450	A/D	FX450	NF450	NF450	T450	T450	T450
440		88	96	EF530	EF530	EF500	TF530L	A/D	TF530L	FX530	A/D	FX530	NF530	NF530	T530	T530	T500
460		88	96	EF530	EF530	EF500	TF530L	A/D	TF530L	FX530	A/D	FX530	NF530	NF530	T530	T530	T500
480		86	96	EF530	EF530		TF530L	A/D	TF530L	FX530	A/D	FX530	NF530	NF530	T530	T530	
740		83	92	EF500	EF500		TF500L	A/D	TF500L	FX500	A/D	FX500	NF500	NF500	T500	T500	
		84	92	EF500	EF500	EF350	TF500L	A/D	TF500L	FX500	A/D	FX500	NF500	NF500	T500	T500	T350
760		81	92	EF500	EF500		TF500L	A/D	TF500L	FX500	A/D	FX500	NF500	NF500	T500	T500	
		82	92	EF500	EF500	EF350	TF500L	A/D	TF500L	FX500	A/D	FX500	NF500	NF500	T500	T500	T350
780		86	90	EF500	EF500		TF500L	A/D	TF500L	FX500	A/D	FX500	NF500	NF500	T500	T500	
850		91	97	EF530	EF530		TF530L	A/D	TF530L	FX530	A/D	FX530	NF530	NF530	T530	T530	
		92	97	EF530	EF530	EF430	TF530L	A/D	TF530L	FX530	A/D	FX530	NF530	NF530	T530	T530	
940		90	98	EF500	EF500		TF500L	A/D	TF500L	FX500	A/D	FX500	NF500	NF500	T500	T500	
		90	98	EF500	EF500	EF350	TF500L	A/D	TF500L	FX500	A/D	FX500	NF500	NF500	T500	T500	T350
960		90	96	EF530	EF530		TF530L	A/D	TF530L	FX530	A/D	FX530	NF530	NF530	T530	T530	
		90	96	EF530	EF530	EF350	TF530L	A/D	TF530L	FX530	A/D	FX530	NF530	NF530	T530	T530	T350
C30		06	09	EFB6518L	EFB5018L	EX400	TF650L	BC	TF500L	FX650	BC	FX500	NF659	NF509			
		10		EFB6518L	EFB5018L		TF650L	BC	TF500L	FX650	BC	FX500	NF659	NF509			
C70		97	02	EF530	EF530		TF530L	A/D	TF530L	FX530	A/D	FX530	NF530	NF530	T530	T530	
		98	05	EF530	EF530		TF530L	A/D	TF530L	FX530	A/D	FX530	NF530	NF530	T530	T530	
		06		EFB6518L	EFB5018L		TF650L	BC	TF500L	FX650	BC	FX500	NF659	NF509			
P 1800		62	73	EF330	EF330										T330	T330	
S40		95	03	EF530	EF500		TF530L	A/D	TF480L	FX530	A/D	FX480	NF530	NF500	T530	T500	
		04	05	EFB656	EFB486		TF650L	BC	TF480L	FX650	BC+E	FX480	NF656	NF486			
		05		EFB6518L	EFB4818L		TF650L	BC	TF480L	FX650	BC	FX480	NF659	NF489			
S60		00	05	EF600	EF550		TF600L	A/D	TF550L	FX600	A/D	FX550	NF600	NF550	T600	T550	
		05	09	EFB6017L	EFB5517L		TF600L	BC	TF550L	FX600	BC	FX550	NF607	NF557			
		10		EFB6518L	EFB5018L		TF650L	BC	TF500L	FX650	BC	FX500	NF659	NF509			
S70		96	00	EF530	EF530		TF530L	A/D	TF530L	FX530	A/D	FX530	NF530	NF530	T530	T530	
S80		98	03	EF600	EF550		TF600L	A/D	TF550L	FX600	A/D	FX550	NF600	NF550	T600	T550	
		04	06	EFB6017L	EFB5517L		TF600L	BC	TF550L	FX600	BC	FX550	NF607	NF557			
		06		EFB6518L	EFB5018L		TF650L	BC	TF500L	FX650	BC	FX500	NF659	NF509			
S90		96	98	EF530	EF530		TF530L	A/D	TF530L	FX530	A/D	FX530	NF530	NF530	T530	T530	
V40		12		EFB6518L	EFB4518L	EX304	TF650L	BC	TF450L	FX650	BC	FX450	NF659	NF459			
		95	01	EF530	EF500	EF400	TF530L	A/D	TF500L	FX530	A/D	FX500	NF530	NF500	T530	T500	T400
		01	04	EF530	EF500		TF530L	A/D	TF500L	FX530	A/D	FX500	NF530	NF500	T530	T500	
V50		04	05	EFB656	EFB486	EX355	TF650L	BC	TF480L	FX650	BC+E	FX480	NF656	NF486			T350
		05		EFB6518L	EFB4818L	EX355	TF650L	BC	TF480L	FX650	BC	FX480	NF659	NF489			T350
V60		10		EFB6518L	EFB5018L	EX301	TF650L	BC	TF500L	FX650	BC	FX500	NF659	NF509			
V70		96	00	EF530	EF530	EF430	TF530L	A/D	TF530L	FX530	A/D	FX530	NF530	NF530	T530	T530	
		00	03	EF600	EF550		TF600L	A/D	TF550L	FX600	A/D	FX550	NF600	NF550	T600	T550	



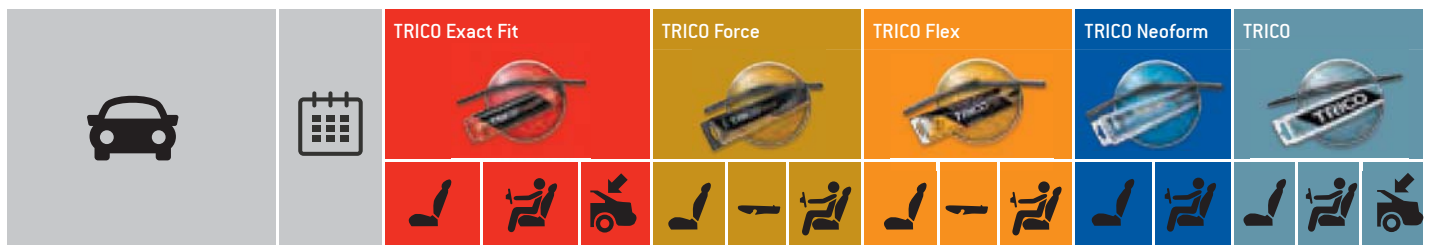

...VOLVO

V70	04	06	EFB6017L	EFB5517L	EX380	TF600L	BC	TF550L	FX600	BC	FX550	NF607	NF557			
	06		EFB6518L	EFB5018L	EX333	TF650L	BC	TF500L	FX650	BC	FX500	NF659	NF509			
V90	96	98	EF530	EF530	EF350	TF530L	A/D	TF530L	FX530	A/D	FX530	NF530	NF530	T530	T530	T350
XC60	08	11	EFB6518L	EFB5018L	EX333	TF650L	BC	TF500L	FX650	BC	FX500	NF659	NF509			
	11		EFB6518L	EFB5018L	EX353	TF650L	BC	TF500L	FX650	BC	FX500	NF659	NF509			
XC70	07		EFB6518L	EFB5018L	EX333	TF650L	BC	TF500L	FX650	BC	FX500	NF659	NF509			
XC70 CROSS COUNTRY	00	03	EF600	EF550		TF600L	A/D	TF550L	FX600	A/D	FX550	NF600	NF550	T600	T550	
	04	07	EFB6017L	EFB5517L	EX380	TF600L	BC	TF550L	FX600	BC	FX550	NF607	NF557			
	07		EFB6518L	EFB5018L	EX333	TF650L	BC	TF500L	FX650	BC	FX500	NF659	NF509			
XC90	02	04	EF600	EF550	EX380	TF600L	A/D	TF550L	FX600	A/D	FX550	NF600	NF550	T600	T550	
	05	07	EFB6017L	EFB5517L	EX380	TF600L	BC	TF550L	FX600	BC	FX550	NF607	NF557			
	07	11	EFB6017L	EFB5517L	EX400	TF600L	BC	TF550L	FX600	BC	FX550	NF607	NF557			
	11	14	EFB6017L	EFB5517L	EX353	TF600L	BC	TF550L	FX600	BC	FX550	NF607	NF557			
	15		EFB6017L	EFB5017L	EX356	TF600L	BC	TF500L	FX600	BC	FX550	NF6013	NF5013			

VW

1500		61	73	EF380	EF380		TF350L	A/D	TF350L	FX350	A/D	FX350	NF350	NF350	T380	T380	
		65	73	EF380	EF380		TF350L	A/D	TF350L	FX350	A/D	FX350	NF350	NF350	T380	T380	
		61	73	EF380	EF380		TF350L	A/D	TF350L	FX350	A/D	FX350	NF350	NF350	T380	T380	
AMAROK		10	12	EF600	EF600		TF600L	A/D	TF600L	FX600	A/D	FX600	NF600	NF600	T600	T600	
		13		EFB6017L	EFB6017L		TF600L	BC	TF600L	FX600	BC	FX600	NF6013	NF6013			
BEETLE		98	10	EF530	EF530		TF530L	A/D	TF530L	FX530	A/D	FX530	NF530	NF530	T530	T530	
		11		EFB5317L	EFB5317L		TF530L	BC	TF530L	FX530	BC	FX530	NF5313	NF5313			
		64	81	EF380	EF380		TF350L	A/D	TF350L	FX350	A/D	FX350	NF350	NF350	T380	T380	
		02	10	EF530	EF530		TF530L	A/D	TF530L	FX530	A/D	FX530	NF530	NF530	T530	T530	
BORA		98	02	EF530	EF480		TF530L	A/D	TF480L	FX530	A/D	FX480	NF530	NF480	T530	T480	
		02	05	EFB536	EFB436		TF530L	BC	TF430L	FX530	BC+E	FX430	NF536	NF436			
		98	02	EF530	EF480	EF380	TF530L	A/D	TF480L	FX530	A/D	FX480	NF530	NF480	T530	T480	T380
		02	05	EFB536	EFB436	EF380	TF530L	BC	TF430L	FX530	BC+E	FX430	NF536	NF436			T380
CADDY		95	04	EF500	EF450	EF280	TF500L	A/D	TF450L	FX500	A/D	FX450	NF500	NF450	T500	T450	T280
		04	06	EFB606	EFB456	EX400	TF600L	BC	TF450L	FX600	BC+E	FX450	NF606	NF456			
		07	14	EFB6018L	EFB4518L	EX400	TF600L	BC	TF450L	FX600	BC	FX450	NF609	NF459			
		15		EFB6018L	EFB4518L	EX405	TF600L	BC	TF450L	FX600	BC	FX450	NF609	NF459			
CADDY Van		82	92	EF400	EF400		TF400L	A/D	TF400L	FX400	A/D	FX400	NF400	NF400	T400	T400	
		95	04	EF500	EF450		TF500L	A/D	TF450L	FX500	A/D	FX450	NF500	NF450	T500	T450	
		04	06	EFB606	EFB456	EX400	TF600L	BC	TF450L	FX600	BC+E	FX450	NF606	NF456			
		07	14	EFB6018L	EFB4518L	EX400	TF600L	BC	TF450L	FX600	BC	FX450	NF609	NF459			
		15		EFB6018L	EFB4518L	EX405	TF600L	BC	TF450L	FX600	BC	FX450	NF609	NF459			
CC		11	12	EFB6018L	EFB4818L		TF600L	BC	TF480L	FX600	BC	FX480	NF609	NF489			
		13		EFB6017L	EFB4817L		TF600L	BC	TF480L	FX600	BC	FX480	NF6013	NF4813			
CORRADO		88	95	EF480	EF480	EF450	TF480L	A/D	TF480L	FX480	A/D	FX480	NF480	NF480	T480	T480	T450
CRAFTER 30-35		06		EFB6517L	EFB6017L		TF650L	BC	TF600L	FX650	BC	FX600	NF657	NF607			
CRAFTER 30-50		06		EFB6517L	EFB6017L		TF650L	BC	TF600L	FX650	BC	FX600	NF657	NF607			
DERBY		77	84	EF400	EF400		TF400L	A/D	TF400L	FX400	A/D	FX400	NF400	NF400	T400	T400	
EOS		06	13	EFB6018L	EFB4818L		TF600L	BC	TF480L	FX600	BC	FX480	NF609	NF489			
		14		EFB6017L	EFB4517L		TF600L	BC	TF450L	FX600	BC	FX450	NF6013	NF4513			
FOX		03	11	EF550	EF380		TF550L	A/D	TF350L	FX550	A/D	FX350	NF550	NF350	T550	T380	



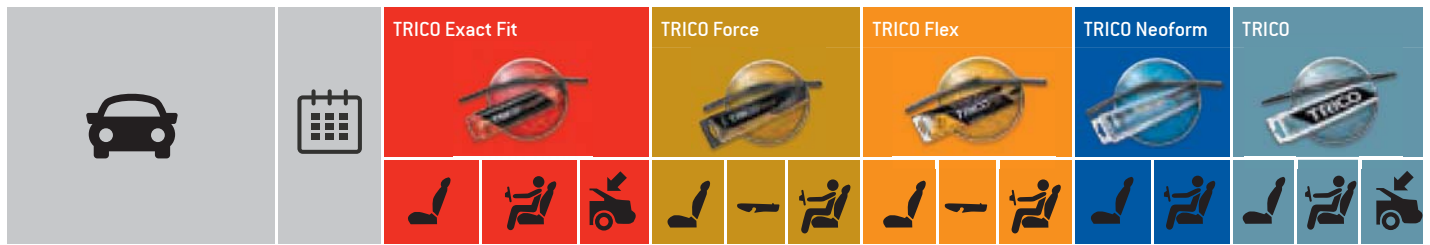

...VW																		
GOLF		74	85	EF400	EF400	EF400	TF400L	A/D	TF400L	FX400	A/D	FX400	NF400	NF400	T400	T400	T400	
		83	92	EF450	EF450	EF400	TF450L	A/D	TF450L	FX450	A/D	FX450	NF450	NF450	T450	T450	T400	
		91	02	EF530	EF480	EF350	TF530L	A/D	TF480L	FX530	A/D	FX480	NF530	NF480	T530	T480	T350	
		02	05	EFB536	EFB436	EF350	TF530L	BC	TF430L	FX530	BC+E	FX430	NF536	NF436				T350
		05	06	EFB606	EFB486	EX333	TF600L	BC	TF480L	FX600	BC+E	FX480	NF606	NF486				
		06	08	EFB6018L	EFB4818L	EX333	TF600L	BC	TF480L	FX600	BC	FX480	NF609	NF489				
		08	12	EFB6018L	EFB4518L	EX284	TF600L	BC	TF480L	FX600	BC	FX480	NF609	NF489				
		12		EFB6517L	EFB4517L	EX284	TF650L	BC	TF450L	FX650	BC	FX450	NF6513	NF4513				
		93	02	EF530	EF480	EF330	TF530L	A/D	TF480L	FX530	A/D	FX480	NF530	NF480	T530	T480	T330	
		02	06	EFB536	EFB436	EF380	TF530L	BC	TF430L	FX530	BC+E	FX430	NF536	NF436				T380
GOLF PLUS		07	08	EFB6018L	EFB4818L	EX333	TF600L	BC	TF480L	FX600	BC	FX480	NF609	NF489				
		09	12	EFB6018L	EFB4518L	EX284	TF600L	BC	TF450L	FX600	BC	FX450	NF609	NF459				
		13		EFB6517L	EFB4517L	EX284	TF650L	BC	TF450L	FX650	BC	FX450	NF6513	NF4513				
		79	93	EF400	EF400		TF400L	A/D	TF400L	FX400	A/D	FX400	NF400	NF400	T400	T400		
		93	02	EF530	EF480		TF530L	A/D	TF480L	FX530	A/D	FX480	NF530	NF480	T530	T480		
		13		EFB6017L	EFB4517L		TF600L	BC	TF450L	FX600	BC	FX450	NF6013	NF4513				
		05	09	EFB706	EFB706	EX333	TF700L	BC	TF700R	FX700	BC+E	FX700	NF706	NF706				
		09		EFB706	EFB706	EX334	TF700L	BC	TF700R	FX700	BC+E	FX700	NF706	NF706				
		14		EFB7017L	EFB4017L	EX284	TF700L	BC	TF400L	FX700	BC	FX400	NF7013	NF4013				
		JETTA		78	84	EF400	EF400		TF400L	A/D	TF400L	FX400	A/D	FX400	NF400	NF400	T400	T400
83	92			EF450	EF450		TF450L	A/D	TF450L	FX450	A/D	FX450	NF450	NF450	T450	T450		
05	06			EFB606	EFB486		TF600L	A/D	TF480L	FX600	A/D	FX480	NF606	NF486				
06	11			EFB6018L	EFB4818L		TF600L	BC	TF480L	FX600	BC	FX480	NF609	NF489				
12				EFB6017L	EFB4517L		TF600L	BC	TF450L	FX600	BC	FX450	NF6013	NF4513				
K 70		70	74	EF450	EF450		TF450L	A/D	TF450L	FX450	A/D	FX450	NF450	NF450	T450	T450		
KARMANN GHIA		61	74	EF330	EF330										T330	T330		
		57	74	EF330	EF330											T330	T330	
LT 28-35		75	96	EF480	EF480		TF480L	A/D	TF480L	FX480	A/D	FX480	NF480	NF480	T480	T480		
		96	06	EF600	EF550		TF600L	A/D	TF550L	FX600	A/D	FX550	NF600	NF550	T600	T550		
LT 28-46		96	06	EF600	EF550		TF600L	A/D	TF550L	FX600	A/D	FX550	NF600	NF550	T600	T550		
LT 40-55		75	96	EF480	EF480		TF480L	A/D	TF480L	FX480	A/D	FX480	NF480	NF480	T480	T480		
LUPO		98	99	EF480	EF480	EF280	TF480L	A/D	TF480L	FX480	A/D	FX480	NF480	NF480	T480	T480	T280	
		GTI	00	03	EFB486	EFB456		TF480L	BC	TF450L	FX480	BC+E	FX450	NF486	NF456			
MULTIVAN		03	05	EFB606	EFB606	EX400	TF600L	BC	TF600L	FX600	BC+E	FX600	NF606	NF606				
		05	13	EF600	EF600	EX400	TF600L	A/D	TF600L	FX600	A/D	FX600	NF600	NF600	T600	T600		
		14		EFB6017L	EFB6017L	EX400	TF600L	BC	TF600L	FX600	BC	FX600	NF6013	NF6013				
PASSAT		84	88	EF450	EF450		TF450L	A/D	TF450L	FX450	A/D	FX450	NF450	NF450	T450	T450		
		88	01	EF530	EF530		TF530L	A/D	TF530L	FX530	A/D	FX530	NF530	NF530	T530	T530		
		02	05	EFB536	EFB486		TF530L	BC	TF480L	FX530	BC+E	FX480	NF536	NF486				
		05	12	EFB6018L	EFB4818L		TF600L	BC	TF480L	FX600	BC	FX480	NF609	NF489				
		13	14	EFB6017L	EFB4817L		TF600L	BC	TF480L	FX600	BC	FX480	NF6013	NF4813				
		15		EFB6517L	EFB4817L		TF650L	BC	TF480L	FX650	BC	FX480	NF6513	NF4813				
		73	80	EF400	EF400	EF400	TF400L	A/D	TF400L	FX400	A/D	FX400	NF400	NF400	T400	T400	T400	
		79	89	EF450	EF450		TF450L	A/D	TF450L	FX450	A/D	FX450	NF450	NF450	T450	T450		
	73	80	EF400	EF400		TF400L	A/D	TF400L	FX400	A/D	FX400	NF400	NF400	T400	T400			
	80	88	EF450	EF450	EF330	TF450L	A/D	TF450L	FX450	A/D	FX450	NF450	NF450	T450	T450	T330		



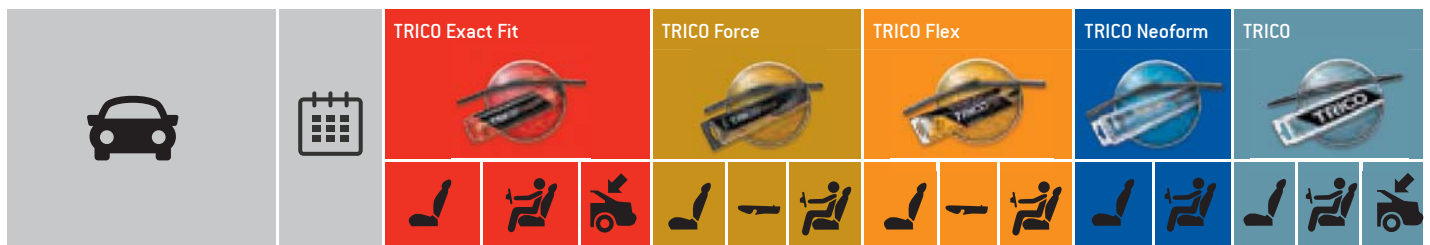

...VW																	
...PASSAT		88	01	EF530	EF530		TF530L	A/D	TF530L	FX530	A/D	FX530	NF530	NF530	T530	T530	T400
		02	05	EFB536	EFB486	EF380	TF530L	BC	TF480L	FX530	BC+E	FX480	NF536	NF486			T380
		05	12	EFB6018L	EFB4818L	EX304	TF600L	BC	TF480L	FX600	BC	FX480	NF609	NF489			
		12	14	EFB6017L	EFB4817L	EX304	TF600L	BC	TF480L	FX600	BC	FX480	NF6013	NF4813			
		15		EFB6517L	EFB4817L	EX356	TF650L	BC	TF480L	FX650	BC	FX480	NF6513	NF4813			
PASSAT CC		08	12	EFB6018L	EFB4818L		TF600L	BC	TF480L	FX600	BC	FX480	NF609	NF489			
PHAETON		02		EFB606	EFB456		TF600L	BC	TF450L	FX600	BC+E	FX450	NF606	NF456			
POLO		85	94	EF400	EF400		TF400L	A/D	TF400L	FX400	A/D	FX400	NF400	NF400	T400	T400	
		95	05	EF530	EF450		TF530L	A/D	TF450L	FX530	A/D	FX450	NF530	NF450	T530		
		75	94	EF400	EF400	EF280	TF400L	A/D	TF400L	FX400	A/D	FX400	NF400	NF400	T400	T400	T280
		94	99	EF480	EF480	EF280	TF480L	A/D	TF480L	FX480	A/D	FX480	NF480	NF480	T480	T480	T280
		99	01	EF480	EF480		TF480L	A/D	TF480L	FX480	A/D	FX480	NF480	NF480	T480	T480	
		01	05	EFB536	EFB436	EX333	TF530L	BC	TF430L	FX530	BC+E	FX430	NF536	NF436			
		06	09	EFB5318L	EFB4818L	EX333	TF530L	BC	TF480L	FX530	BC	FX480	NF539	NF489			
		09		EFB6017L	EFB4017L	EX284	TF600L	BC	TF400L	FX600	BC	FX400	NF6013	NF4013			
		97	01	EF530	EF450		TF530L	A/D	TF450L	FX530	A/D	FX450	NF530	NF450	T530	T450	
		81	94	EF400	EF400	EF280	TF400L	A/D	TF400L	FX400	A/D	FX400	NF400	NF400	T400	T400	T280
POLO Van		92	99	EF480	EF480		TF480L	A/D	TF480L	FX480	A/D	FX480	NF480	NF480	T480	T480	
QUANTUM		95	05	EF530	EF530	EF400	TF530L	A/D	TF530L	FX530	A/D	FX530	NF530	NF530	T530	T530	T400
SANTANA		81	94	EF450	EF450		TF450L	A/D	TF450L	FX450	A/D	FX450	NF450	NF450	T450	T450	
		85	96	EF450	EF450		TF450L	A/D	TF450L	FX450	A/D	FX450	NF450	NF450	T450	T450	
SCIROCCO		74	80	EF400	EF400		TF400L	A/D	TF400L	FX400	A/D	FX400	NF400	NF400	T400	T400	
		80	92	EF480	EF480	EF400	TF480L	A/D	TF480L	FX480	A/D	FX480	NF480	NF480	T480	T480	T400
		08		EFB6018L	EFB4818L	EX250	TF600L	BC	TF480L	FX600	BC	FX480	NF609	NF489			
SHARAN		95	00	EF701	EF701	EF400											T400
		01	10	EFB706	EFB706	EF400	TF700L	BC	TF700L	FX700	BC+E	FX700	NF706	NF706			T400
		10		EFB7017L	EFB4017L	EX356	TF700L	BC	TF400L	FX700	BC	FX400	NF7013	NF4013			
TARO		89	97	EF430*	EF430*										T430*	T430*	
TIGUAN		07		EFB6018L	EFB5318L	EX333	TF600L	BC	TF530L	FX600	BC	FX530	NF609	NF539			
TOUAREG		02	10	EFB656	EFB656	EX333	TF650L	BC	TF650L	FX650	BC+E	FX650	NF656	NF656			
		10		EFB656	EFB656	EX334	TF650L	BC	TF650L	FX650	BC+E	FX650	NF656	NF656			
TOURAN		03	05	EFB706	EFB706	EF400	TF700L	BC	TF700R	FX700	BC+E	FX700	NF706	NF706			T400
		05	10	EFB6018L	EFB4518L	EX400	TF600L	BC	TF450L	FX600	BC	FX450	NF609	NF459			
		10		EFB6018L	EFB4518L	EX334	TF600L	BC	TF450L	FX600	BC	FX450	NF609	NF459			
TRANSPORTER		90	03	EF530	EF530	EF450	TF530L	A/D	TF530L	FX530	A/D	FX530	NF530	NF530	T530	T530	T450
		03	13	EF600	EF600	EX400	TF600L	A/D	TF600L	FX600	A/D	FX600	NF600	NF600	T600	T600	
		14		EFB6017L	EFB6017L		TF600L	BC	TF600L	FX600	BC	FX600	NF6013	NF6013			
TRANSPORTER Van		67	79	EF400	EF400		TF400L	A/D	TF400L	FX400	A/D	FX400	NF400	NF400	T400	T400	
		03	13	EF600	EF600	EX400	TF600L	A/D	TF600L	FX600	A/D	FX600	NF600	NF600	T600	T600	
		14		EFB6017L	EFB6017L		TF600L	BC	TF600L	FX600	BC	FX600	NF6013	NF6013			
UP		11		EFB6017L	EFB4017L	EX250	TF600L	BC	TF400L	FX600	BC	FX400	NF6013	NF4013			
VENTO		91	98	EF530	EF480		TF530L	A/D	TF480L	FX530	A/D	FX480	NF530	NF480	T530	T480	
WARTBURG																	
353		66	91	EF400	EF400		TF400L	A/D	TF400L	FX400	A/D	FX400	NF400	NF400	T400	T400	
		67	91	EF400	EF400		TF400L	A/D	TF400L	FX400	A/D	FX400	NF400	NF400	T400	T400	





ZASTAVA

101	73	93	EF280	EF280	EF280									T280	T280	T280
YUGO	80	91	EF280	EF280	EF280									T280	T280	T280
		92	95	EF400	EF400		TF400L	A/D	TF400L	FX400	A/D	FX400	NF400	NF400	T400	T400
YUGO FLORIDA	88	95	EF450	EF450		TF450L	A/D	TF450L	FX450	A/D	FX450	NF450	NF450	T450	T450	

ZAZ

TAVRIJA	89		EF500	EF500	EF330	TF500L	A/D	TF500L	FX500	A/D	FX500	NF500	NF500	T500	T500	T330
---------	----	--	-------	-------	-------	--------	-----	--------	-------	-----	-------	-------	-------	------	------	------



EF280

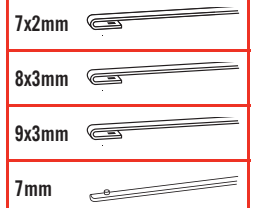

EF330

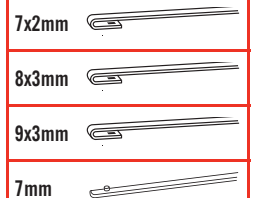

EF350

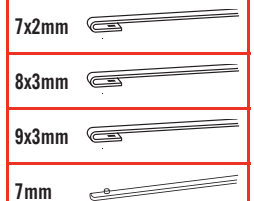

EF380

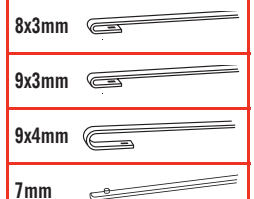

EF400

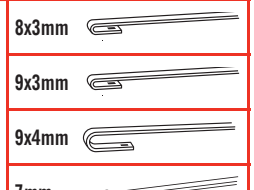

EF430

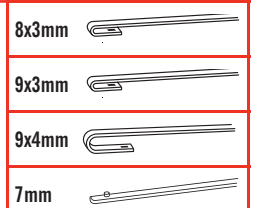

EF450

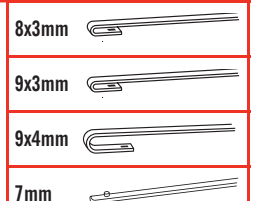
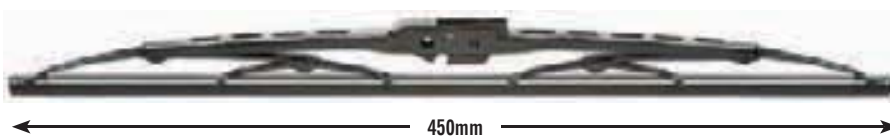



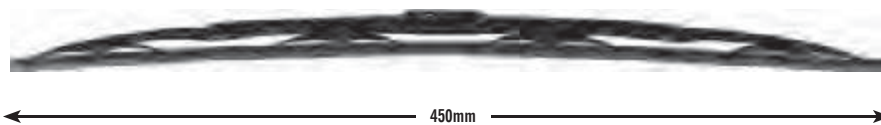

EF453









EF480



- 8x3mm 
- 9x3mm 
- 9x4mm 
- 7mm 

EF500



- 8x3mm 
- 9x3mm 
- 9x4mm 
- 7mm 

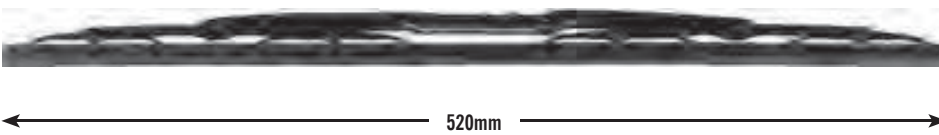

EF521

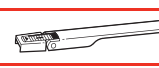

- 

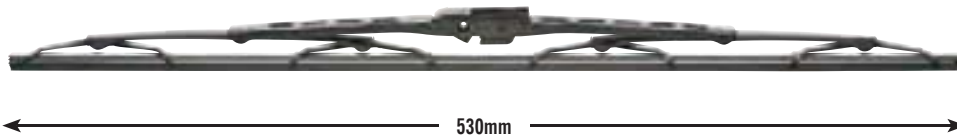

EF530

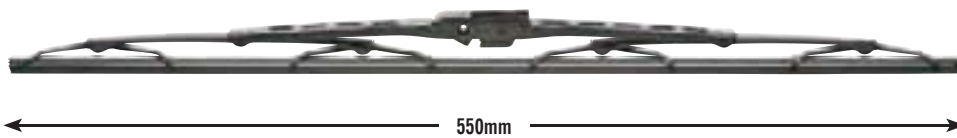

- 8x3mm 
- 9x3mm 
- 9x4mm 

EF550



- 9x3mm 
- 9x4mm 

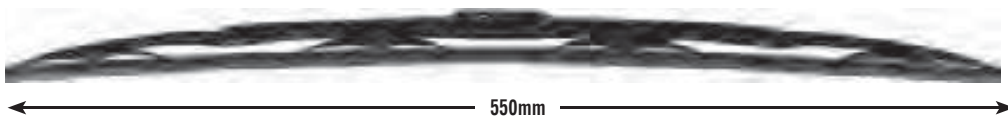

EF553



- 9x4mm Wet blade 

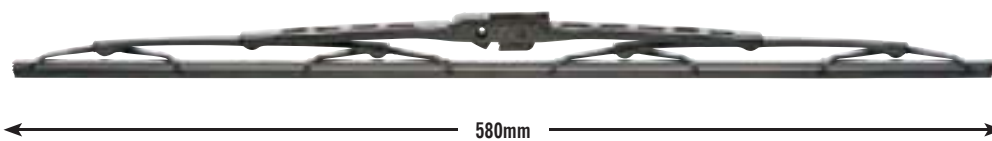

EF580

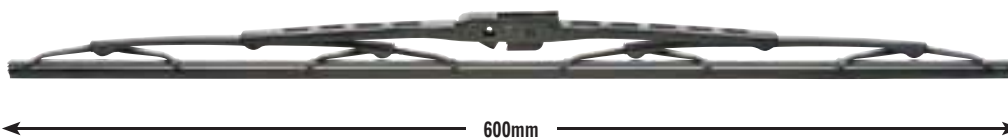

- 9x3mm 
- 9x4mm 

EF600



- 9x3mm 
- 9x4mm 



EF603

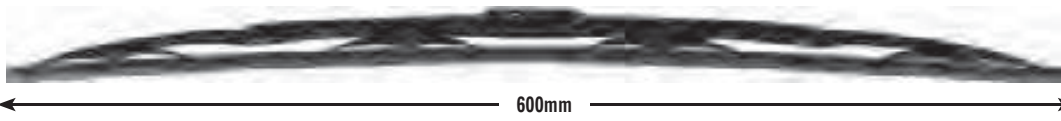

9x4mm
Wet blade



EF641

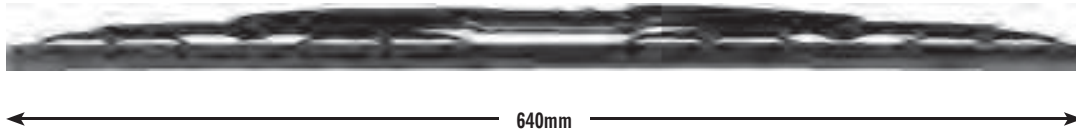

EF650



9x3mm



9x4mm



EF651

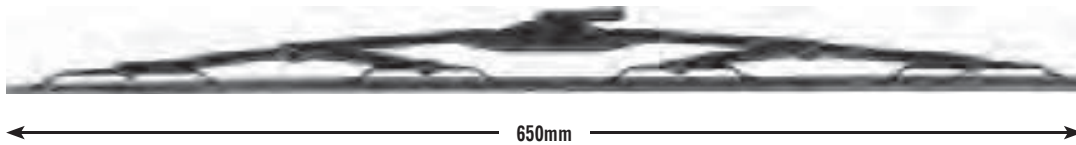

EF653

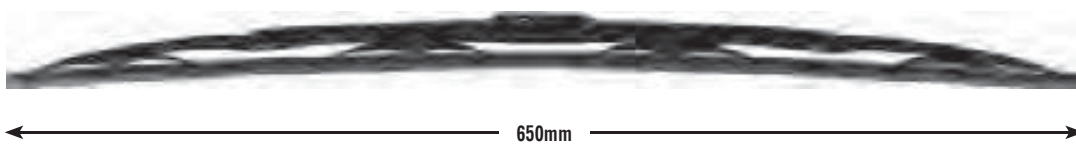

9x4mm
Wet blade



EF700

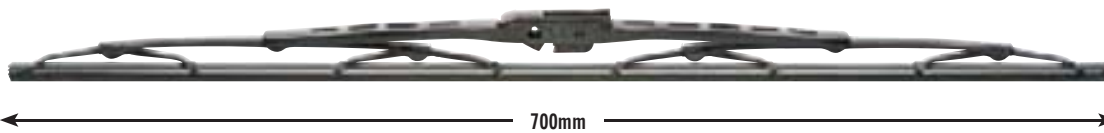

9x3mm



9x4mm



EF701

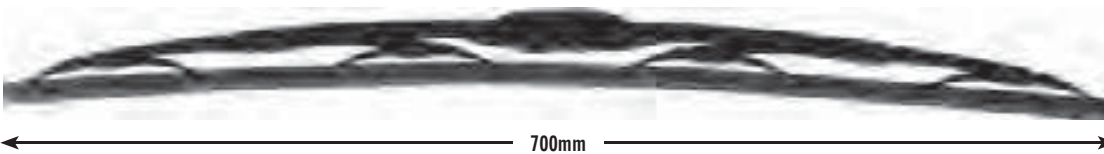

12x4mm



EF703

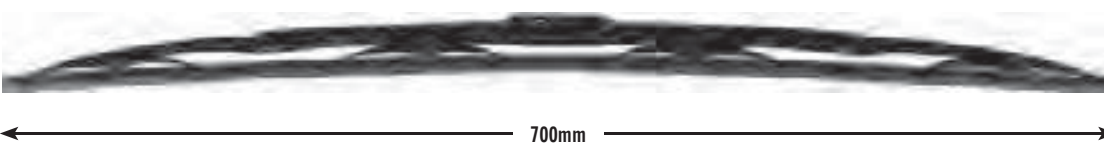

9x4mm
Wet blade





EFB3514L



EFB3518L



22mm



17mm



EFB406

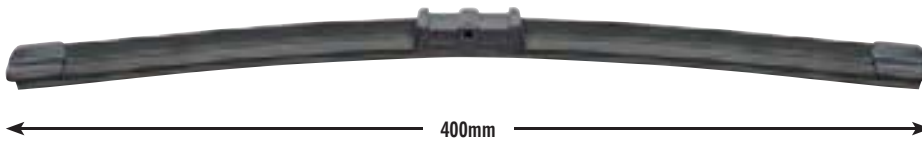

22mm

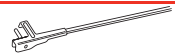

EFB4014L



EFB4017L



19mm



EFB4018L

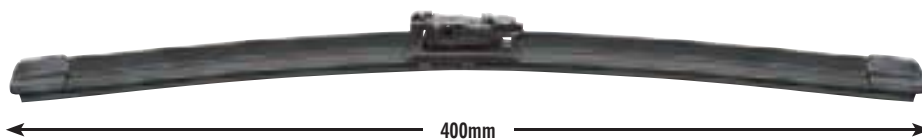

22mm



17mm

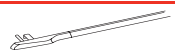

EFB436



22mm

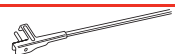

EFB4318L



22mm

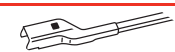

17mm

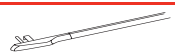



EFB456



22mm



EFB4514L



EFB4517L



19mm

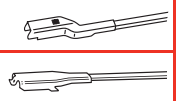

EFB4518L



22mm

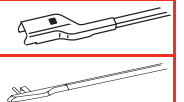

17mm

EFB486



22mm



EFB4817L



19mm

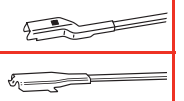

EFB4818L



22mm

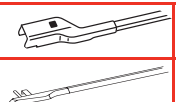

17mm

EFB506



22mm





EFB5014L



EFB5017L



19mm



EFB5018L



22mm



17mm



EFB536



22mm



EFB5317L



19mm

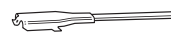

EFB5317R



19mm



EFB5318L



22mm



17mm



EFB5318R



22mm



17mm





EFB554



EFB555

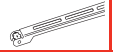
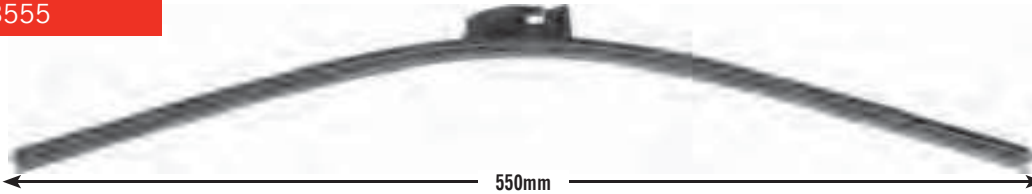

EFB556



22mm

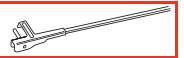

EFB5514L



EFB5514R



EFB5515

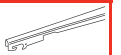
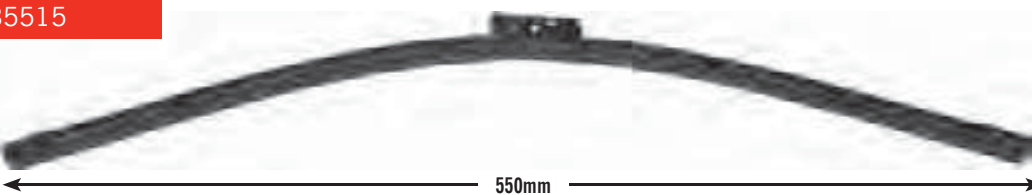

EFB5517L



19mm



EFB5517R



19mm





EFB606

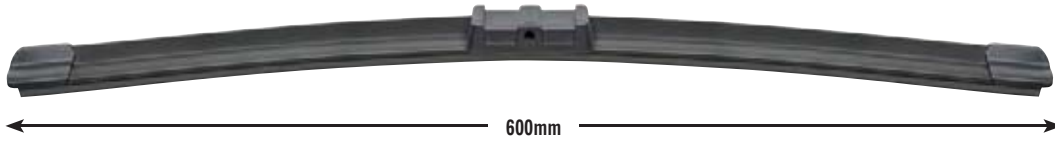

22mm



EFB6014L



EFB6017L



19mm



EFB6017R



19mm



EFB6018L



22mm



17mm



EFB6018R



22mm



17mm



EFB654



EFB656



22mm





EFB6514L



EFB6514R



EFB6515

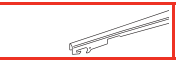
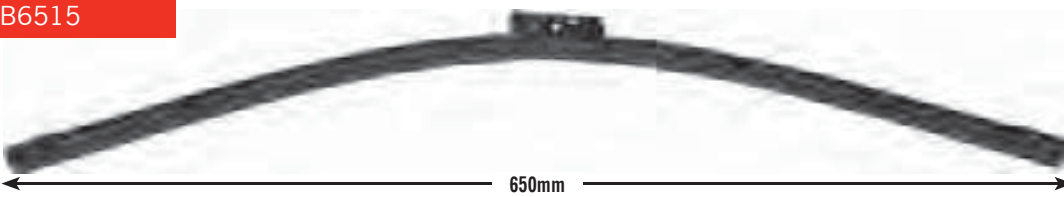

EFB6517L



19mm



EFB6517R



19mm



EFB6518L



22mm



17mm



EFB6518R



22mm



17mm



EFB706



22mm





EFB7017L



19mm

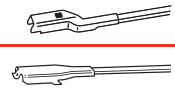

EFB7017R



19mm

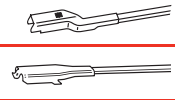

EFB7018L

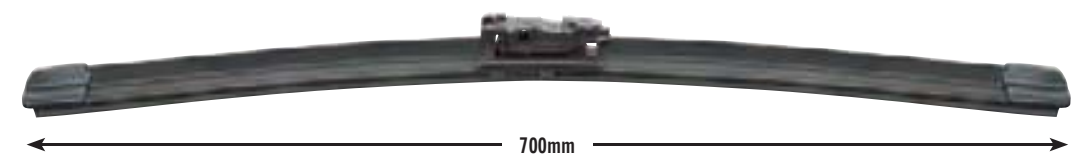

22mm

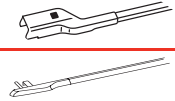

17mm

EFB7018R



22mm

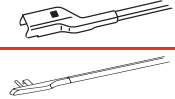

17mm

EFB7317L



19mm

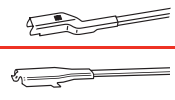

EFB7318L

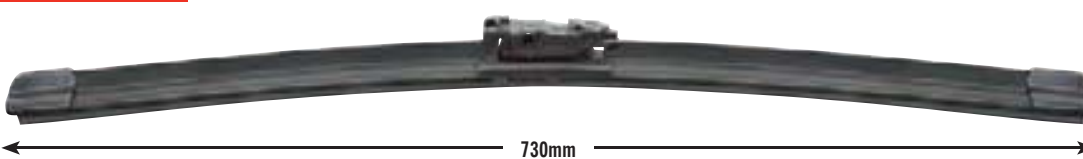

22mm

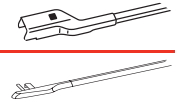

17mm

EFB7318R

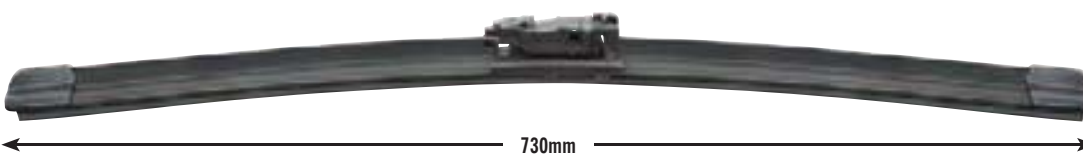

22mm

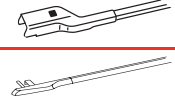

17mm

EFB756



22mm





EFB7514L



EFB7514R



EFB7518L

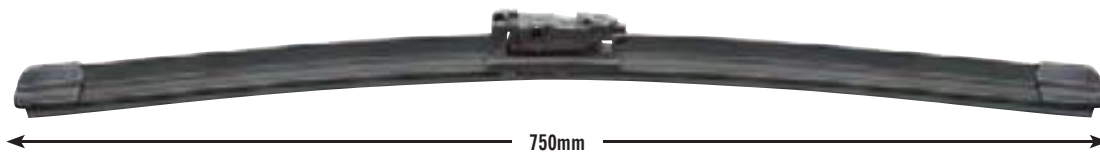

22mm



17mm



EFB7518R



22mm



17mm

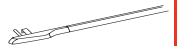

EFB806



22mm



EFB8014L



EFB8018L



22mm



17mm





EX180

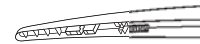
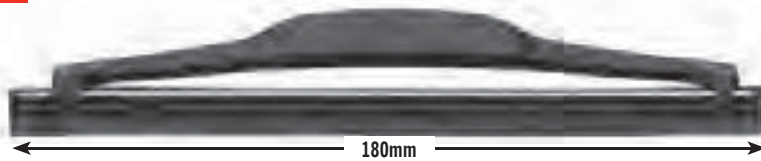

EX230

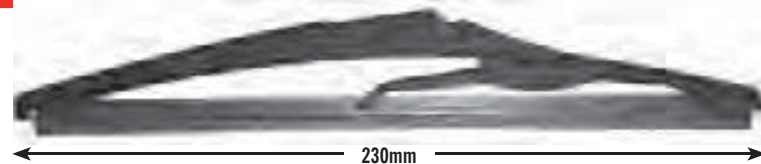

EX250

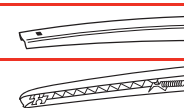
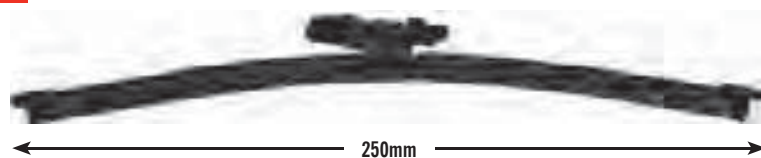

EX251

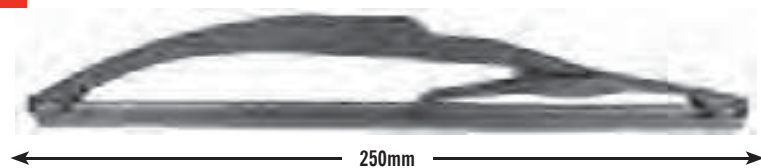

EX252

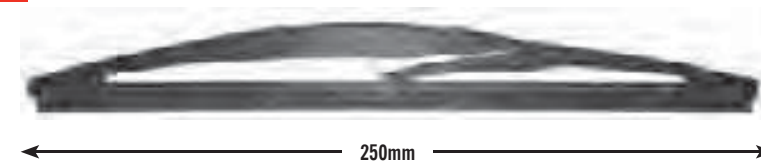

EX253

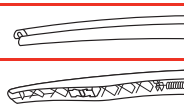
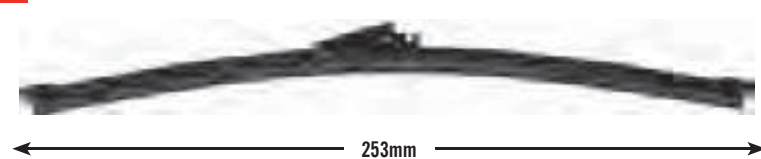

EX254

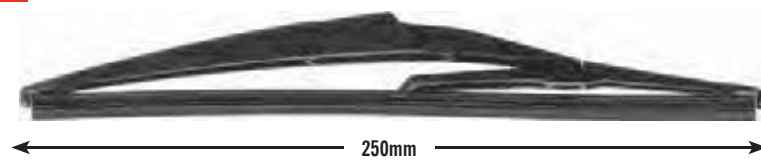

EX255

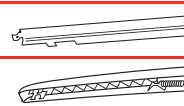
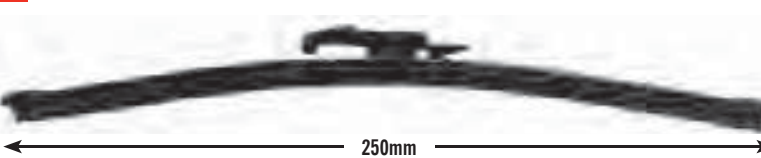



EX280

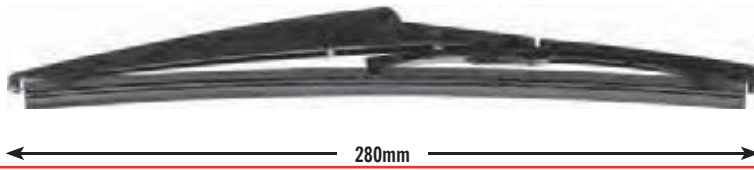

EX281

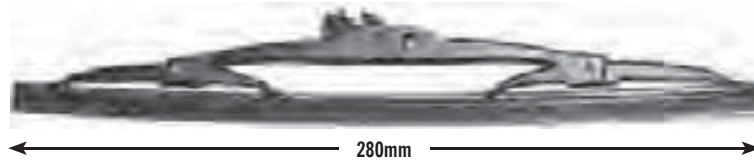

EX282

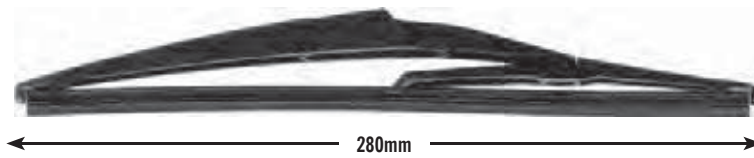

EX284

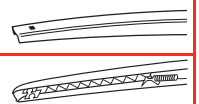
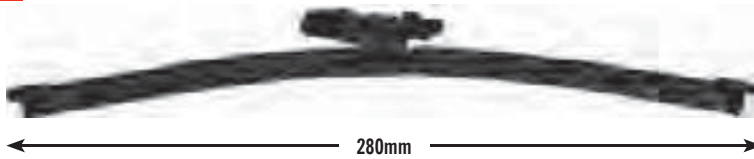

EX300

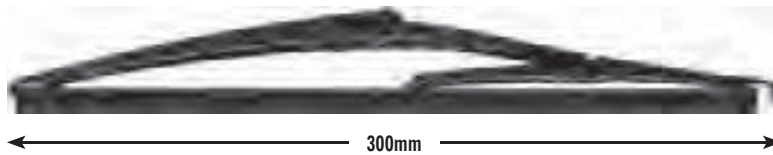

EX301

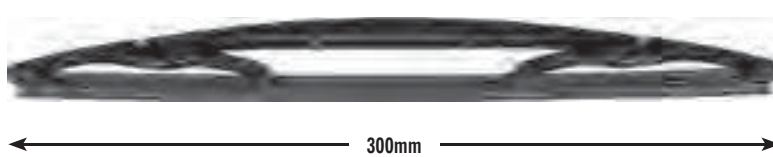

EX303

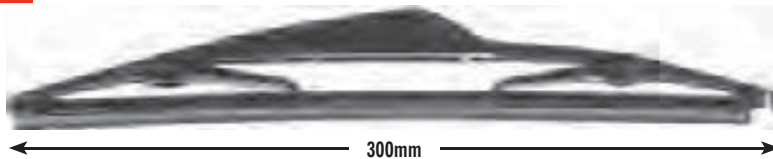

EX304

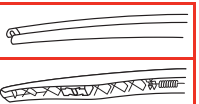
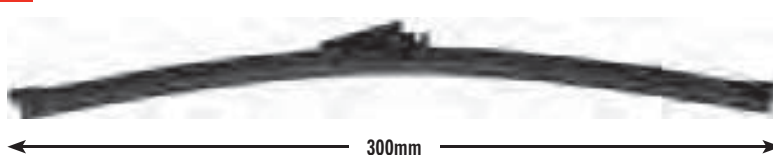



EX305

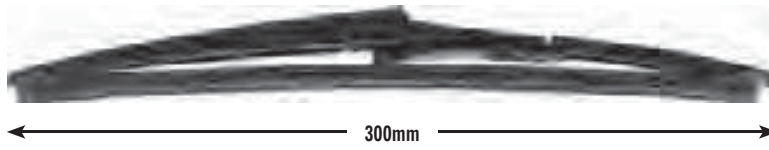

EX306

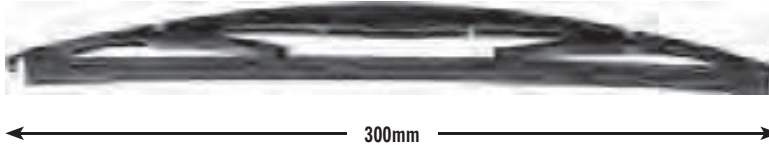

EX307

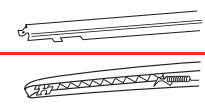
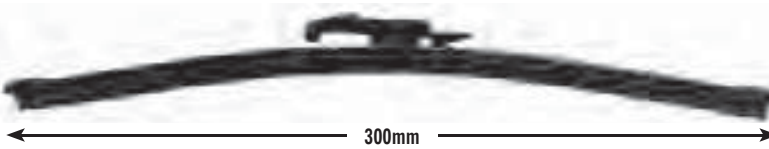

EX308

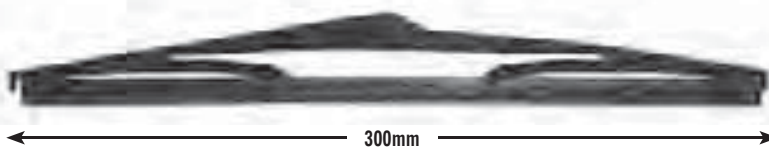

EX309

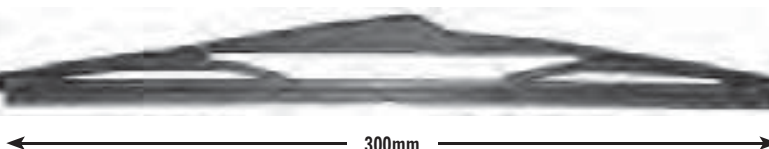

EX310

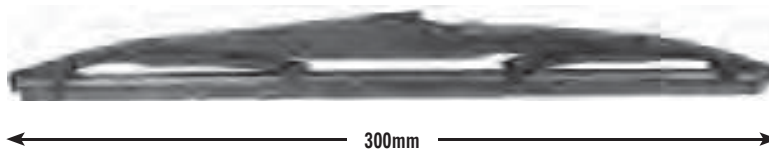

EX330

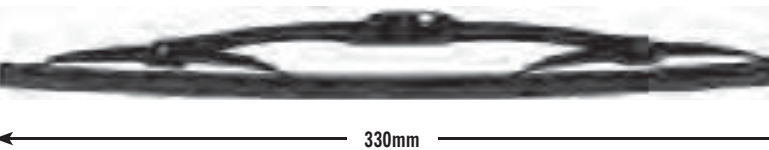

EX333

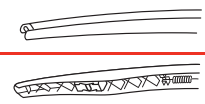
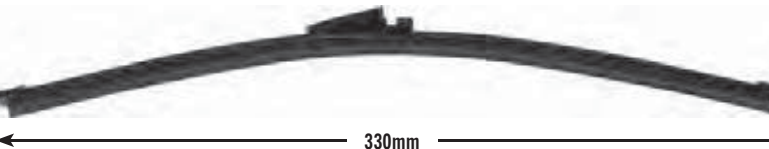



EX334

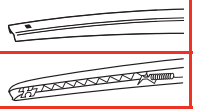
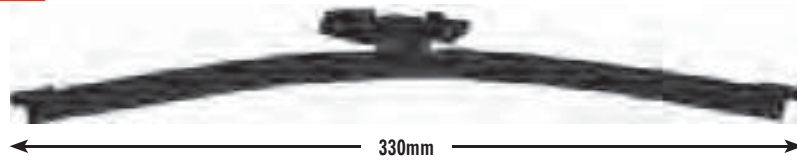

EX350

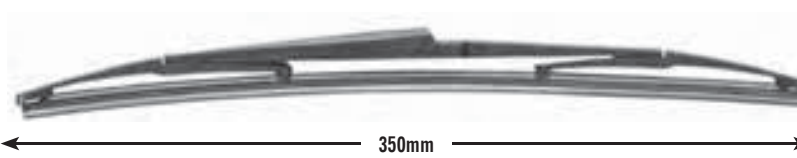

EX351

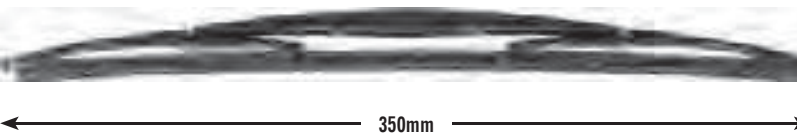

EX353

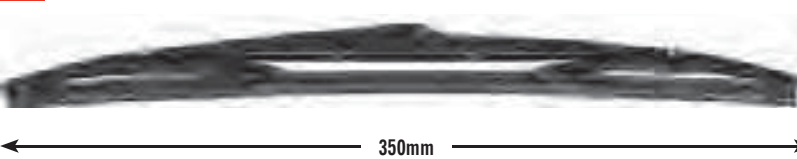

EX354

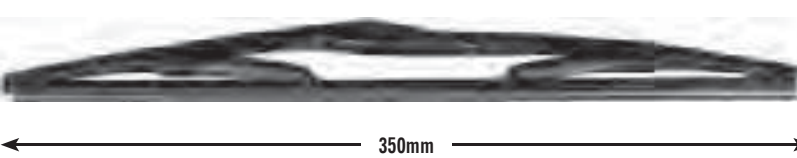

EX355

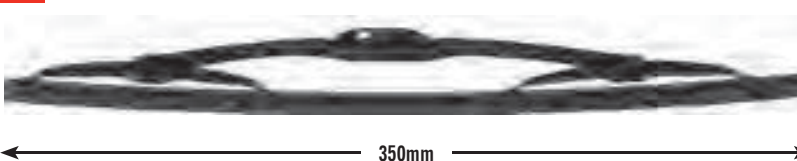

EX356

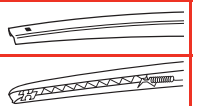
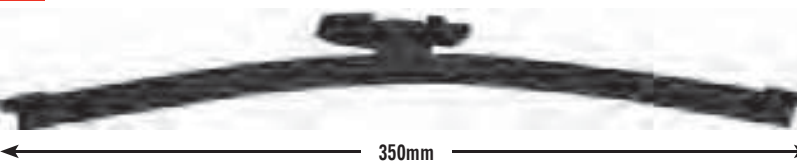

EX357

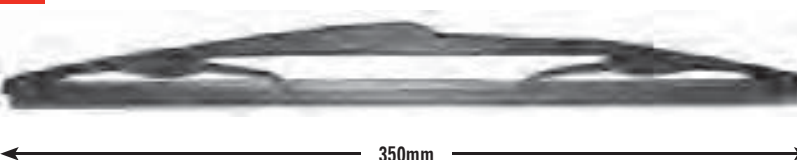



EX358

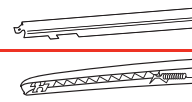
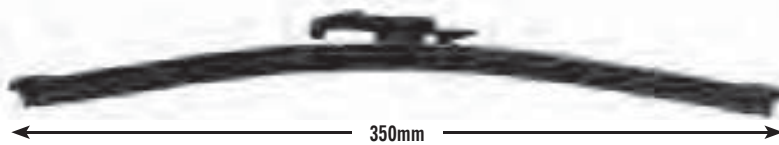

EX380

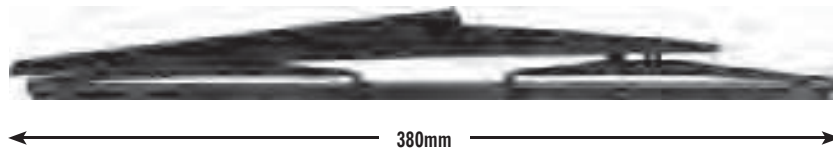

EX400

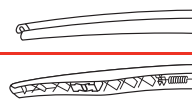
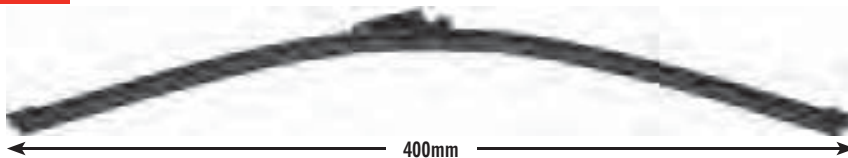

EX402

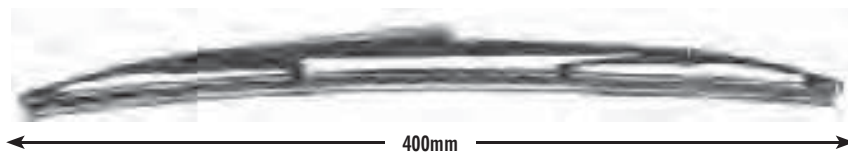

EX404

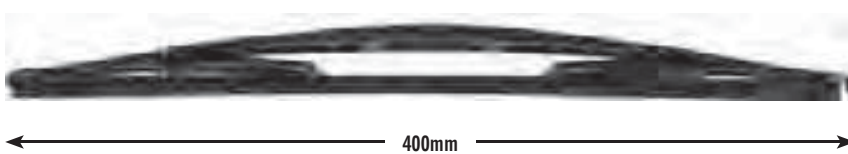

EX405

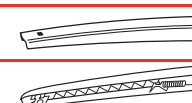
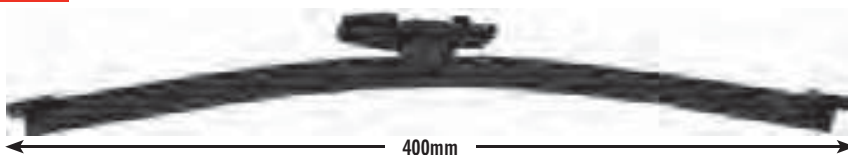

EX500

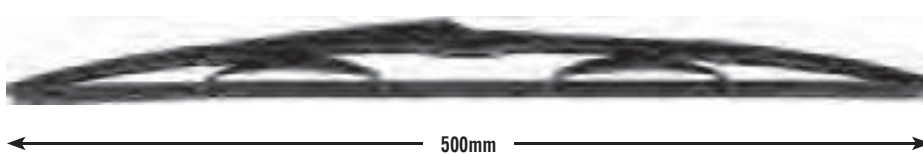



HF350



9x3mm 

9x4mm 

HF400

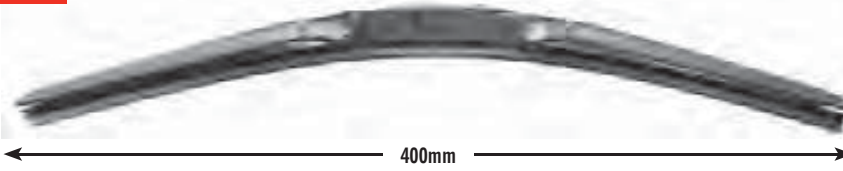

9x3mm 

9x4mm 

HF430



9x3mm 

9x4mm 

HF450

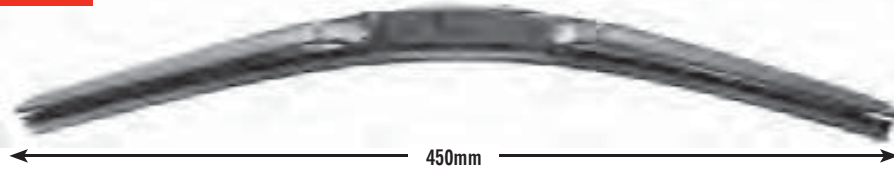

9x3mm 

9x4mm 

HF480



9x3mm 

9x4mm 

HF500



9x3mm 

9x4mm 

HF530

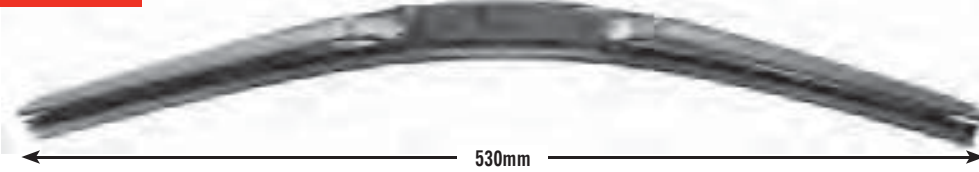

9x3mm 

9x4mm 

HF550

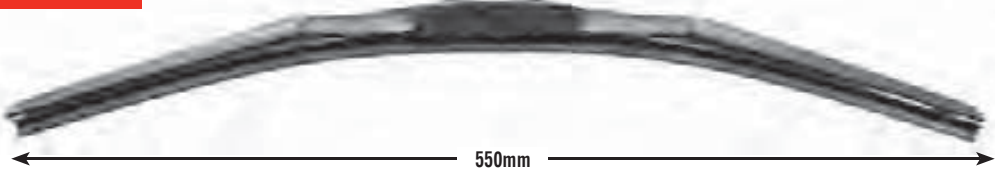

9x3mm 

9x4mm 



HF600

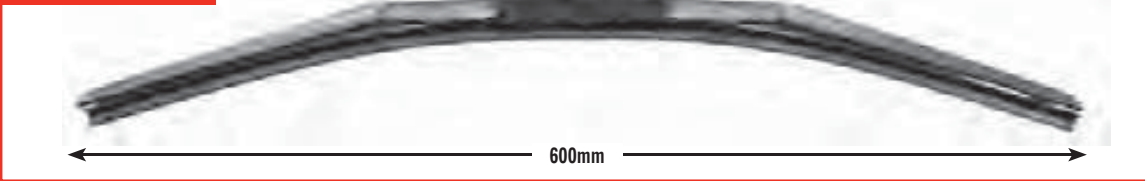

- 9x3mm
- 9x4mm

HF650



- 9x3mm
- 9x4mm

HF700

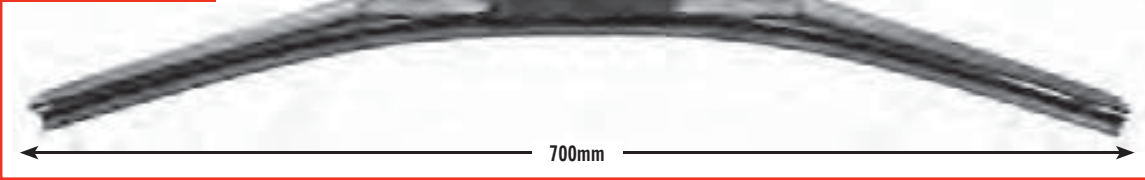

- 9x3mm
- 9x4mm



TF350L



22mm		17mm
22mm		19mm

TF400L



22mm		17mm
22mm		19mm

TF430L



22mm		17mm
22mm		19mm

TF450L



22mm		17mm
22mm		19mm

TF480L



22mm		17mm
22mm		19mm

TF500L



22mm		17mm
22mm		19mm

TF530L



22mm		17mm
22mm		19mm

TF530R



22mm		17mm
22mm		19mm



TF550L

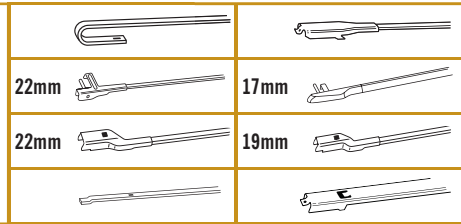

TF550R

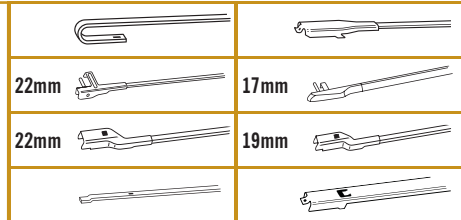

TF600L

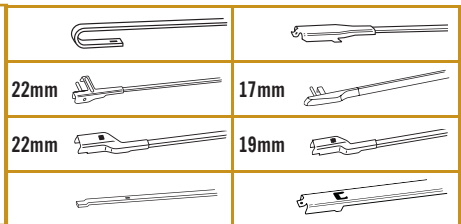

TF600R

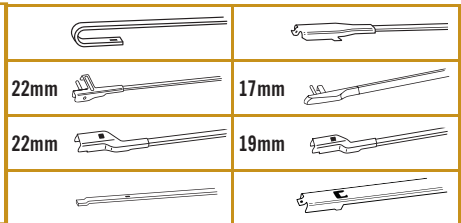

TF650L

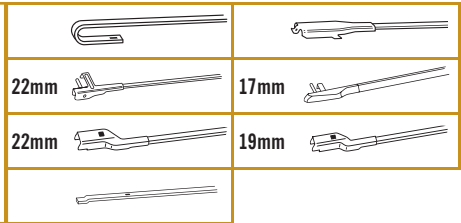

TF650R

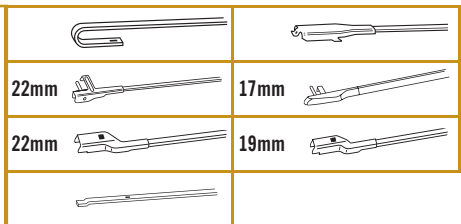

TF700L

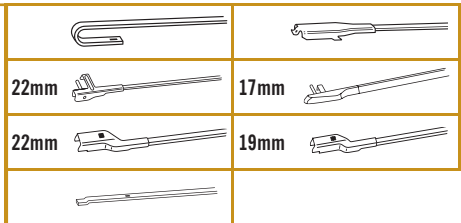

TF700R

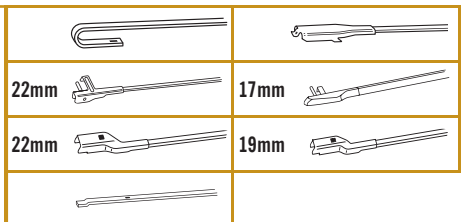



TF730L



22mm		17mm	
22mm		19mm	

TF750L



22mm		17mm	
22mm		19mm	

TF750R



22mm		17mm	
22mm		19mm	

TF800L



22mm		17mm	
22mm		19mm	



FX350

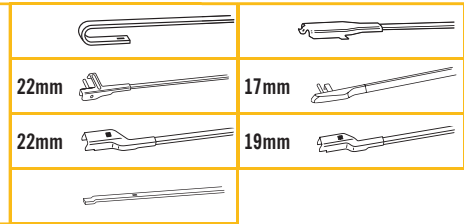
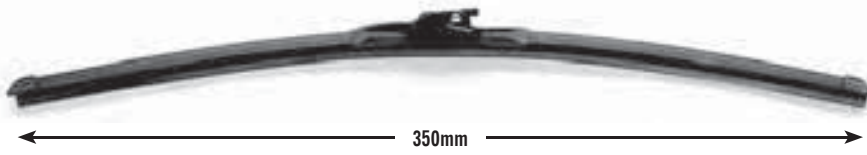

FX400

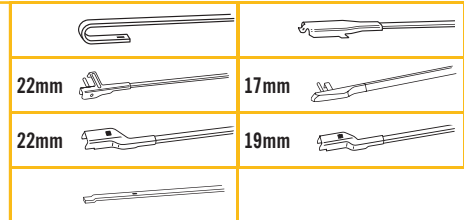
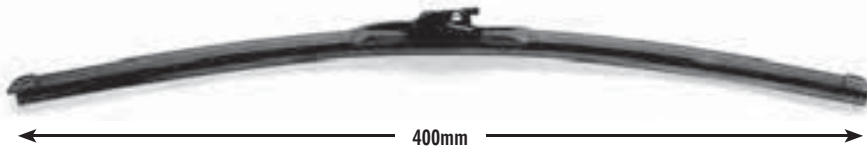

FX430

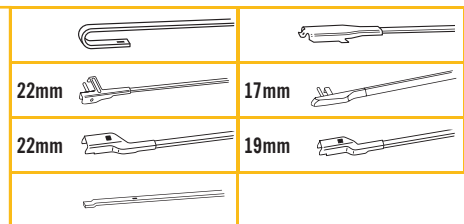
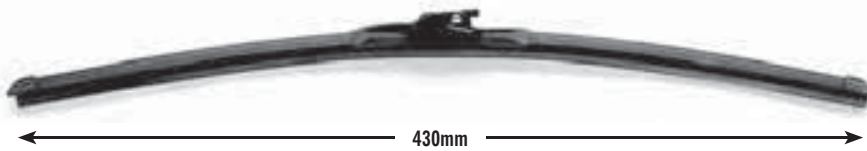

FX450

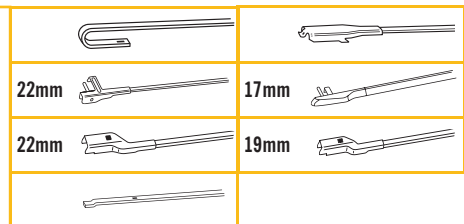
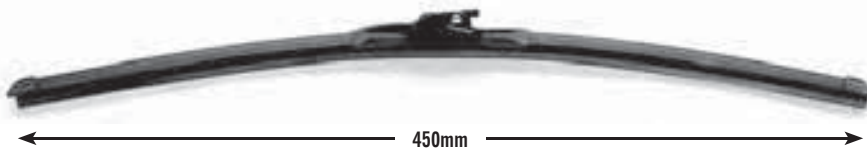

FX480

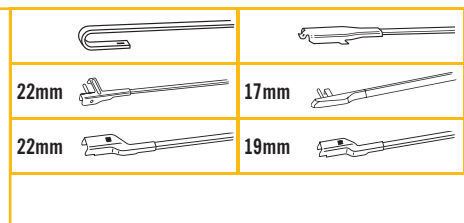
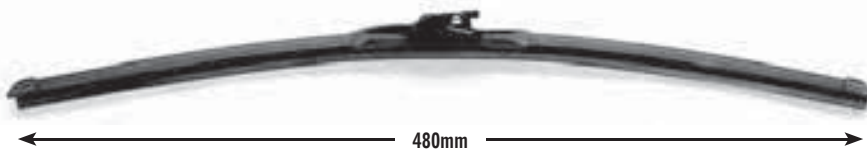

FX500

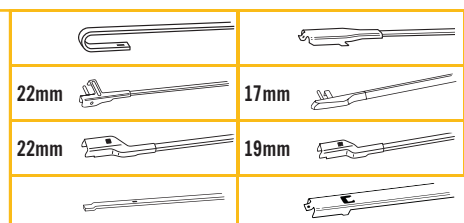
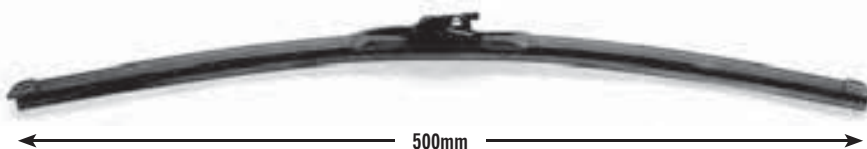

FX530

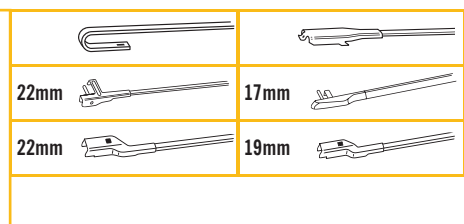
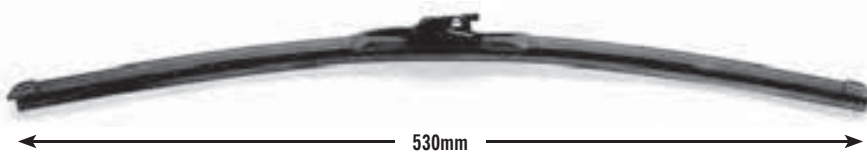

FX550

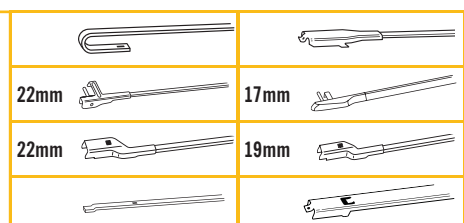
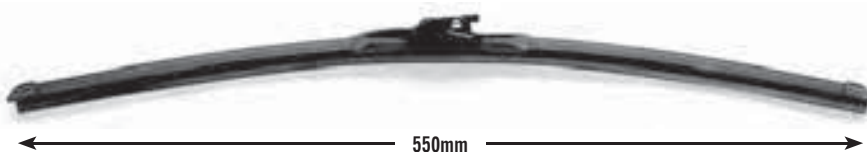



FX600

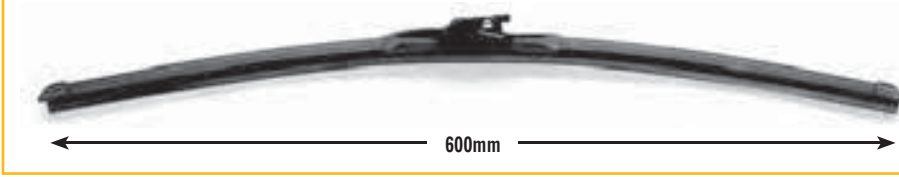

22mm		17mm
22mm		19mm

FX650

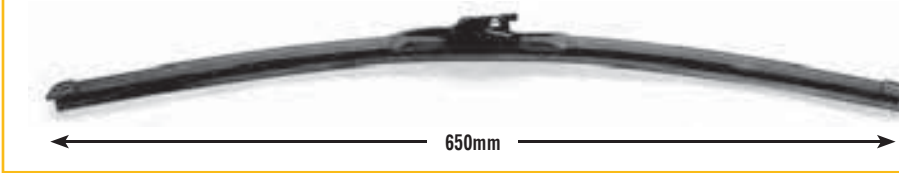

22mm		17mm
22mm		19mm

FX700

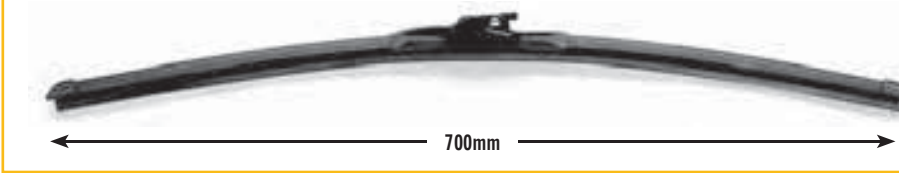

22mm		17mm
22mm		19mm

FX730



		19mm
22mm		17mm

FX750

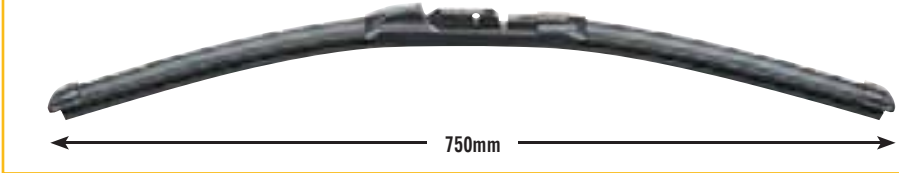



22mm		
22mm		17mm
		19mm



FX800

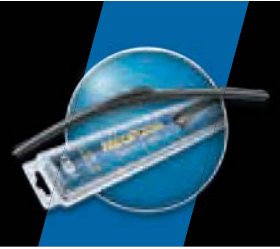

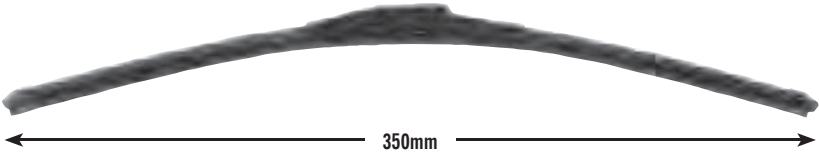

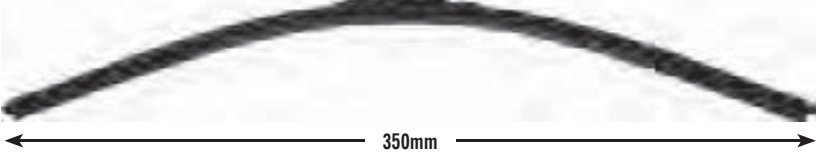

22mm		
22mm		17mm
		19mm







NF350		9x3mm 
-------	--	---

NF359		22mm 
-------	--	--

NF400		9x3mm  9x4mm 
-------	--	--

NF406		22mm 
-------	--	---

NF407		
-------	--	---

NF409		22mm 
-------	--	--

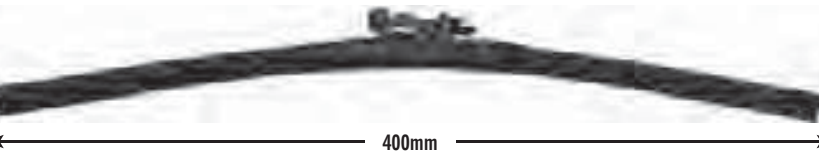
NF4013		19mm 
--------	--	--

NF4014		
--------	--	---

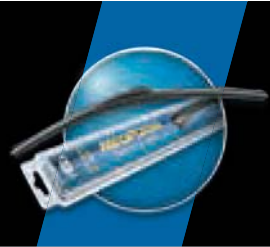

NF430

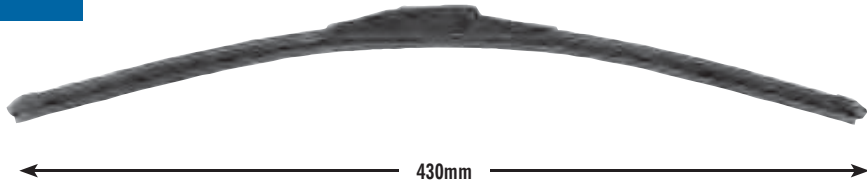

NF436

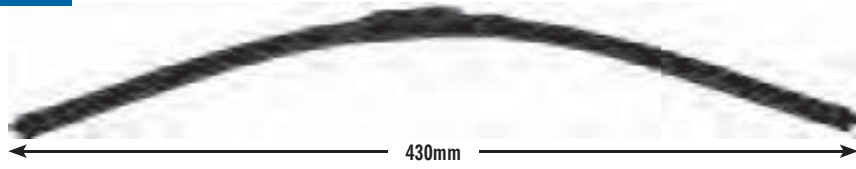

NF4316

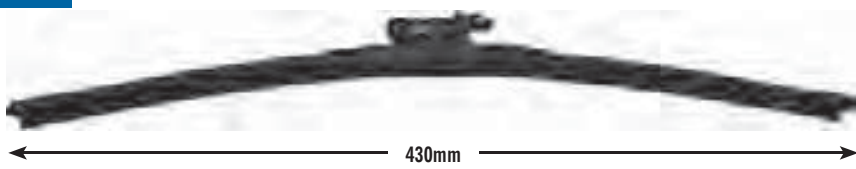

NF439

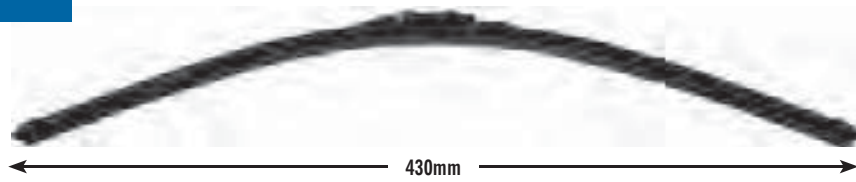

NF450



NF456

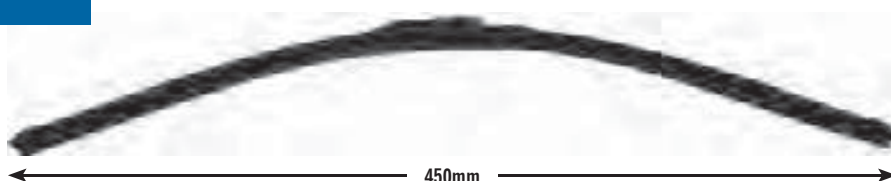

NF459

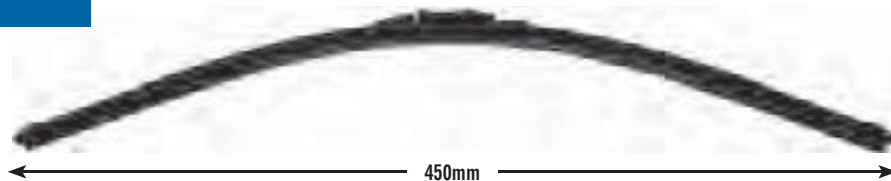

NF4513

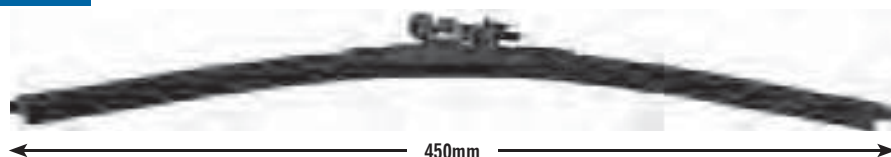

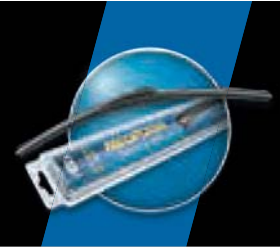

NF4514

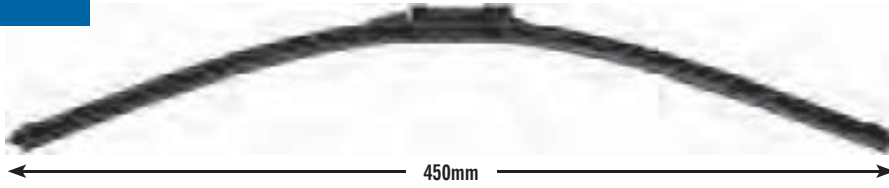

NF4516



17mm



NF480



9x3mm



9x4mm



NF486

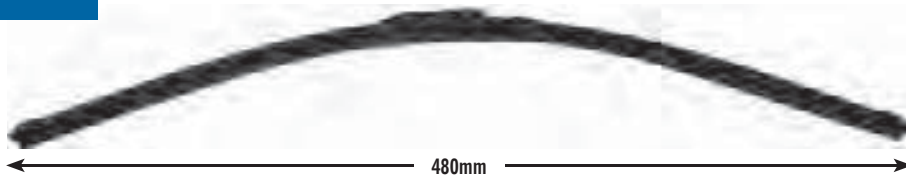

22mm



NF487



NF489

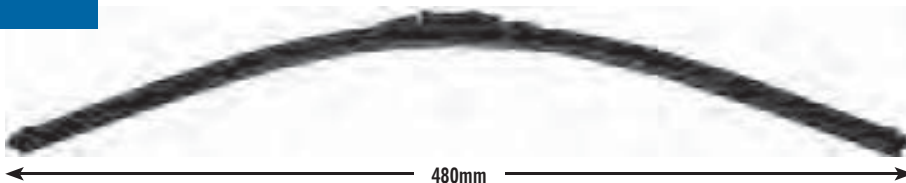

22mm



NF4813

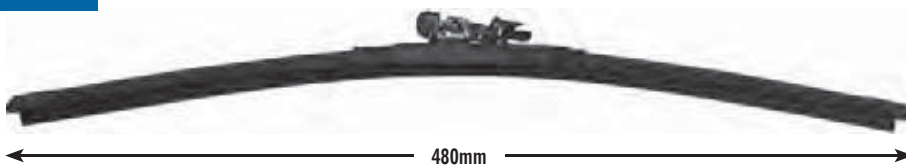

19mm



NF500



9x3mm



9x4mm



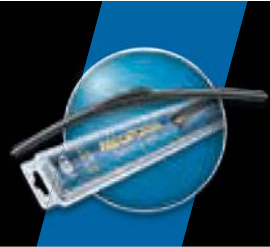

NF506		22mm
NF507		
NF509		22mm
NF5013		19mm
NF530		9x3mm 9x4mm
NF536		22mm
NF537		
NF539		22mm

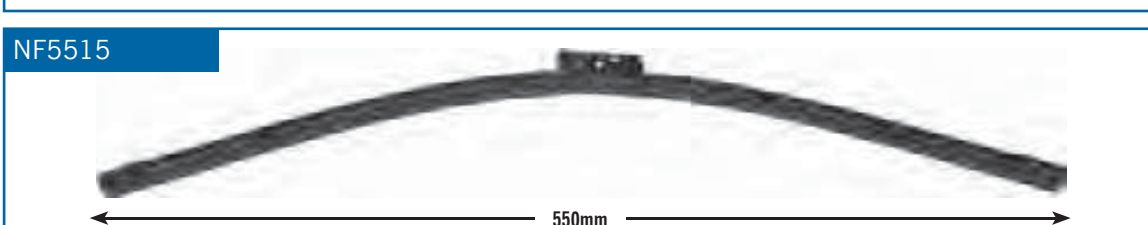
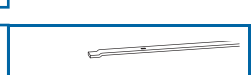
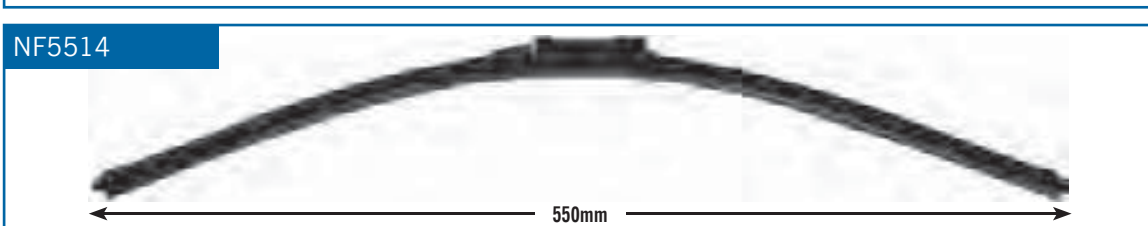
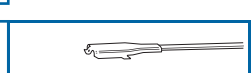
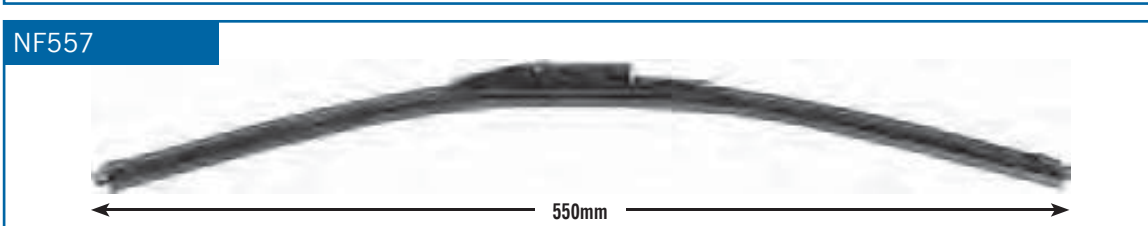
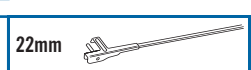
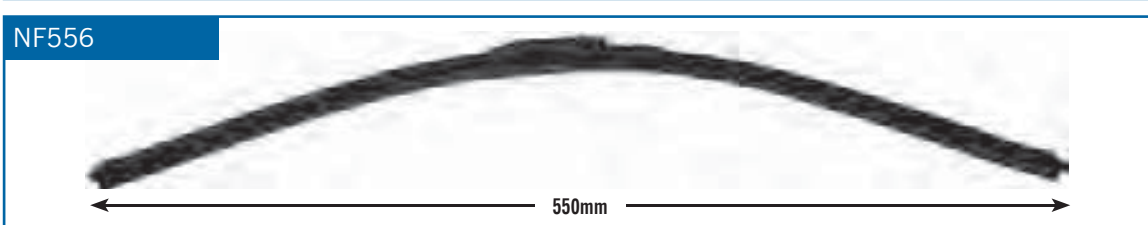
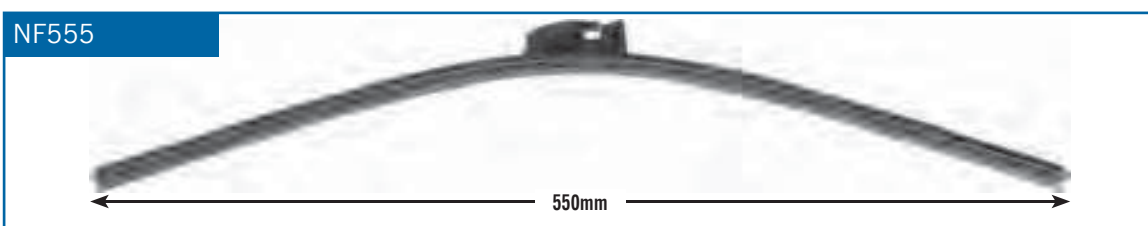
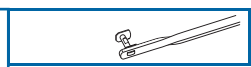
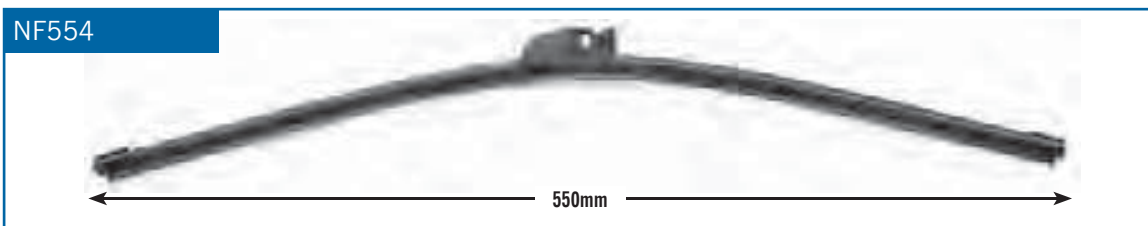
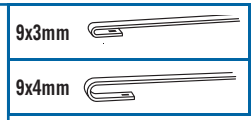
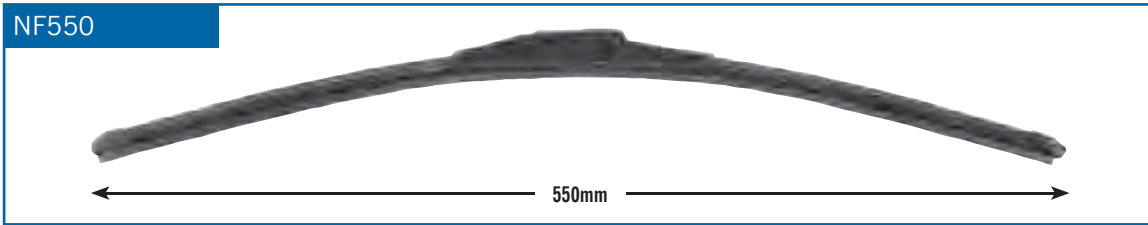
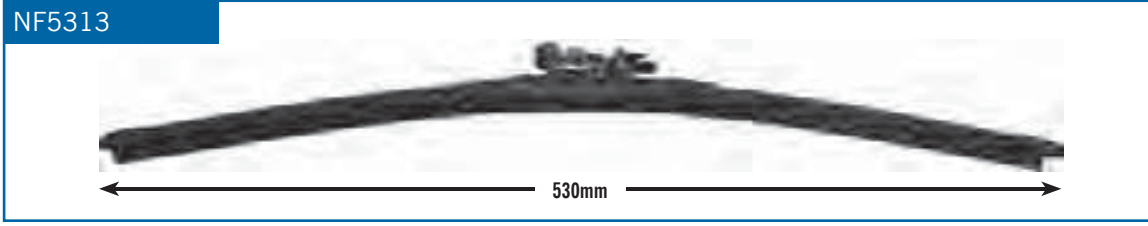
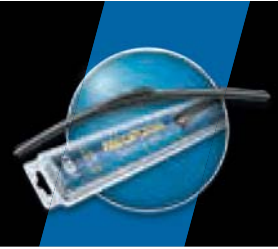

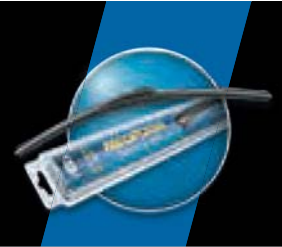

NF588

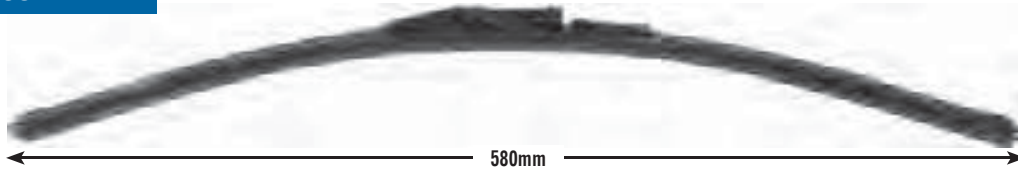

NF600



NF606

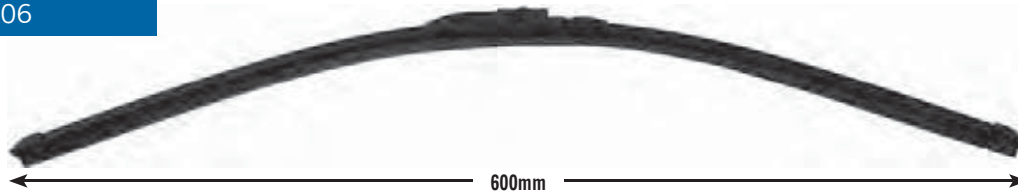

NF607

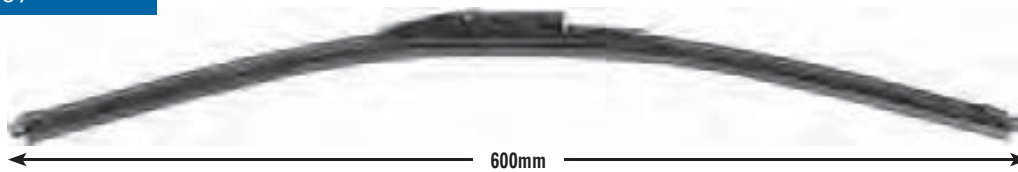

NF608

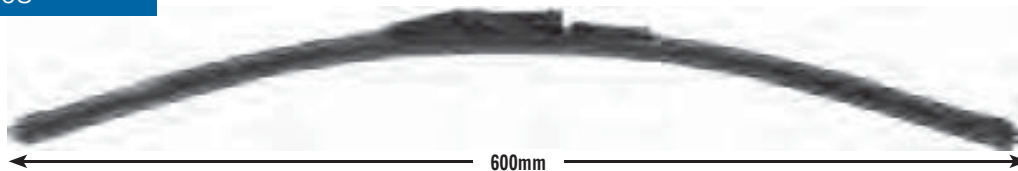

NF609

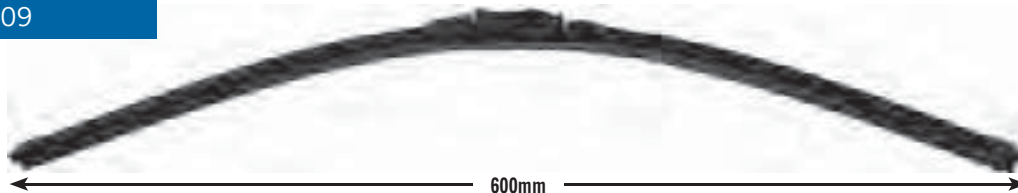

NF6013

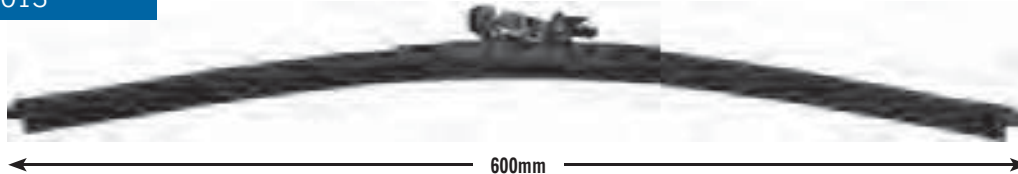

NF6014



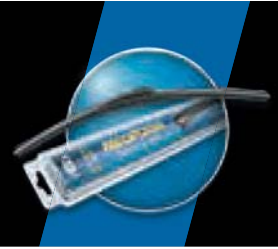

NF6016

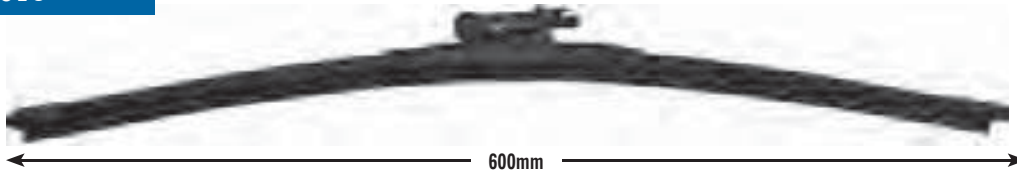

17mm



NF650



9x3mm



9x4mm



NF654

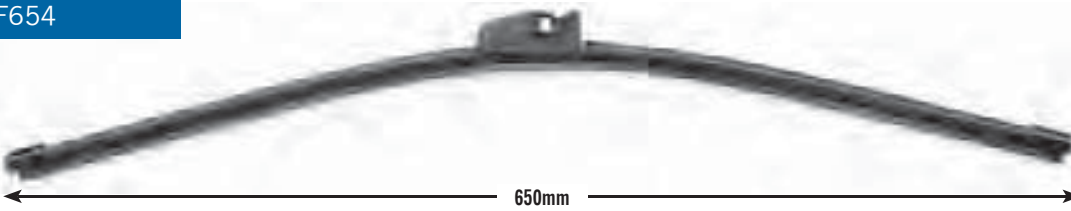

NF656

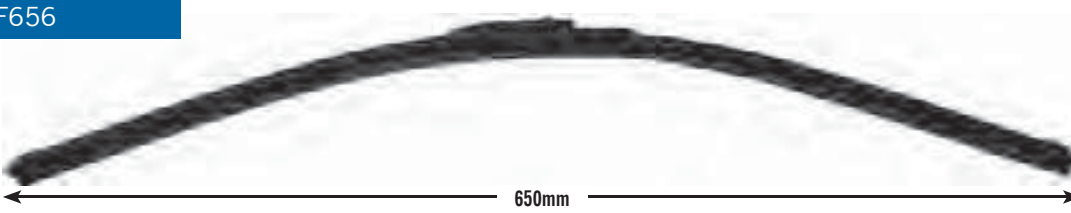

22mm



NF657

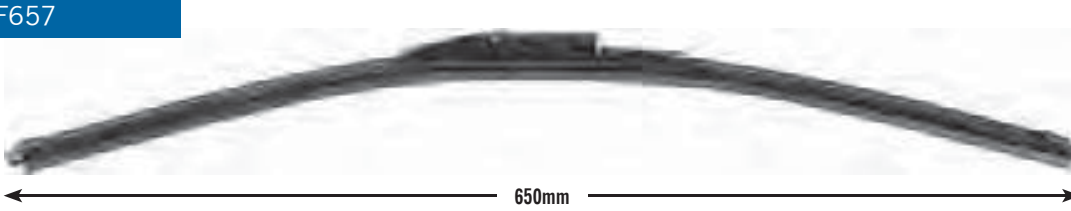

NF659

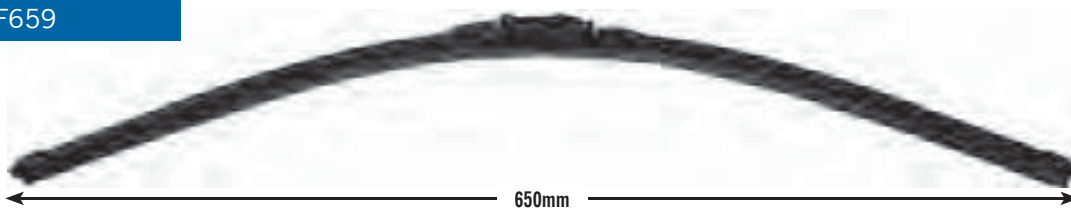

22mm



NF6513



19mm



NF6514

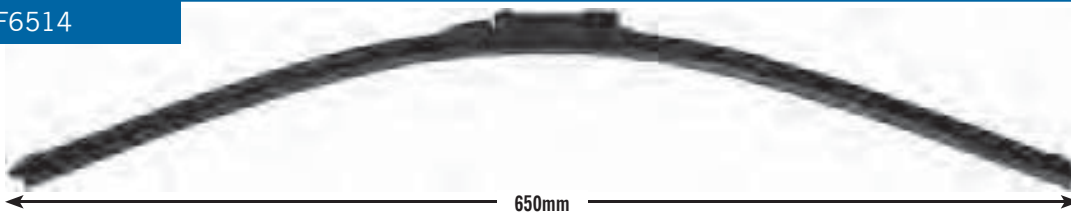

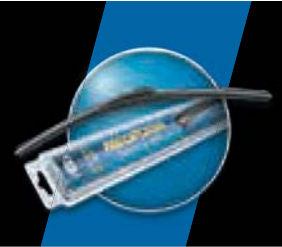

NF6515

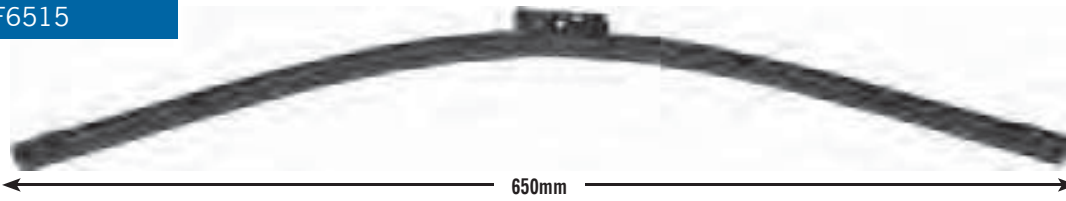

NF6516

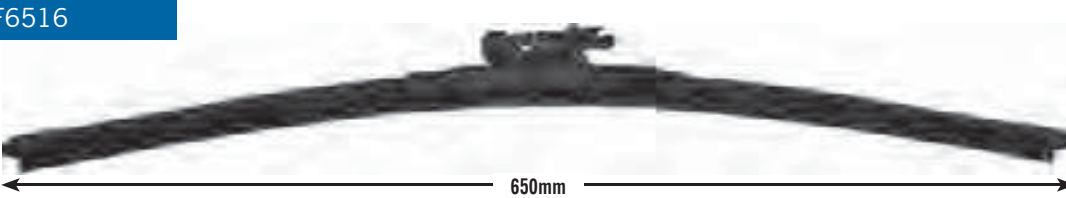

17mm



NF700

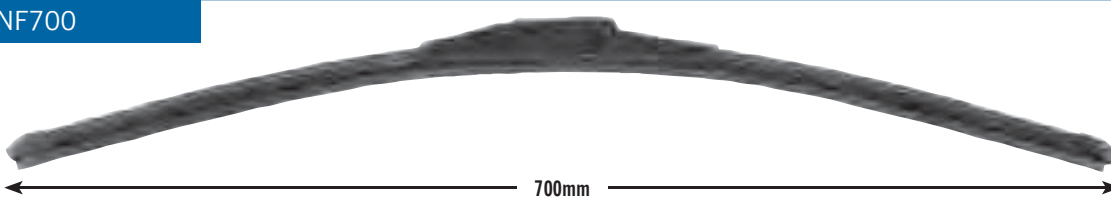

9x3mm



9x4mm



NF706

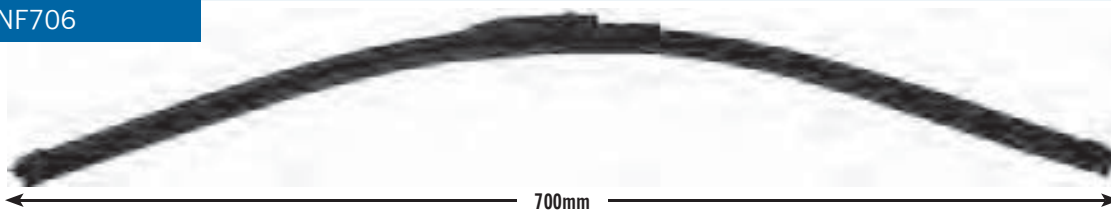

22mm



NF707

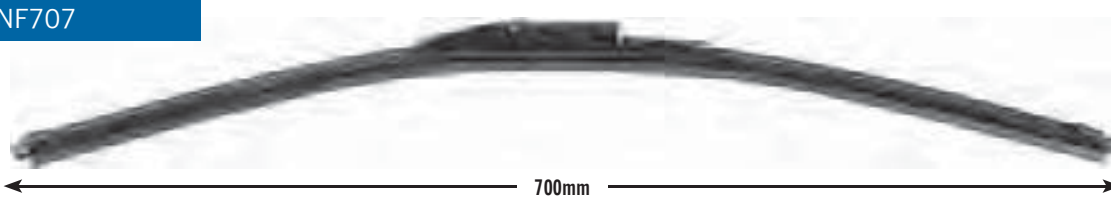

NF709

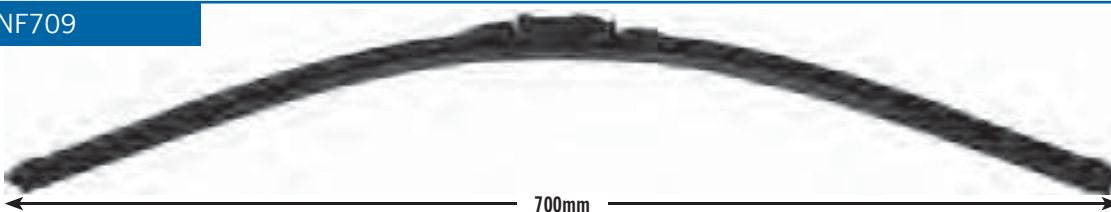

22mm



NF7013

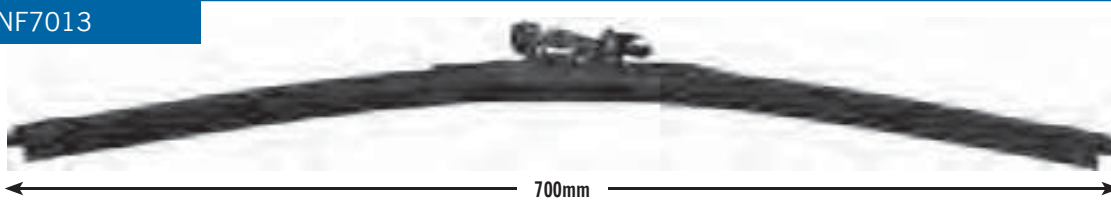

19mm



NF739

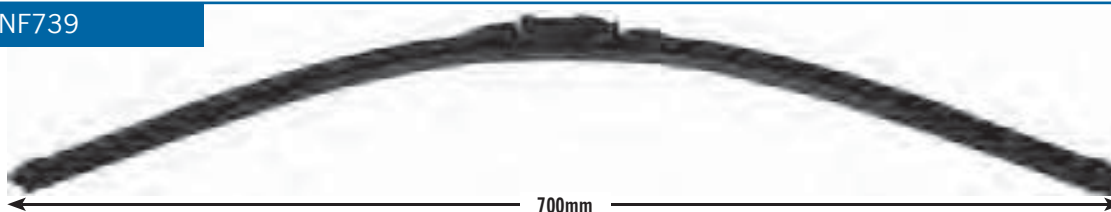

22mm



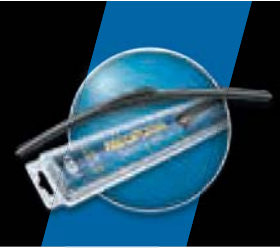

NF756

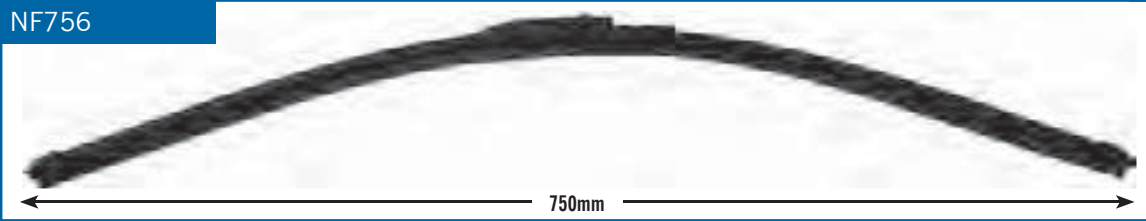

750mm

22mm 

NF759

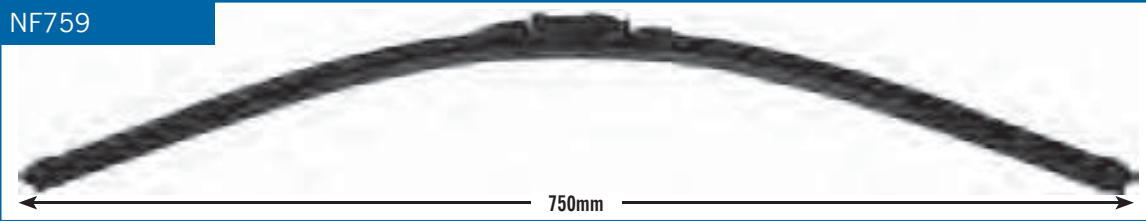

750mm

22mm 

NF7514

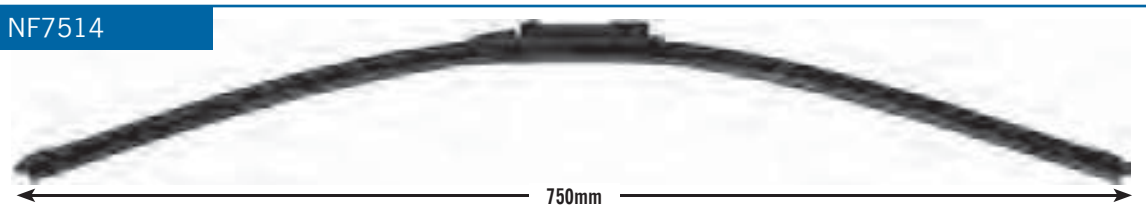

750mm



NF806

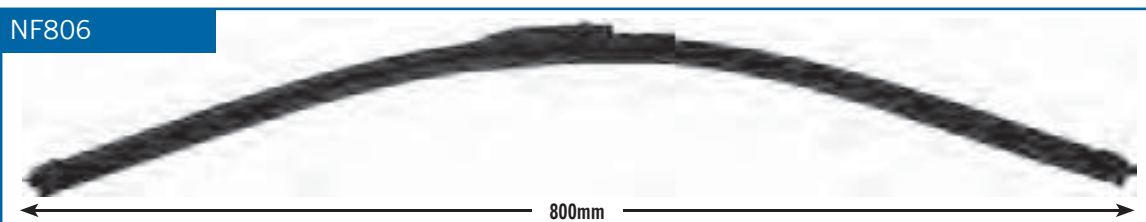

800mm

22mm 

NF809

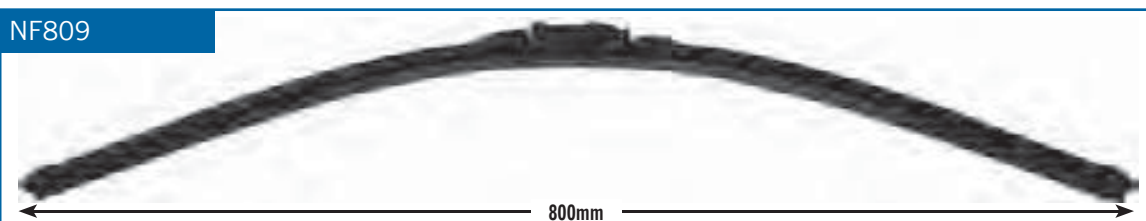

800mm

22mm 

NF8014



800mm







T280





← 280mm →

- 7x2mm 
- 9x3mm 
- 7mm 

T330





← 330mm →

- 7x2mm 
- 9x3mm 
- 7mm 

T350





← 350mm →

- 7x2mm 
- 9x3mm 
- 7mm 

T380





← 380mm →

- 9x3mm 
- 9x4mm 

T400





← 400mm →

- 9x3mm 
- 9x4mm 

T430





← 430mm →

- 9x3mm 
- 9x4mm 

T450





← 450mm →

- 9x3mm 
- 9x4mm 

T480



← 480mm →

- 9x3mm 
- 9x4mm 



T500

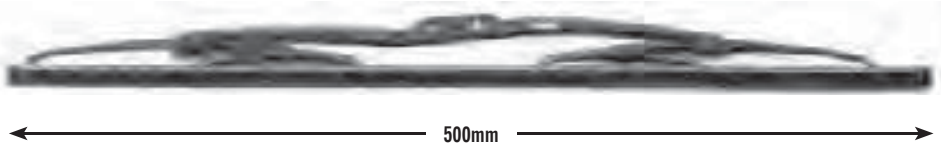

9x3mm 

9x4mm 

T530

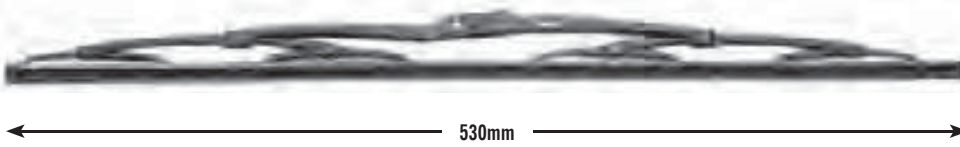

9x3mm 

9x4mm 

T550

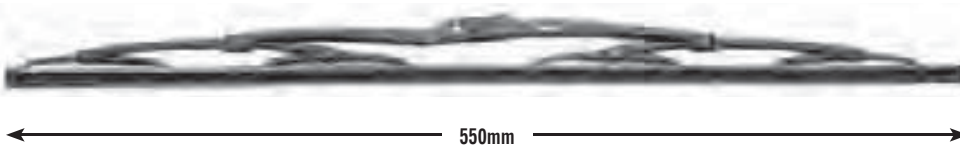

9x3mm 

9x4mm 

T580

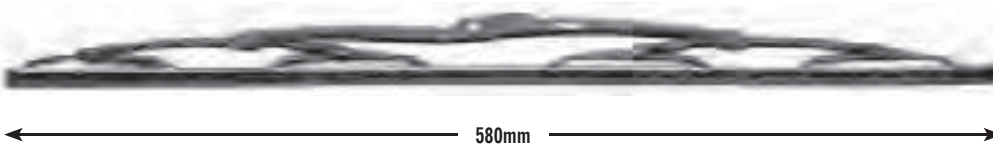

9x3mm 

9x4mm 

T600

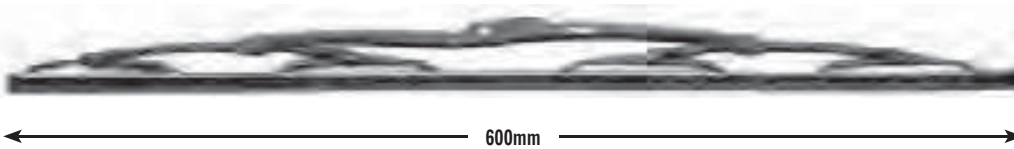

9x3mm 

9x4mm 

T650

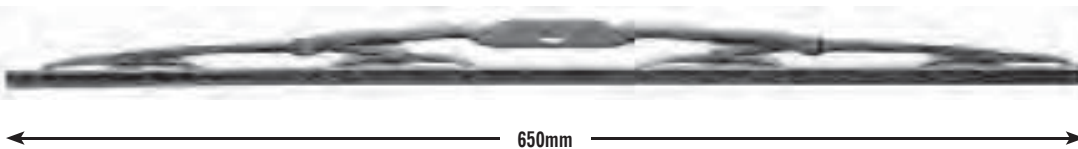

9x3mm 

9x4mm 

T700

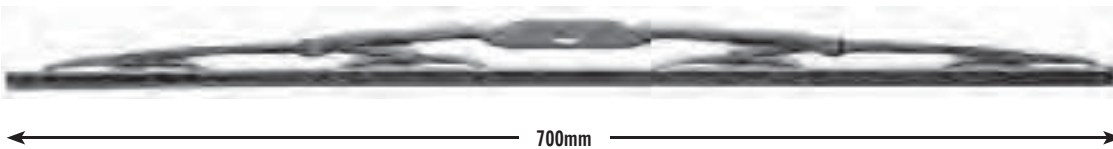

9x3mm 

9x4mm 



EF280, EF330, EF350,
EF380

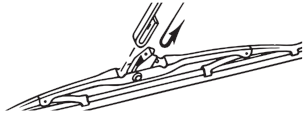

EF400, EF430, EF450, EF480,
EF500, EF530, EF550, EF580,
EF600, EF650, EF700

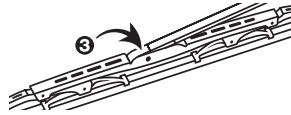
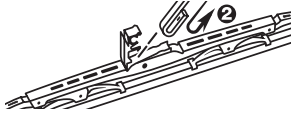
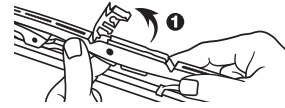

EF**3

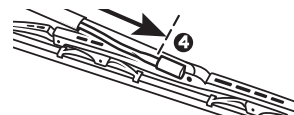
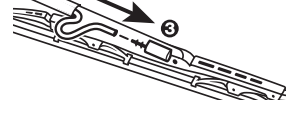
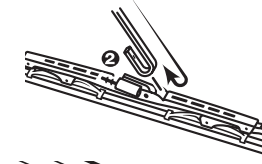
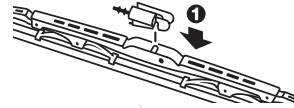

HF***

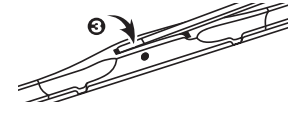
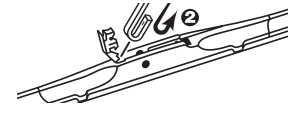
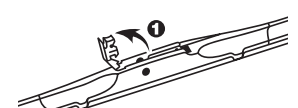

EF521, EF641

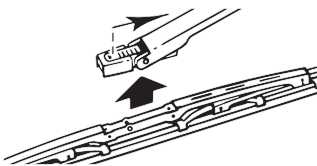

EF651

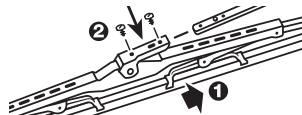

EFB**4

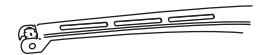
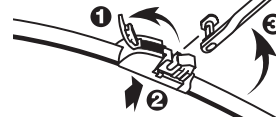

EFB**5

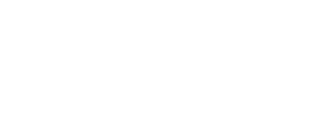
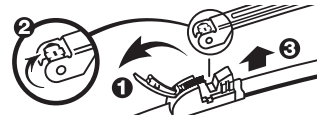

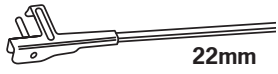

EFB** 6

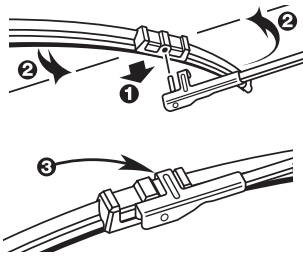

EFB** 14L/R

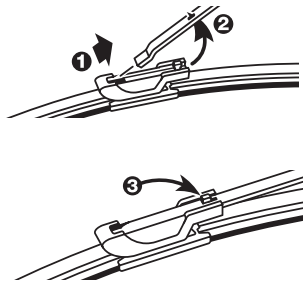

EFB** 15

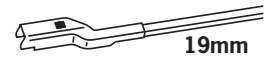
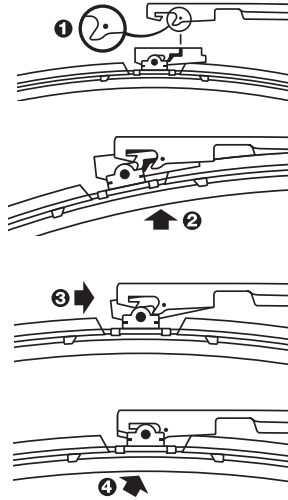

EFB** 17L/R

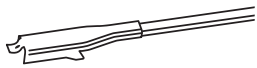
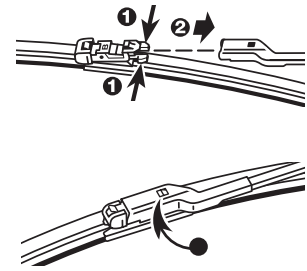

EFB** 17L/R

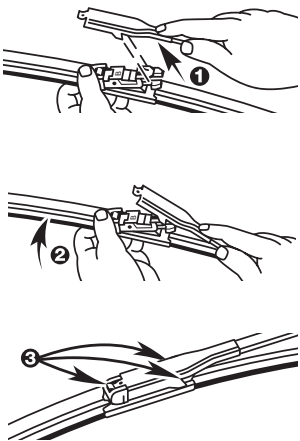

EFB** 17L/R

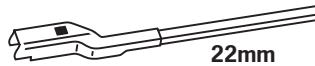
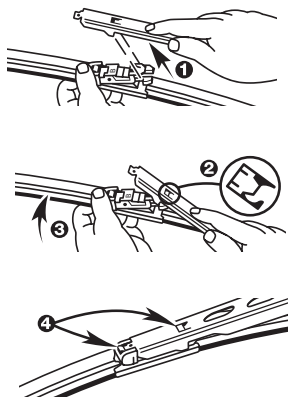

EFB** 18L/R

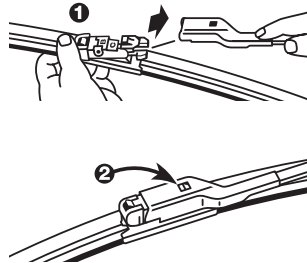

EFB** 18L/R

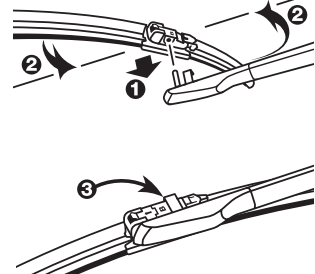





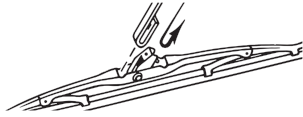

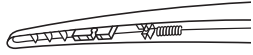
EX282

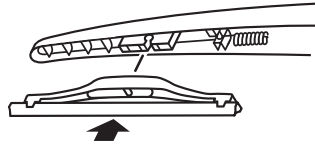



EX180

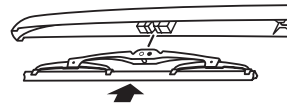



EX330

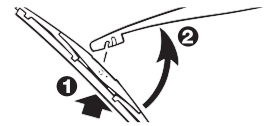



EX252, EX306, EX351

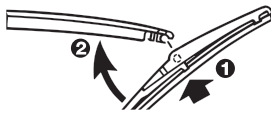



EX280, EX305, EX310,
EX350, EX402

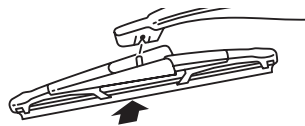



EX230, EX254, EX282,
EX300, EX303, EX308,
EX380

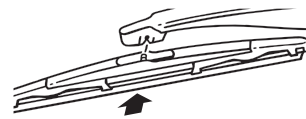

EX251, EX353, EX354,
EX357, EX500



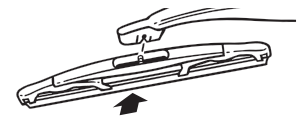

EX301, EX404



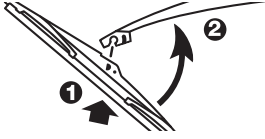

EX309



**EX253, EX304, EX333,
EX400**

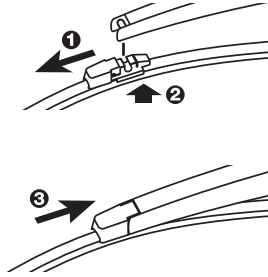

**EX253, EX304, EX333,
EX400**

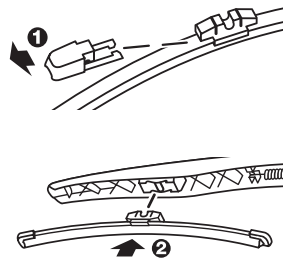

**EX250, EX284, EX334,
EX356, EX405**

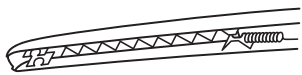
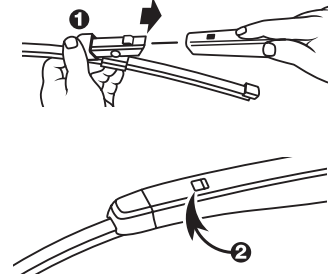

**EX250, EX284, EX334,
EX356, EX405**

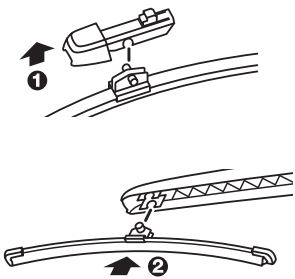

EX255, EX307, EX358

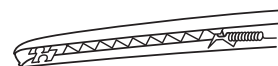
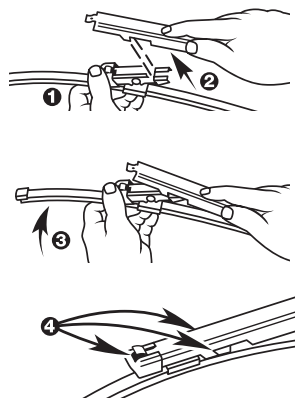

EX255, EX307, EX358

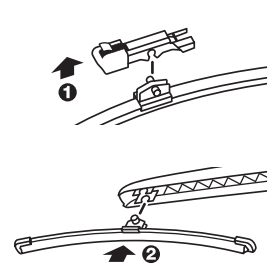

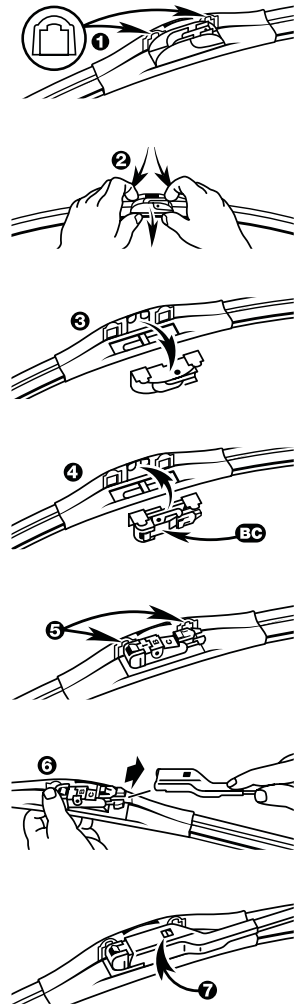
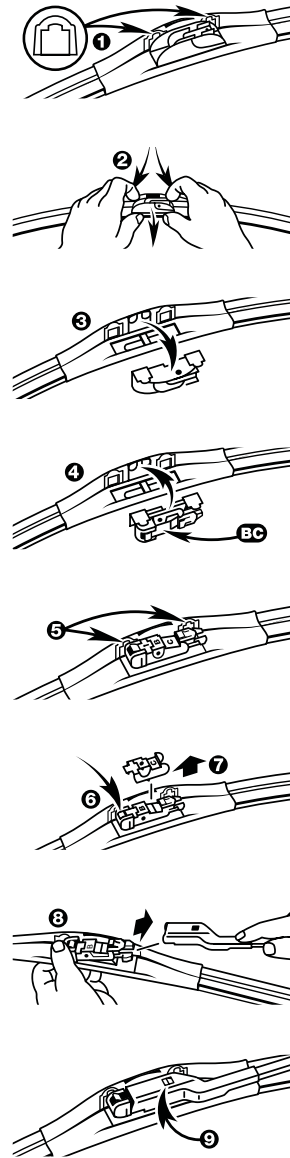
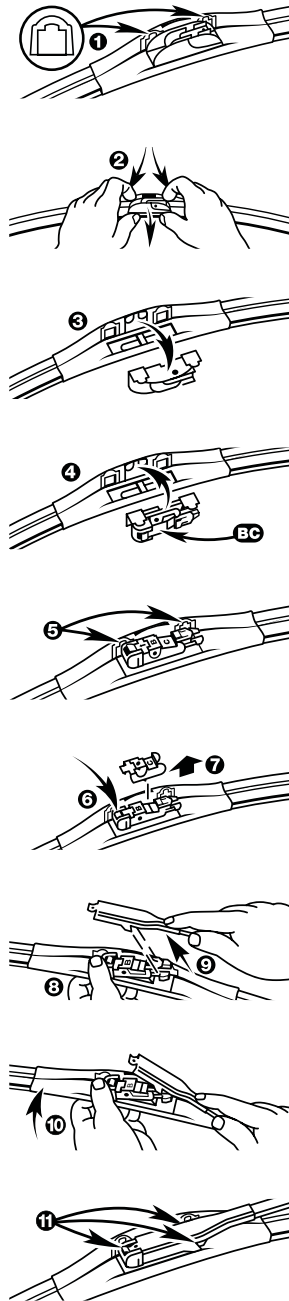
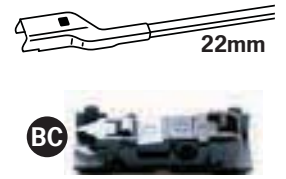
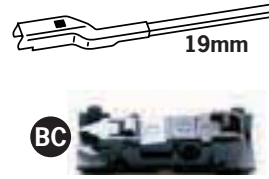
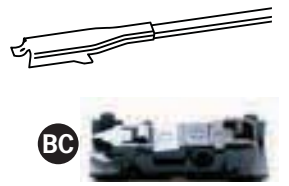
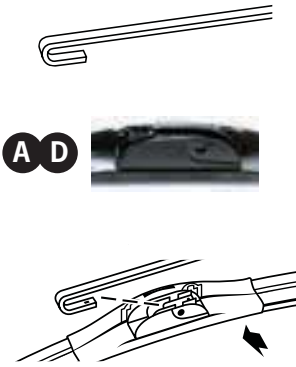

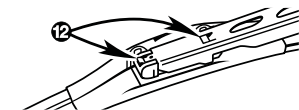
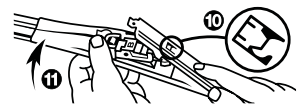
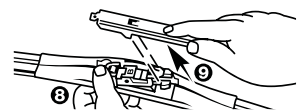
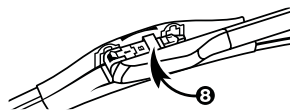
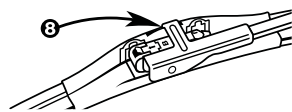
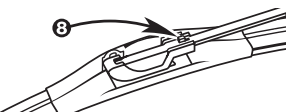
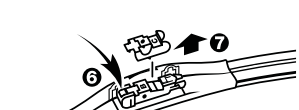
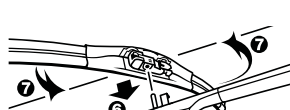
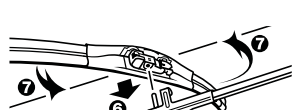
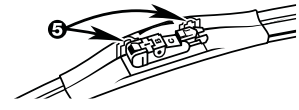
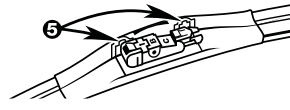
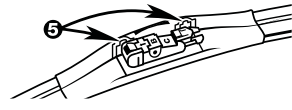
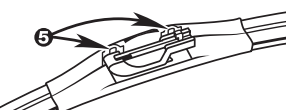
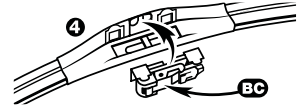
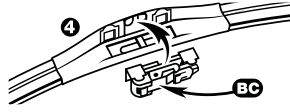
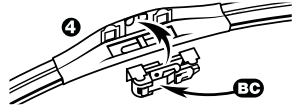
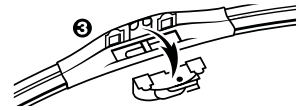
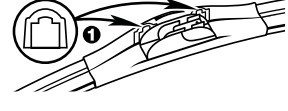
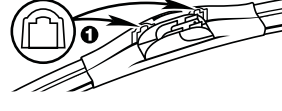
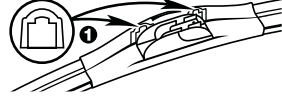
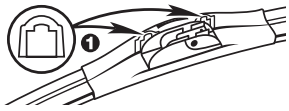
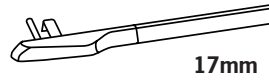
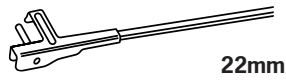

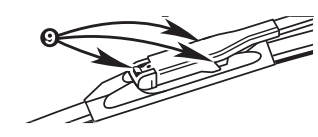
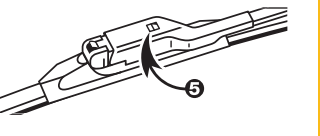
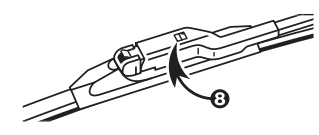
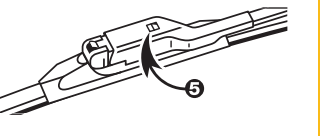
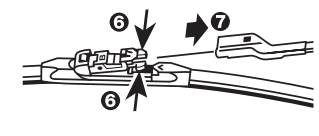
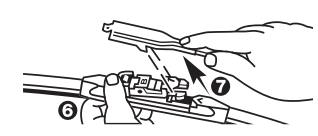
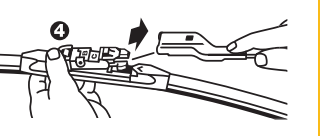
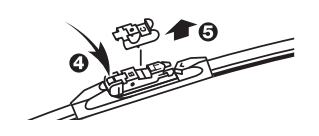
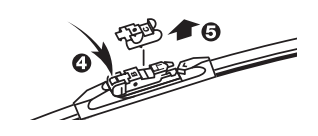
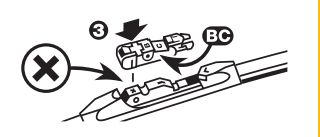
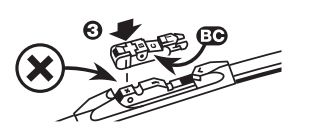
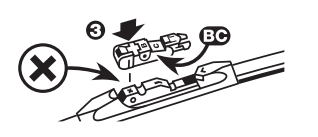
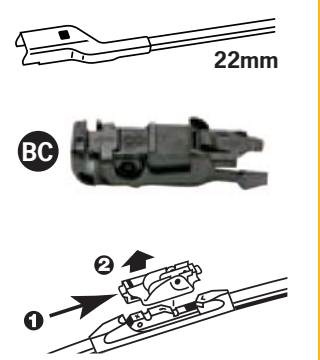
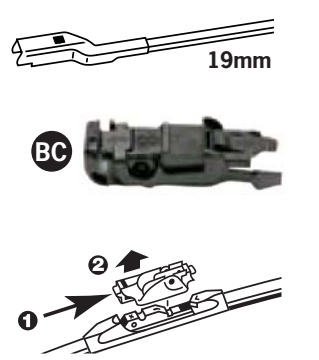
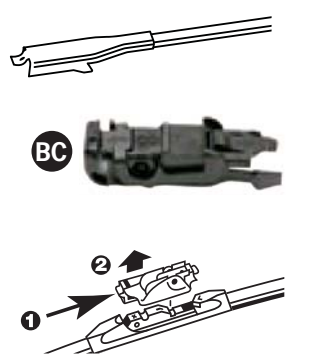
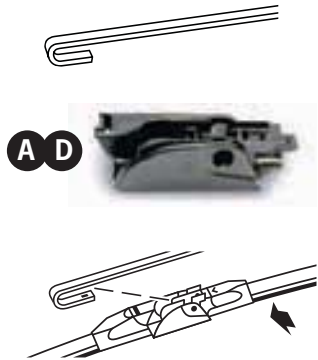

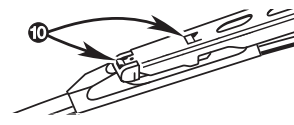
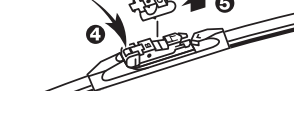
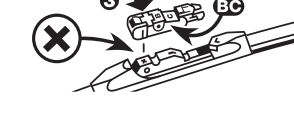
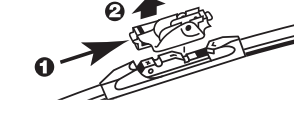
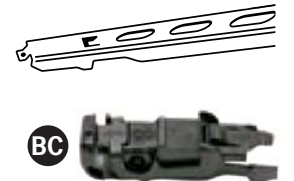
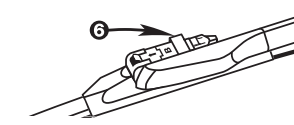
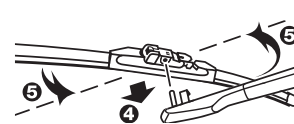
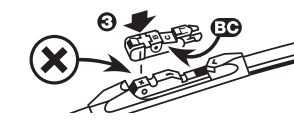
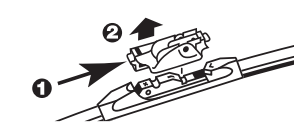
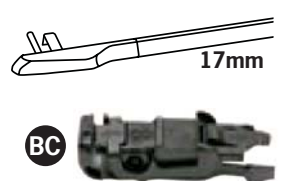
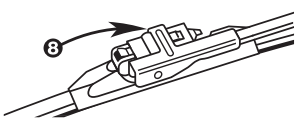
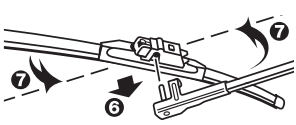
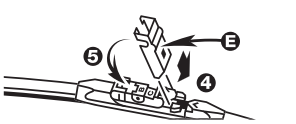
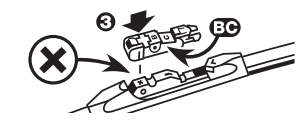
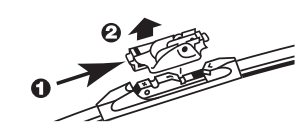
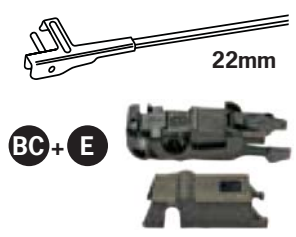
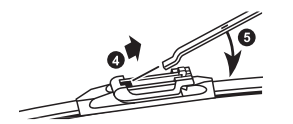
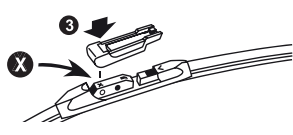
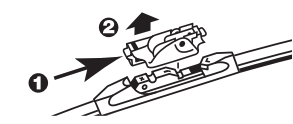

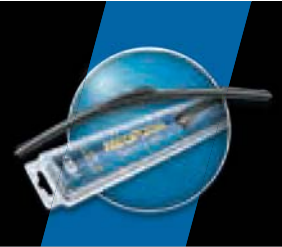

NF**0

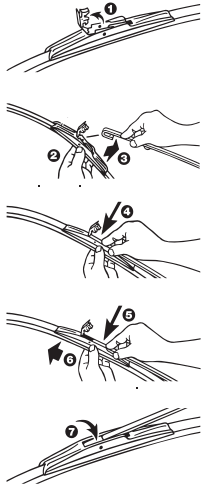

NF**4

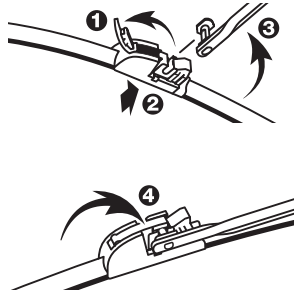

NF**5

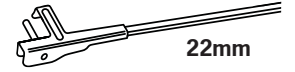
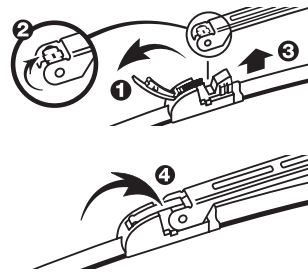

NF**6

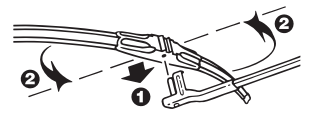

NF**7

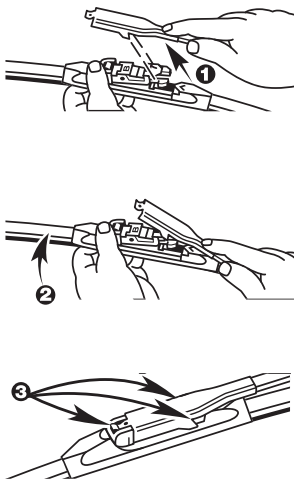

NF**8

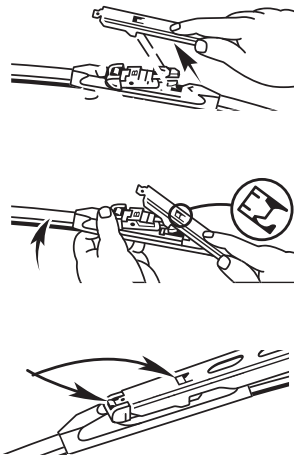

NF**9

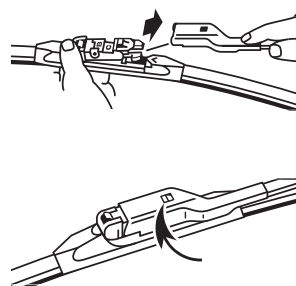

NF**13

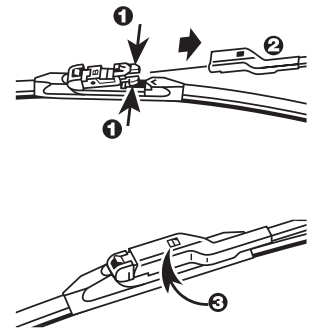

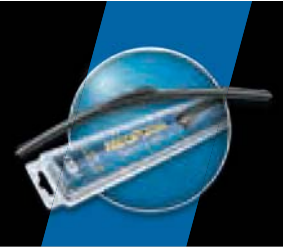

NF**14

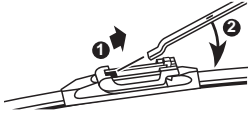

NF**16

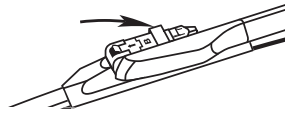
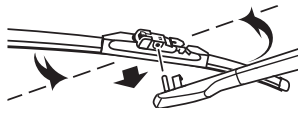



T***0

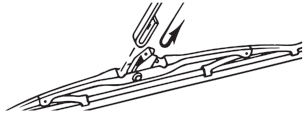

Developed by | Delivered with Scientists | Confidence

Maximum performance multi-clip installation

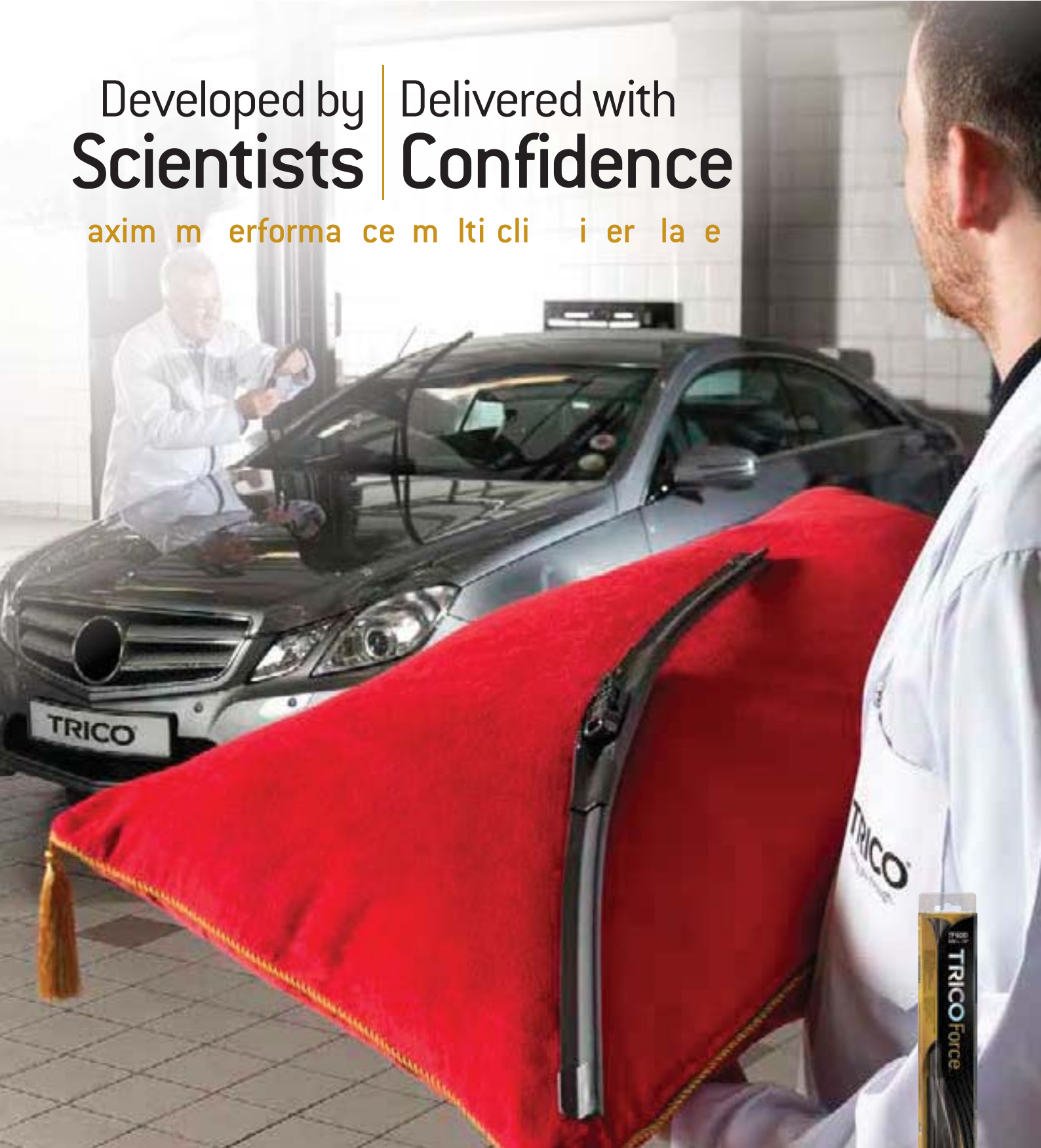

TRICO[®]
seeing you through

trico.eu.com

Introducing TRICO Force: next generation multi-fit wipers.

With a robust design & deep aerodynamic spoiler to combat wind & rain at speeds in excess of 130mph, your customers can benefit from flawless wiper blade performance under the harshest weather conditions. And with just 20 references giving 96% vehicle coverage, you benefit from great vehicle coverage without a vast stock requirement.



TRICO®

seeing you through

www.trico.eu.com



TRICO Ltd, Skewfields, Pontypool, Torfaen, Wales NP4 0XZ UK

T: +44 (0)1495 767700

F: +44 (0)1495 765247

E: sales@trico.eu.com